

Amphenol® Cylindrical Connectors for Printed Circuit Board Applications

12-170-2

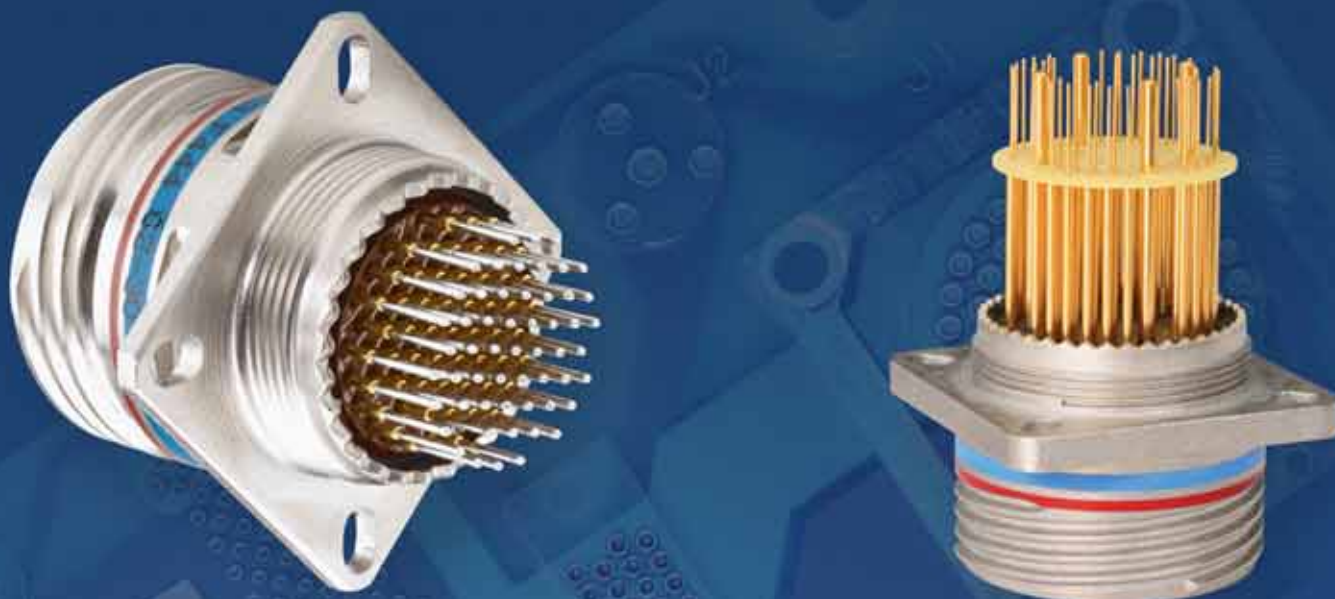

Proven & reliable cylindrical connector solutions for PC board attachment: MIL-DTL-38999, MIL-C-26482 and MIL-5015, with a wide range of contact arrangements and options



Amphenol



This catalog has been specifically designed to assist in the critical process of selecting the right cylindrical connector for a printed circuit board application.

Contact arrangements have been carefully selected to guide designers to the most commonly available and widely used insert patterns.

Pin-out location illustrations of these contact insert patterns are shown first, followed by connector shell drawings in three series:

MIL-DTL-38999, MIL-C-26482, MIL-5015.

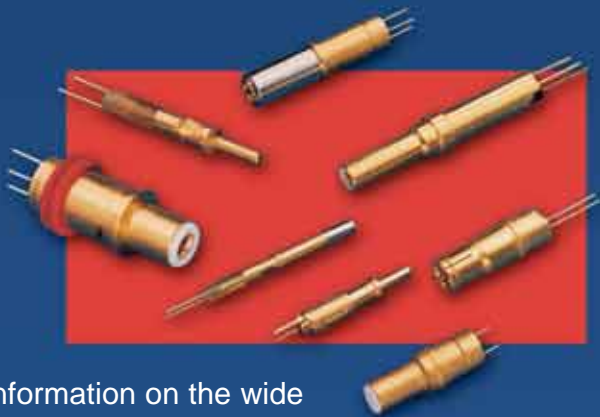
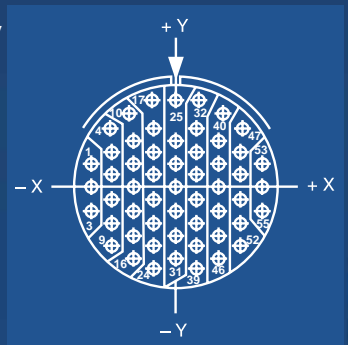

For more information on the wide variety of PC tail contacts that are offered by Amphenol, see catalog 12-130, High Frequency Contacts, which also includes coax, twinax, triax and quadax shielded contacts.



Amphenol has earned the reputation as the leader in the military electrical connection arena. Amphenol's interconnects meet almost any aerospace and ground vehicle design need as well as many industrial needs.

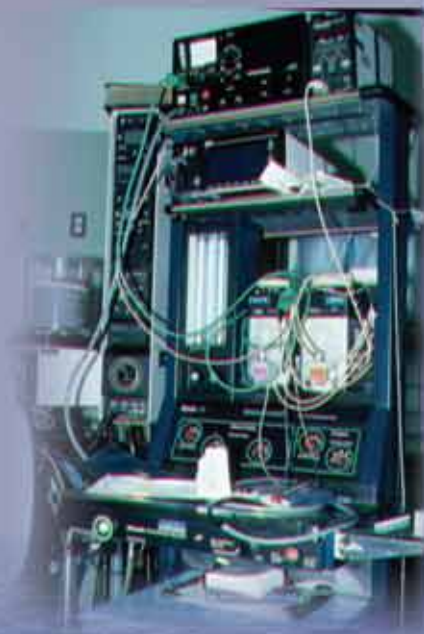

Table of Contents

Amphenol® Cylindrical Connectors for Printed Circuit Board Applications

Page

Introduction	1
Guide to Selecting a PCB Cylindrical Connector	2, 3
Insert Availability	4
Insert Arrangement Drawings	5-24
Alternate Positioning	25-26
MIL-DTL-38999, Series I (LJT) Shell Styles	27-31
MIL-DTL-38999, Series II (JT) Shell Styles	32-34
MIL-DTL-38999, Series III (Tri-Start) Shell Styles	35-39
Stand-off Adapter for use with MIL-DTL-38999 PCB Connectors	40
MIL-C-26482, Series 1 (PT) Shell Styles	41, 42
MIL-5015 (MS3102) Shell Style	43
Universal Header Assemblies for use with Flex print or PCB Connectors	44, 45
Additional Products – Rectangular, for PCB Application ...	46-48
Amphenol Sales Office and Distributor Listing	

If more information is needed concerning the products in this publication, or if you have any special application needs, please contact your nearest Amphenol sales office or Amphenol Corporation at the following address:

Amphenol Corporation
Amphenol Aerospace
40-60 Delaware Ave., Sidney, NY 13838-1395
Phone: 800-678-0141 or 607-563-5011
Fax: 607-563-5157

See this catalog and the majority of catalogs of Amphenol Aerospace and Amphenol Industrial Interconnection Products at:

www.amphenol-aerospace.com

Amphenol operates quality systems that are certified to ISO9001:2000 by third party registrars.



Amphenol[®] Cylindrical Connectors for Printed Circuit Board Applications

Amphenol provides three popular connector series with PC tail contacts. The following key points give a quick overview of these series. For more detail, there are series catalogs available as listed below*. Go to www.amphenol-aerospace.com to view and download these catalogs. There is a guide to selecting a cylindrical connector with printed circuit board contacts on the following page to assist you further.

MIL-DTL-38999 CONNECTORS, METAL & COMPOSITE

- Lightweight, compact, high density and high reliability cylindrical
- Operating voltage to 900 VAC (RMS) at sea level
- Environmentally resistant
- Solder or crimp rear release contacts in mating plug
- Series I (LJT) - Bayonet coupling
 - Scoop-proof (recessed pins) offers maximum contact protection
- Series II (JT) - Bayonet coupling
 - For applications requiring maximum weight/space savings and reliability
- Series III (Tri-Start) - Threaded, quick coupling in one complete turn
 - Designed for general duty as well as severe environmental applications
 - Superior EMI shielding with grounding fingers and metal-to-metal mating
 - Filter/Transient protection versions available
 - Scoop-proof contact protection
 - Stainless steel firewall versions, and composite versions



38999 Series III Box Mount Connector with PC Tails



Special 38999 Connector with Stand-off Shell and PC Tails



38999 Series III Connector with a Special Configuration Composite Shell and PC Tails

MIL-C-26482 CONNECTORS

- Medium size, widely used cylindrical
 - Operating voltage to 1,000 VAC (RMS) at sea level
 - Series 1 (PT) - Bayonet coupling - most commonly used in PCB applications
 - Environmentally resistant
 - Solder or crimp front and rear release contacts in mating plug
- Black/green zinc alloy plating (cadmium-free) available



26482 Series 1 Jam Nut Connector with PC Tails



5015 Box Mount Connector with PC Tails

MIL-5015 CONNECTORS

- Medium-heavy weight, time-tested cylindrical
- Operating voltage to 1,500 VAC (RMS) at sea level
- Environmentally resistant or general duty
- Threaded coupling
- Solder or crimp rear insertion contacts in mating plug
- Black/green zinc alloy plating (cadmium-free) available

Also provided in this catalog are several additional product options for the designer of PCB board applications. For example: Amphenol's flex assemblies provide solutions for attachment to PCB boards where a self-locking terminal pad is needed or in tight-fitting space requirements. Connectors with compliant pin contacts are available, and pc tails within shielded coax, twinax and triax contacts are available. At the end of the catalog, see a brief description of Amphenol PCB rectangular connectors, backplane assemblies, terminal blocks and wiring interface modules.



Flex Termination with MIL-C-26482 Special Connector

* Request Catalog 12-090 for MIL-DTL-38999 Series I, II
 Request Catalog 12-092 for MIL-DTL-38999 Series III
 Request Catalog 12-070 for MIL-C-26482, Series 1, 2
 Request Catalog 12-071 for Matrix MIL-C-26482 Series 2
 Request Catalog 12-020 for MIL-5015

Go to www.amphenol-aerospace.com for catalogs online.

Note: MIL-DTL-38999 supersedes MIL-C-38999.

Guide to Selecting a PCB Cylindrical Connector

The connector selection process is one of the most important engineering decisions to be made in any electronic application. Amphenol has created this catalog specifically to provide the necessary information to select, layout and design both the appropriate Amphenol® cylindrical connector with PCB contacts and the connector footprint (contact locations) on the printed circuit board. The guide that follows is for application of cylindrical connectors on rigid printed circuit boards and also applies if a flex print assembly or other optional is being used.

Engineers working on those PCB or flex print applications requiring rectangular connectors are encouraged to refer to page 46-48 and ask for Amphenol Rectangular Product catalogs.

How To Select a Cylindrical Connector for a PCB Application

The data provided in this catalog is based on three cylindrical connector series: MIL-DTL-38999 Series I, II and III, MIL-C-26482 Series 1, and MIL-C-5015. See page 1 for electrical and environmental features and differences of these three series. The “hot” side of the application determines the choice of pin or socket genders of the contacts.

How to Measure the PCB Tail Length

The tail length of the PCB is the portion of the contact that extends beyond the rear of the shell. This length will vary in relationship to the mounting flange, depending on the series of connector selected. Standard lengths are shown on the connector shell style drawings in this catalog. These shell style drawing pages also provide how to order part numbering for standard PCB cylindrical connectors.

When computing the desired tail length, it is important to take into consideration the following factors:

- The connector series and shell style.
- The mounting style of the receptacle; jam nut (D hole) or panel mount (four holes). This can affect the overall length of the tail.
- The extension of the tail beyond the opposite side of the board or the flex.
- The space required to adequately clean flux from between the board or flex and the rear of the connector shell. Connectors that are mounted flush against the board may trap soldering flux which could lead to corrosion of the solder joints.

Would Alignment Discs, Headers or Special Stand-off Shells be Beneficial?

Any mechanical methods needed to stabilize the board or flex to the connector and/or the panel. The PCB tails shown in this catalog are of one diameter. Stepped tails or PCB tails with an increased diameter on a designated portion may be required for certain applications.

Alignment discs are available which provide ease of alignment of pins to boards, protection during shipment and optimized electrical circuit separation. Header assemblies (see pages 44 & 45) are available which provide time and cost saving potentials. Standoffs may be required for certain applications. Amphenol has developed a new stand-off adapter (see page 40) which may eliminate the need for special stand-off shell designs. Connectors with clinch nuts can be provided. Please call Amphenol to discuss any optional designs or any special requirements.

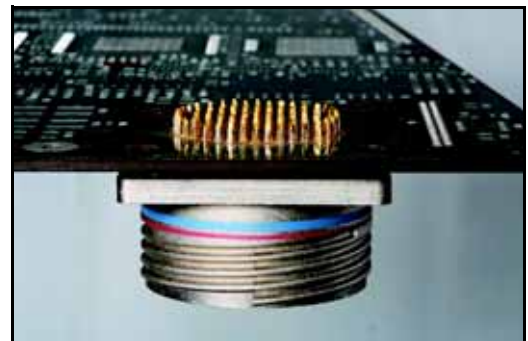
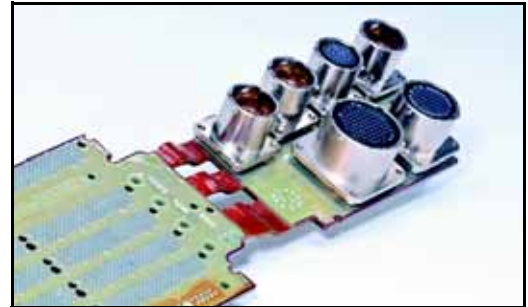

Stand-off Adapter on a Jam Nut Receptacle.



Special Design with Longer PC Tails in a 38999 Composite Shell Connector. Also shows an Alignment Disc.



Universal Header Assemblies are available for Flex Print/PC Board Mounting. Beneficial especially when electrical testing of the connector requires it to be removed and reattached.

Guide to Selecting a PCB Cylindrical Connector, cont.

What Determines the Diameter of the PCB Tail?

The outside diameter of the PCB tail is determined by the inside diameter of the plated through-hole on the board or flex print. The standard or most popular diameters are shown in the chart on the next page and are called out in the connector illustrations in this catalog (Pgs. 26-37).

Standard diameters of PCB tails

Connector Series	Size 16 Contact	Size 20 Contact	Size 22D Contact
MIL-DTL-38999	.062 ±.001	.019 ±.001	.019 ±.001
MIL-C-26482	.030 ±.001	.030 ±.001	Not available
MIL-5015	.030 ±.001	Not available	Not available

For availability of other contact diameters, consult Amphenol, Sidney NY.

Should PCB Tails be Gold Plated or Pre-tinned?

The standard PCB tails for MIL-DTL-38999 and MIL-C-26482 receptacles have gold plating, .00050 inches over nickel. PCB tails for MIL-C-5015 receptacles are plated with silver, .00010 inches over copper. Amphenol can substitute a pre-tinned version of these tails to facilitate the termination process. This pre-tinning is a 60/40 lead-tin alloy. Call Amphenol for further information on pre-tinning and any other plating of contacts not covered in this catalog.

Would Flex Assemblies be Necessary or Beneficial for the Application?

Flex print can radically simplify the assembly of a connector to a system, as well as eliminate wiring errors. Amphenol offers connector flex assemblies through ACT, Advanced Circuit Technologies division. Features and benefits of using flex technology include:

- Available for MIL-DTL-38999 (including filter EMI/EMP types), MIL-5015 and MIL-C-26482 cylindrical connectors
- Sculptures® Flexible Circuits with built-in terminations
- Eliminates failures associated with crimped or solder-on contacts
- Geometrically fit tight space requirements and create a self-locking terminal pad

Should Other PC Tail Contact Types be Considered?

Press-Fit Connectors with compliant pins are available which engage the plated through-holes in the board without the need for soldering. This optional contact style offers the following benefits

- Easy board repairability
- Improved board processing time
- Excellent temperature performance
- Ideal for low-lead applications

For more information on Press-Fit connectors with compliant pins refer to Amphenol data sheet #188.

Special Quadrax contacts have been designed with PC tails. Coax, twinax and triax contacts can also have PC tails. Refer to Amphenol catalog 12-130. Go online at www.amphenol-aerospace.com or consult Amphenol Aerospace for further information.

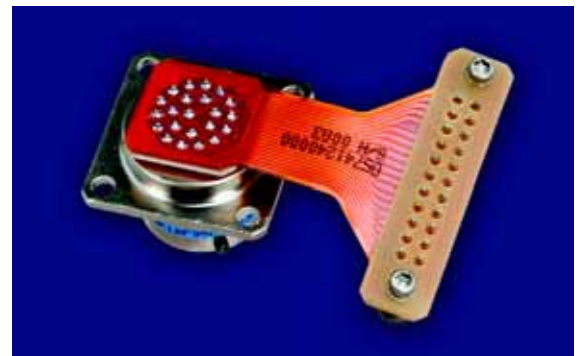

Flex Termination for Attachment to PC Boards



Compliant Pin Contacts in a Bayonet 38999 Catalog



Quadrax PC Tail Contacts Combined with Standard PC Tail Contacts



Quadrax Contacts with PC Tails in a 38999 Connector with Special Stand-off Shell

Cylindrical Connectors with PCB contacts insert availability

The following table lists the most commonly used insert arrangements for printed circuit board application of MIL-DTL-38999, MIL-C-26482 and MIL-C-5015 cylindrical connectors. This represents the most readily available patterns within these series. See illustrations of these selected patterns on the following pages. If you require other arrangements than what are shown here, consult Amphenol for further availability.

MIL-DTL-38999			MIL-C-26482	MIL-5015	Service Rating	Total Contacts	Contact Size*		
JT Series II	LJT Series I	Tri-Start Series III					22D	20	16
8-3	9-3		8-3		M/I	3		3	
8-35	9-35	9-35			M	6	6		
8-98	9-98	9-98	8-98		I	3		3	
				10SL-3	A	3			3
10-5	11-5	11-5	10-5		I	5		5	
	11-6		10-6		I	6		6	
10-35	11-35	11-35			M	13	13		
12-3	13-3		12-3		II	3			3
			12-10		I	10		10	
12-35	13-35	13-35			M	22	22		
				14S-6	Inst.	6			6
14-18	15-18	15-18	14-18		I	18		18	
14-19	15-19	15-19	14-19		I	19		19	
14-35	15-35	15-35			M	37	37		
				16S-1	A	7			7
16-26	17-26	17-26	16-26		I	26		26	
16-35	17-35	17-35			M	55	55		
				18-1	A/Inst.	10			10
18-11	19-11	19-11	18-11		II	11			11
18-32	19-32	19-32	18-32		I	32		32	
18-35	19-35	19-35			M	66	66		
				20-11	Inst.	13			13
20-27	21-27		20-27		I	27		27	
20-35	21-35	21-35			M	79	79		
20-41	21-41	21-41	20-41		I	41		41	
				22-14	A	19			19
22-35	23-35	23-35			M	100	100		
22-55	23-55	23-55	22-55		I	55		55	
				24-5	A	16			16
				24-28	Inst.	24			24
24-31			24-31		I	31			31
24-35	25-35	25-35			M	128	128		
24-61	25-61	25-61	24-61		I	61		61	
				28-15	A	35			35

* For information on size 12 PC tail contacts consult Amphenol Aerospace.

Cylindrical Connectors with PCB contacts insert arrangements, cont.

Insert Arrangement #8-3 / 9-3

Connector Type:	JT MIL-DTL-38999 Series II	LJT MIL-DTL-38999 Series I	Tri-Start MIL-DTL-38999 Series III	MIL-C-26482 Series 1 & 2	MIL-5015
Insert Designation:	8-3	9-3	NA	8-3	NA

Contact Locations Front face of pin insert shown	Number of Contacts	Contact Size	Service Rating*
	3	20	M/I

*Service Rating: M for MIL-DTL-38999
I for MIL-C-26482

Insert Arrangement #8-35 / 9-35

Connector Type:	JT MIL-DTL-38999 Series II	LJT MIL-DTL-38999 Series I	Tri-Start MIL-DTL-38999 Series III	MIL-C-26482 Series 1 & 2	MIL-5015
Insert Designation:	8-35	9-35	9-35	NA	NA

Contact Locations Front face of pin insert shown	Number of Contacts	Contact Size	Service Rating
	6	22D	M

All dimensions for reference only. For alternate rotations see pages 25 & 26.
 Note: Shown in this catalog are the most common insert patterns for PCB applications.
 For availability of other arrangements, consult Amphenol Corp., Sidney, NY.

Cylindrical Connectors with PCB contacts insert arrangements, cont.

Insert Arrangement #8-98 / 9-98

Connector Type:	JT MIL-DTL-38999 Series II	LJT MIL-DTL-38999 Series I	Tri-Start MIL-DTL-38999 Series III	MIL-C-26482 Series 1 & 2	MIL-5015
Insert Designation:	8-98	9-98	9-98	8-98	NA

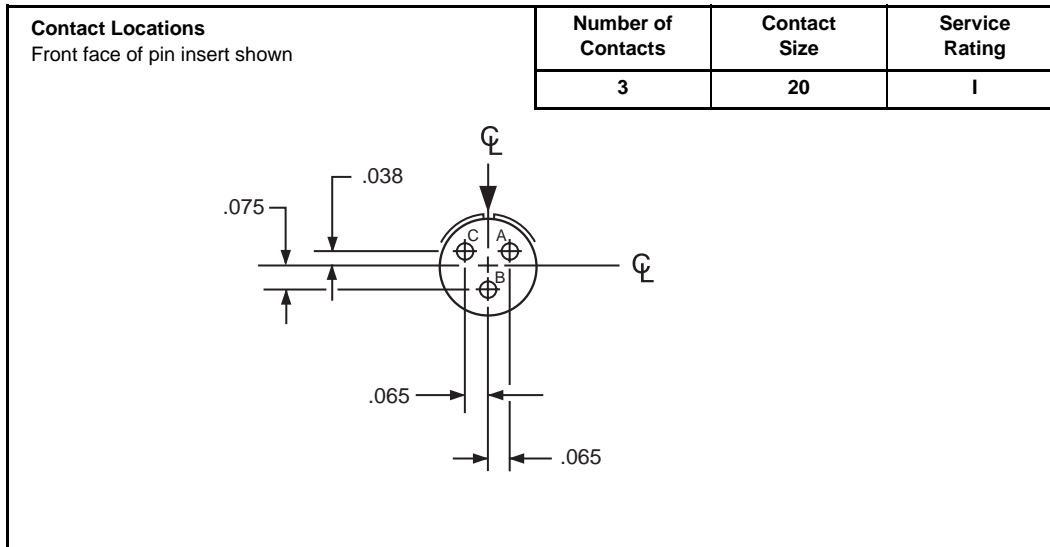

Insert Arrangement #10SL-3

Connector Type:	JT MIL-DTL-38999 Series II	LJT MIL-DTL-38999 Series I	Tri-Start MIL-DTL-38999 Series III	MIL-C-26482 Series 1 & 2	MIL-5015
Insert Designation:	NA	NA	NA	NA	10SL-3

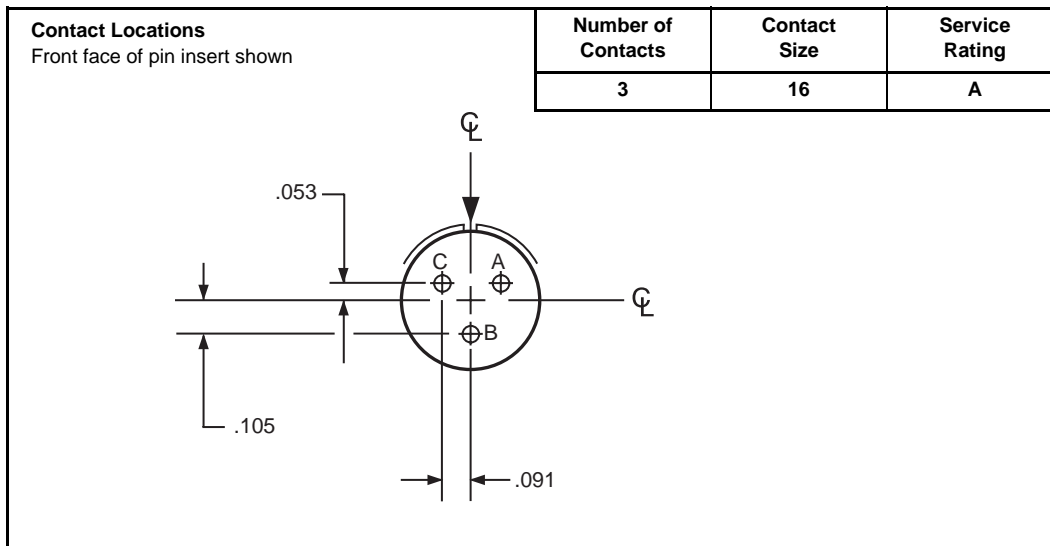

All dimensions for reference only. For alternate rotations see pages 25 & 26.
 Note: Shown in this catalog are the most common insert patterns for PCB applications.
 For availability of other arrangements, consult Amphenol Corp., Sidney, NY.

Cylindrical Connectors with PCB contacts insert arrangements, cont.

Insert Arrangement #10-5 / 11-5

Connector Type:	JT MIL-DTL-38999 Series II	LJT MIL-DTL-38999 Series I	Tri-Start MIL-DTL-38999 Series III	MIL-C-26482 Series 1 & 2	MIL-5015
Insert Designation:	10-5	11-5	11-5	10-5	NA

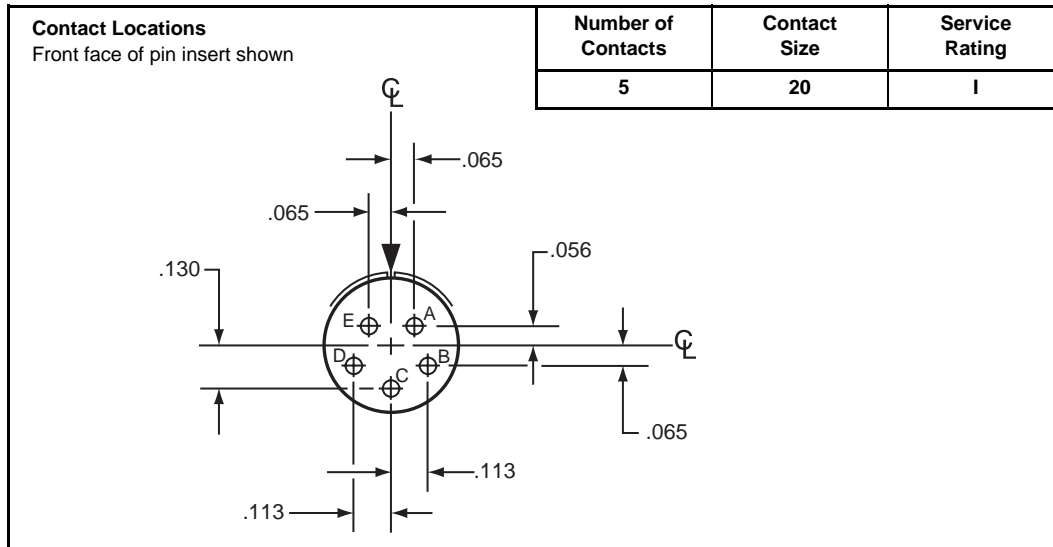

Insert Arrangement #10-6 / 11-6

Connector Type:	JT MIL-DTL-38999 Series II	LJT MIL-DTL-38999 Series I	Tri-Start MIL-DTL-38999 Series III	MIL-C-26482 Series 1 & 2	MIL-5015
Insert Designation:	NA	11-6	NA	10-6	NA

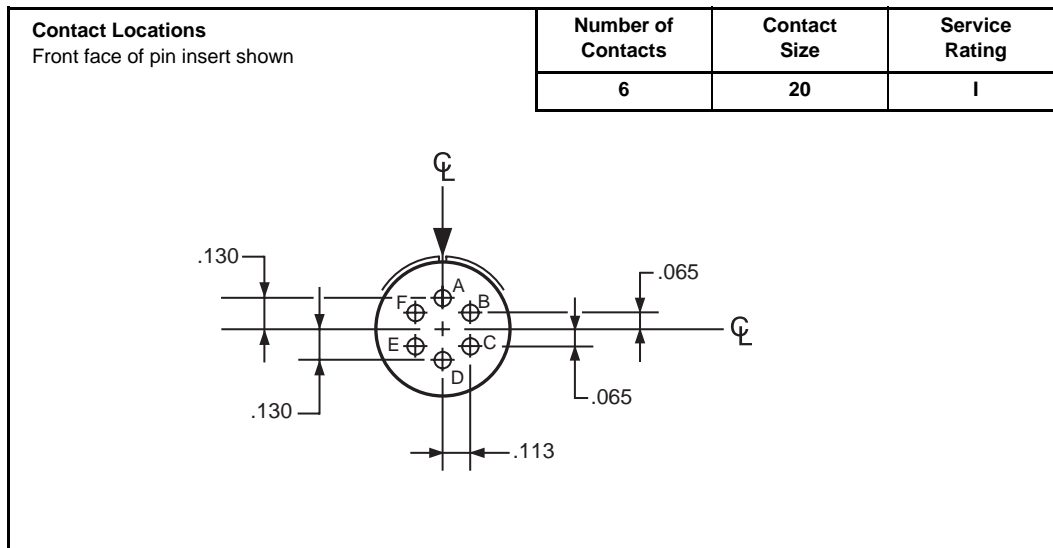

All dimensions for reference only. For alternate rotations see pages 25 & 26.
 Note: Shown in this catalog are the most common insert patterns for PCB applications.
 For availability of other arrangements, consult Amphenol Corp., Sidney, NY.

Cylindrical Connectors with PCB contacts insert arrangements, cont.

Insert Arrangement #10-35 / 11-35

Connector Type:	JT MIL-DTL-38999 Series II	LJT MIL-DTL-38999 Series I	Tri-Start MIL-DTL-38999 Series III	MIL-C-26482 Series 1 & 2	MIL-5015
Insert Designation:	10-35	11-35	11-35	NA	NA

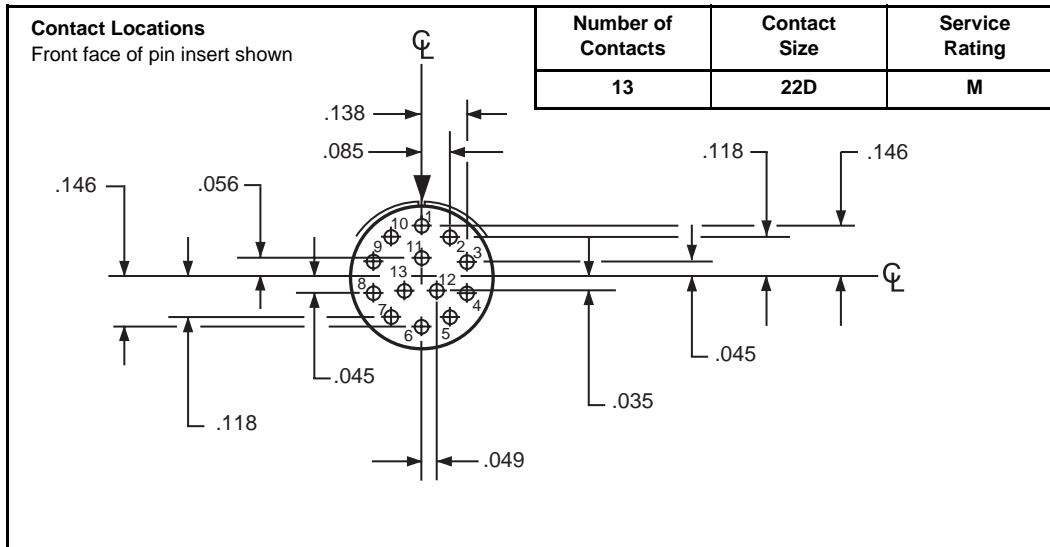

Insert Arrangement #12-3 / 13-3

Connector Type:	JT MIL-DTL-38999 Series II	LJT MIL-DTL-38999 Series I	Tri-Start MIL-DTL-38999 Series III	MIL-C-26482 Series 1 & 2	MIL-5015
Insert Designation:	12-3	13-3	NA	12-3	NA

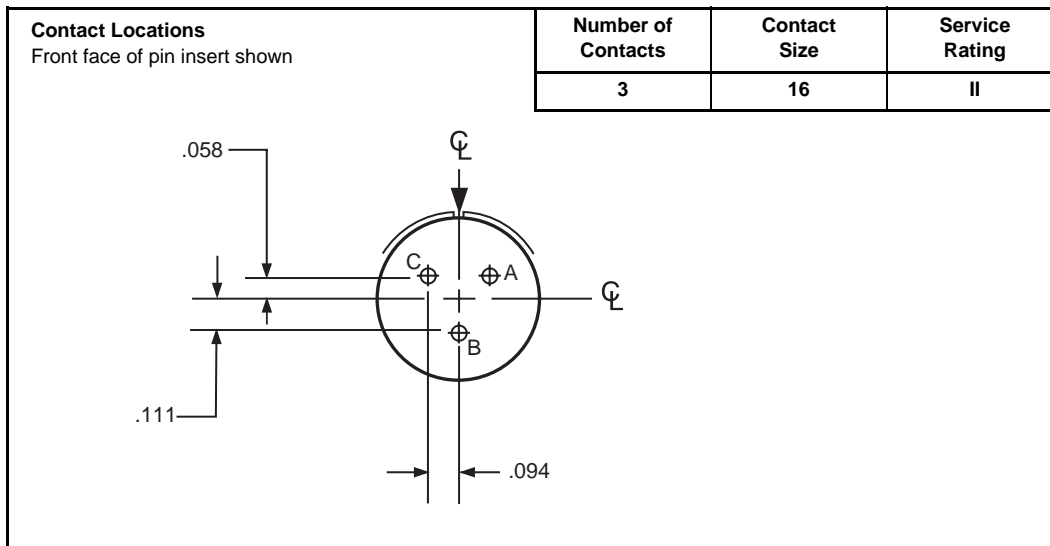

All dimensions for reference only. For alternate rotations see pages 25 & 26.
 Note: Shown in this catalog are the most common insert patterns for PCB applications.
 For availability of other arrangements, consult Amphenol Corp., Sidney, NY.

Cylindrical Connectors with PCB contacts insert arrangements, cont.

Insert Arrangement #12-10

Connector Type:	JT MIL-DTL-38999 Series II	LJT MIL-DTL-38999 Series I	Tri-Start MIL-DTL-38999 Series III	MIL-C-26482 Series 1 & 2	MIL-5015
Insert Designation:	NA	NA	NA	12-10	NA

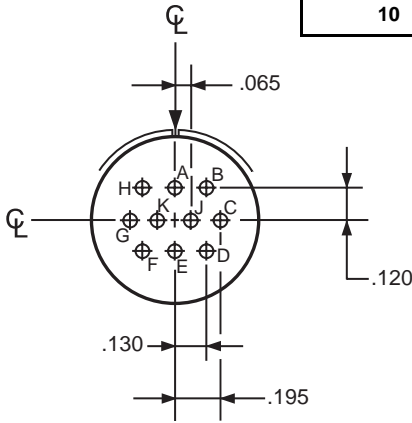
Contact Locations Front face of pin insert shown	Number of Contacts	Contact Size	Service Rating
	10	20	I

Insert Arrangement #12-35 / 13-35

Connector Type:	JT MIL-DTL-38999 Series II	LJT MIL-DTL-38999 Series I	Tri-Start MIL-DTL-38999 Series III	MIL-C-26482 Series 1 & 2	MIL-5015
Insert Designation:	12-35	13-35	13-35	NA	NA

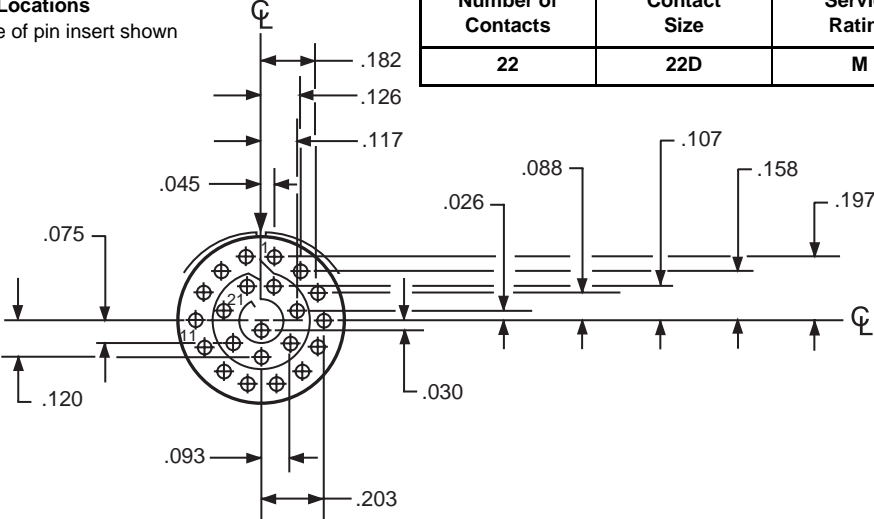
Contact Locations Front face of pin insert shown	Number of Contacts	Contact Size	Service Rating
	22	22D	M

All dimensions for reference only. For alternate rotations see pages 25 & 26.
 Note: Shown in this catalog are the most common insert patterns for PCB applications.
 For availability of other arrangements, consult Amphenol Corp., Sidney, NY.

Cylindrical Connectors with PCB contacts insert arrangements, cont.

Insert Arrangement #14S-6

Connector Type:	JT MIL-DTL-38999 Series II	LJT MIL-DTL-38999 Series I	Tri-Start MIL-DTL-38999 Series III	MIL-C-26482 Series 1 & 2	MIL-5015
	NA	NA	NA	NA	14S-6

Contact Locations Front face of pin insert shown	Number of Contacts	Contact Size	Service Rating
	6	16	Inst.

Insert Arrangement #14-18 / 15-18

Connector Type:	JT MIL-DTL-38999 Series II	LJT MIL-DTL-38999 Series I	Tri-Start MIL-DTL-38999 Series III	MIL-C-26482 Series 1 & 2	MIL-5015
	14-18	15-18	15-18	14-18	NA

Contact Locations Front face of pin insert shown	Number of Contacts	Contact Size	Service Rating
	18	20	I

All dimensions for reference only. For alternate rotations see pages 25 & 26
 Note: Shown in this catalog are the most common insert patterns for PCB applications.
 For availability of other arrangements, consult Amphenol Corp., Sidney, NY.

Cylindrical Connectors with PCB contacts insert arrangements, cont.

Insert Arrangement #14-19 / 15-19

Connector Type:	JT MIL-DTL-38999 Series II	LJT MIL-DTL-38999 Series I	Tri-Start MIL-DTL-38999 Series III	MIL-C-26482 Series 1 & 2	MIL-5015
Insert Designation:	14-19	15-19	15-19	14-19	NA

Number of Contacts	Contact Size	Service Rating
19	20	I

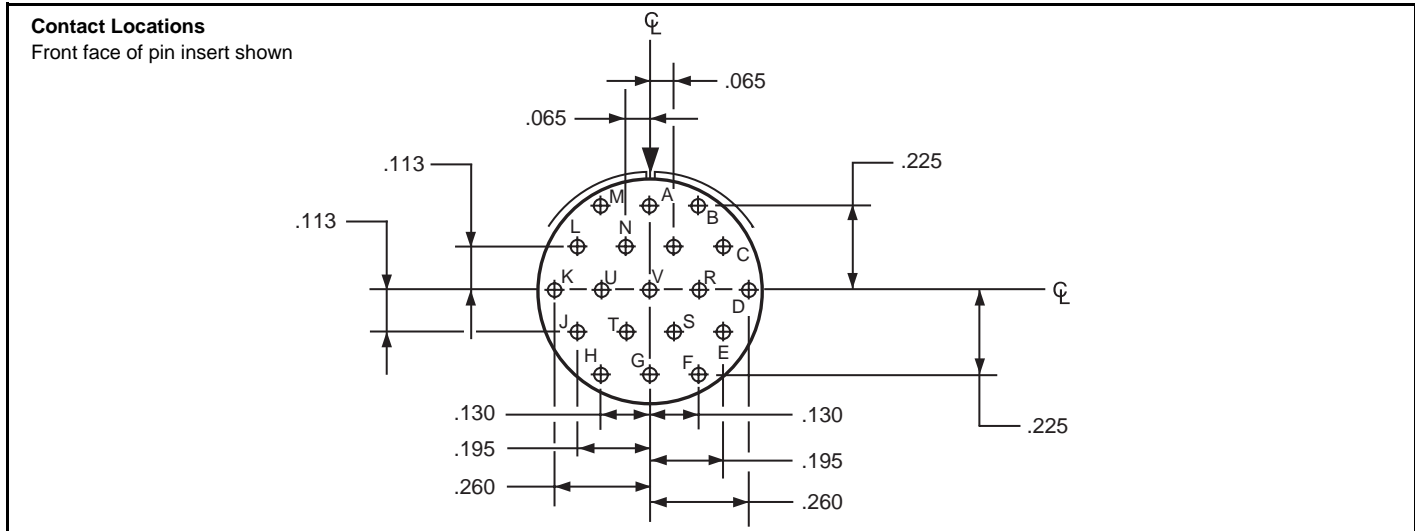

Insert Arrangement #14-35 / 15-35

Connector Type:	JT MIL-DTL-38999 Series II	LJT MIL-DTL-38999 Series I	Tri-Start MIL-DTL-38999 Series III	MIL-C-26482 Series 1 & 2	MIL-5015
Insert Designation:	14-35	15-35	15-35	NA	NA

Number of Contacts	Contact Size	Service Rating
37	22D	M

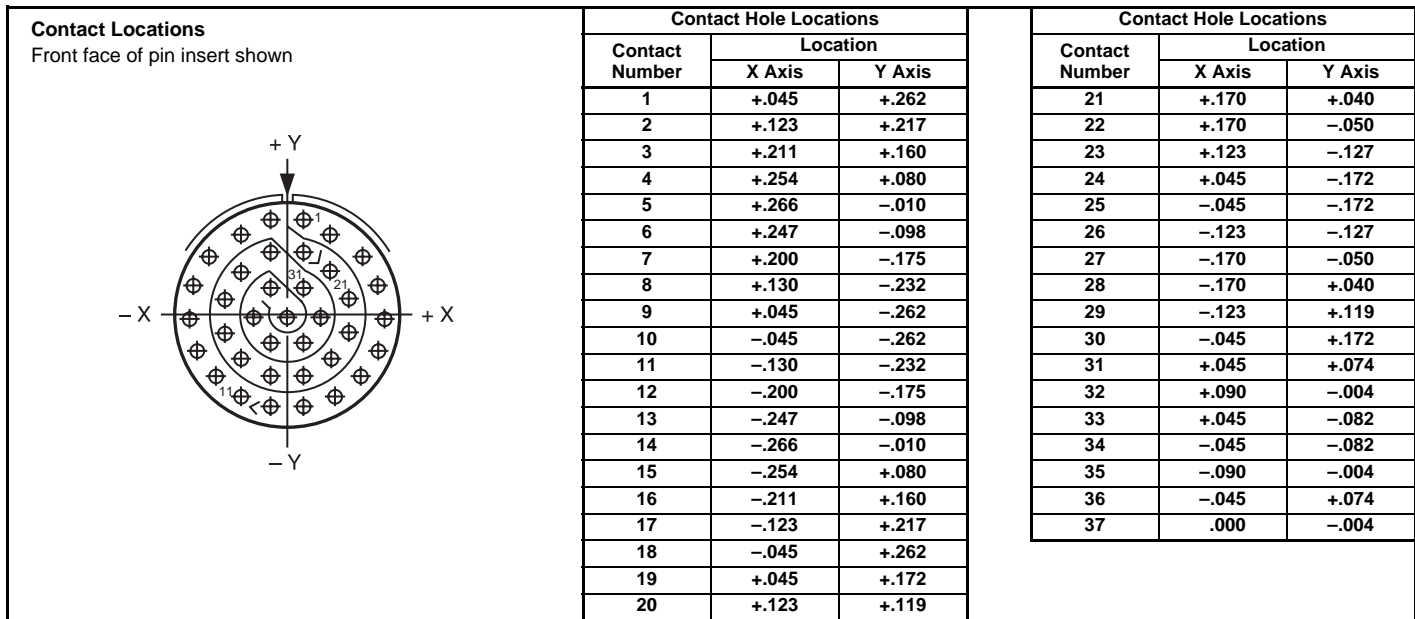

All dimensions for reference only. For alternate rotations see pages 25 & 26.
 Note: Shown in this catalog are the most common insert patterns for PCB applications. For availability of other arrangements, consult Amphenol Corp., Sidney, NY.

Cylindrical Connectors with PCB contacts insert arrangements, cont.

Insert Arrangement #16S-1

Connector Type:	JT MIL-DTL-38999 Series II	LJT MIL-DTL-38999 Series I	Tri-Start MIL-DTL-38999 Series III	MIL-C-26482 Series 1 & 2	MIL-5015
Insert Designation:	NA	NA	NA	NA	16S-1

Number of Contacts	Contact Size	Service Rating
7	16	A

Contact Locations
Front face of pin insert shown

Insert Arrangement #16-26 / 17-26

Connector Type:	JT MIL-DTL-38999 Series II	LJT MIL-DTL-38999 Series I	Tri-Start MIL-DTL-38999 Series III	MIL-C-26482 Series 1 & 2	MIL-5015
Insert Designation:	NA	17-26	17-26	16-26	NA

Number of Contacts	Contact Size	Service Rating
26	20	I

Contact Locations
Front face of pin insert shown

Contact Hole Locations		
Contact Number	Location	
	X Axis	Y Axis
A	.000	+.321
B	+.131	+.293
C	+.239	+.214
D	+.305	+.099
E	+.319	-.034
F	+.278	-.161
G	+.189	-.260
H	+.067	-.314
J	-.067	-.314
K	-.189	-.260
L	-.278	-.161
M	-.319	-.034
N	-.305	+.099
P	-.239	+.214

Contact Hole Locations		
Contact Number	Location	
	X Axis	Y Axis
R	-.131	+.293
S	-.070	+.177
T	+.070	+.177
U	+.175	+.094
V	+.178	-.036
W	+.119	-.151
X	.000	-.203
Y	-.119	-.151
Z	-.178	-.036
a	-.175	+.094
b	.000	+.065
c	.000	-.065

All dimensions for reference only. For alternate rotations see pages 25 & 26.

Note: Shown in this catalog are the most common insert patterns for PCB applications. For availability of other arrangements, consult Amphenol Corp., Sidney, NY.

Cylindrical Connectors with PCB contacts insert arrangements, cont.

Insert Arrangement #16-35 / 17-35

Connector Type:	JT MIL-DTL-38999 Series II	LJT MIL-DTL-38999 Series I	Tri-Start MIL-DTL-38999 Series III	MIL-C-26482 Series 1 & 2	MIL-5015
Insert Designation:	16-35	17-35	17-35	NA	NA

Number of Contacts	Contact Size	Service Rating
55	22D	M

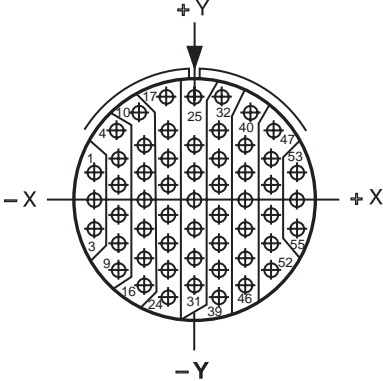
Contact Locations Front face of pin insert shown	Contact Hole Locations			Contact Hole Locations		
	Contact Number	Location		Contact Number	Location	
	X Axis	Y Axis	X Axis	Y Axis		
	1	-.312	+.086	32	+.089	+.316
	2	-.312	-.004	33	+.078	+.221
	3	-.312	-.094	34	+.078	+.131
	4	-.242	+.221	35	+.078	+.041
	5	-.234	+.131	36	+.078	-.049
	6	-.234	+.041	37	+.078	-.139
	7	-.234	-.049	38	+.078	-.229
	8	-.234	-.139	39	+.078	-.319
	9	-.234	-.229	40	+.172	+.279
	10	-.172	+.279	41	+.156	+.176
	11	-.156	+.176	42	+.156	+.086
	12	-.156	+.086	43	+.156	-.004
	13	-.156	-.004	44	+.156	-.094
	14	-.156	-.094	45	+.156	-.184
	15	-.156	-.184	46	+.156	-.274
	16	-.156	-.274	47	+.242	+.221
	17	-.089	+.316	48	+.234	+.131
	18	-.078	+.221	49	+.234	+.041
	19	-.078	+.131	50	+.234	-.049
	20	-.078	+.041	51	+.234	-.139
	21	-.078	-.049	52	+.234	-.229
	22	-.078	-.139	53	+.312	+.086
	23	-.078	-.229	54	+.312	-.004
	24	-.078	-.319	55	+.312	-.094
	25	.000	+.329			
	26	.000	+.176			
	27	.000	+.086			
	28	.000	-.004			
	29	.000	-.094			
	30	.000	-.184			
	31	.000	-.274			

All dimensions for reference only. For alternate rotations see pages 25 & 26.
 Note: Shown in this catalog are the most common insert patterns for PCB applications.
 For availability of other arrangements, consult Amphenol Corp., Sidney, NY.

Cylindrical Connectors with PCB contacts insert arrangements, cont.

Insert Arrangement #18-1

Connector Type:	JT MIL-DTL-38999 Series II	LJT MIL-DTL-38999 Series I	Tri-Start MIL-DTL-38999 Series III	MIL-C-26482 Series 1 & 2	MIL-5015
Insert Designation:	NA	NA	NA	NA	18-1

Number of Contacts	Contact Size	Service Rating*
10	16	A/Inst.

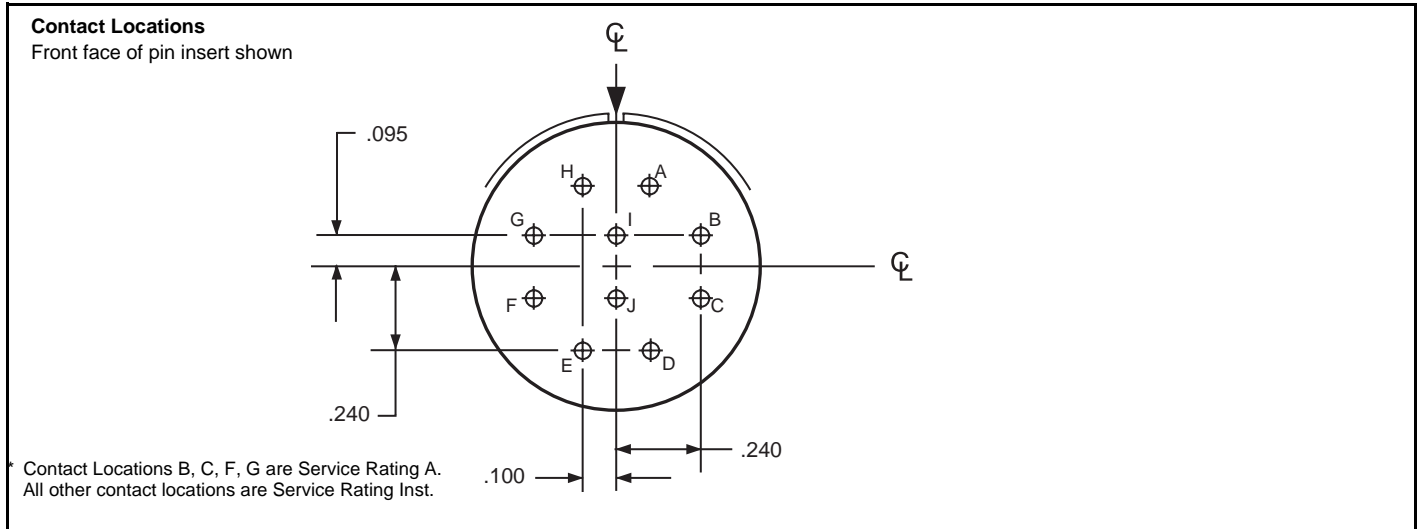

Insert Arrangement #18-11 / 19-11

Connector Type:	JT MIL-DTL-38999 Series II	LJT MIL-DTL-38999 Series I	Tri-Start MIL-DTL-38999 Series III	MIL-C-26482 Series 1 & 2	MIL-5015
Insert Designation:	18-11	19-11	19-11	18-11	NA

Number of Contacts	Contact Size	Service Rating
11	16	II

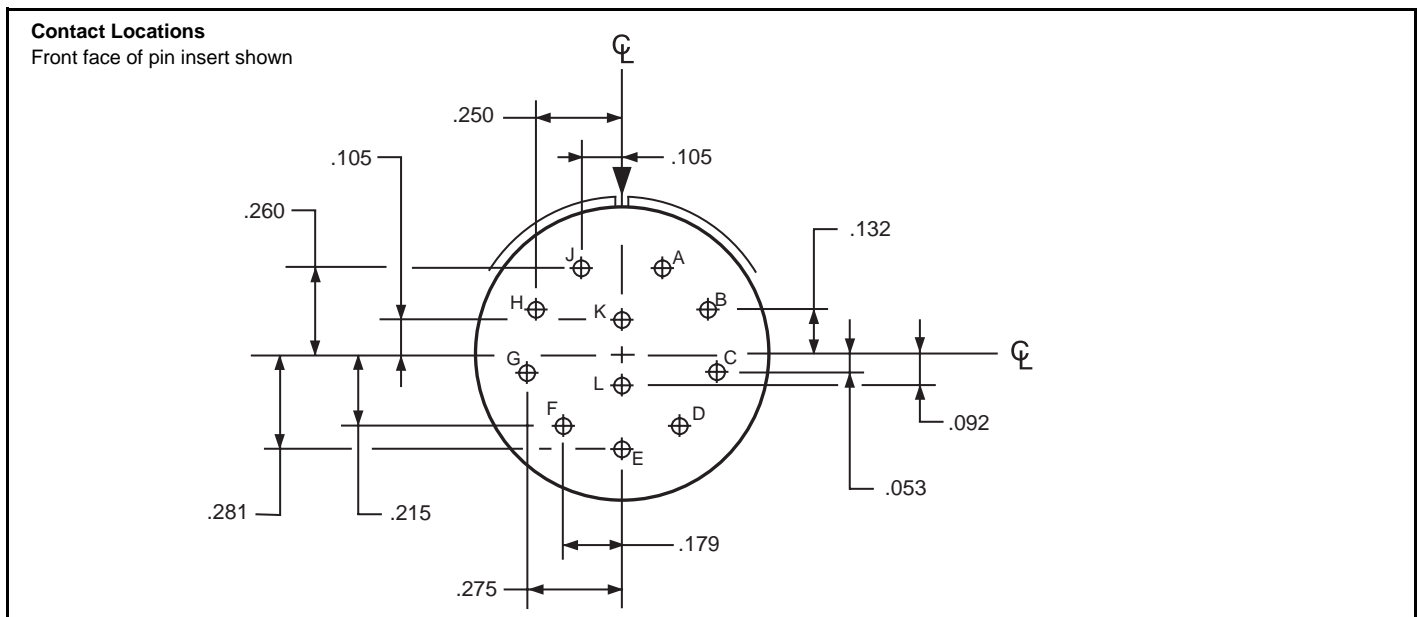

All dimensions for reference only. For alternate rotations see pages 25 & 26.

Note: Shown in this catalog are the most common insert patterns for PCB applications. For availability of other arrangements, consult Amphenol Corp., Sidney, NY.

Cylindrical Connectors with PCB contacts insert arrangements, cont.

Insert Arrangement #18-32 / 19-32

Connector Type:	JT MIL-DTL-38999 Series II	LJT MIL-DTL-38999 Series I	Tri-Start MIL-DTL-38999 Series III	MIL-C-26482 Series 1 & 2	MIL-5015
Insert Designation:	18-32	19-32	19-32	18-32	NA

Number of Contacts	Contact Size	Service Rating
32	20	I

Contact Locations
Front face of pin insert shown

Contact Hole Locations

Contact Letter	Location	
	X Axis	Y Axis
A	+.066	+.353
B	+.189	+.305
C	+.286	+.217
D	+.345	+.098
E	+.357	-.033
F	+.321	-.160
G	+.242	-.265
H	+.130	-.335
J	.000	-.359
K	-.130	-.335
L	-.242	-.265
M	-.321	-.160
N	-.357	-.033
P	-.345	+.098
R	-.286	+.217
S	-.189	+.305
T	-.066	+.353
U	.000	+.230

Contact Hole Locations

Contact Letter	Location	
	X Axis	Y Axis
V	+.124	+.193
W	+.209	+.095
X	+.228	-.033
Y	+.174	-.151
Z	+.065	-.221
a	-.065	-.221
b	-.174	-.151
c	-.228	-.033
d	-.209	+.095
e	-.124	+.193
f	.000	+.096
g	+.096	.000
h	.000	-.096
j	-.096	.000

Insert Arrangement #18-35 / 19-35

Connector Type:	JT MIL-DTL-38999 Series II	LJT MIL-DTL-38999 Series I	Tri-Start MIL-DTL-38999 Series III	MIL-C-26482 Series 1 & 2	MIL-5015
Insert Designation:	18-35	19-35	19-35	NA	NA

Number of Contacts	Contact Size	Service Rating
66	22D	M

Contact Locations
Front face of pin insert shown

All dimensions for reference only. For alternate rotations see pages 25 & 26.
 Note: Shown in this catalog are the most common insert patterns for PCB applications. For availability of other arrangements, consult Amphenol Corp., Sidney, NY.

Cylindrical Connectors with PCB contacts insert arrangements, cont.

Insert Arrangement #20-11

Connector Type:	JT MIL-DTL-38999 Series II	LJT MIL-DTL-38999 Series I	Tri-Start MIL-DTL-38999 Series III	MIL-C-26482 Series 1 & 2	MIL-5015
Insert Designation:	NA	NA	NA	NA	20-11

Number of Contacts	Contact Size	Service Rating
13	16	Inst.

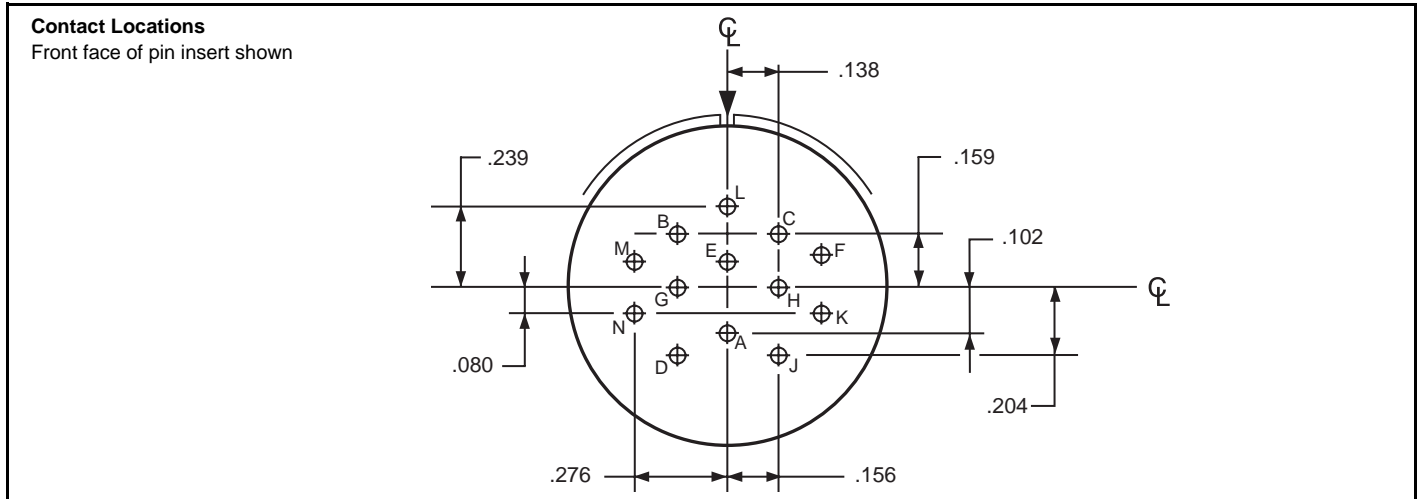

Insert Arrangement #20-27 / 21-27

Connector Type:	JT MIL-DTL-38999 Series II	LJT MIL-DTL-38999 Series I	Tri-Start MIL-DTL-38999 Series III	MIL-C-26482 Series 1 & 2	MIL-5015
Insert Designation:	20-27	21-27	NA	20-27	NA

Number of Contacts	Contact Size	Service Rating
27	20	I

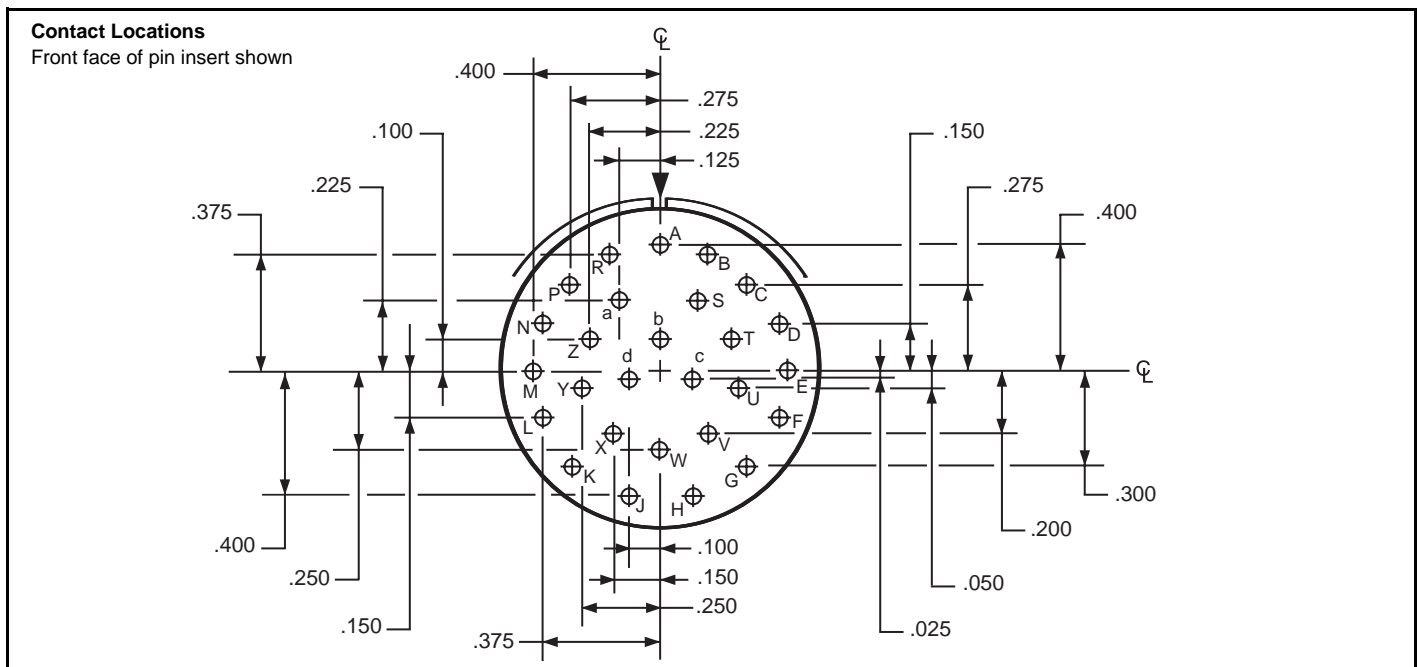

All dimensions for reference only. For alternate rotations see pages 25 & 26.
 Note: Shown in this catalog are the most common insert patterns for PCB applications. For availability of other arrangements, consult Amphenol Corp., Sidney, NY.

Cylindrical Connectors with PCB contacts insert arrangements, cont.

Insert Arrangement #20-35 / 21-35

Connector Type:	JT MIL-DTL-38999 Series II	LJT MIL-DTL-38999 Series I	Tri-Start MIL-DTL-38999 Series III	MIL-C-26482 Series 1 & 2	MIL-5015
Insert Designation:	20-35	21-35	21-35	NA	NA

Number of Contacts	Contact Size	Service Rating
79	22D	M

Contact Locations
Front face of pin insert shown

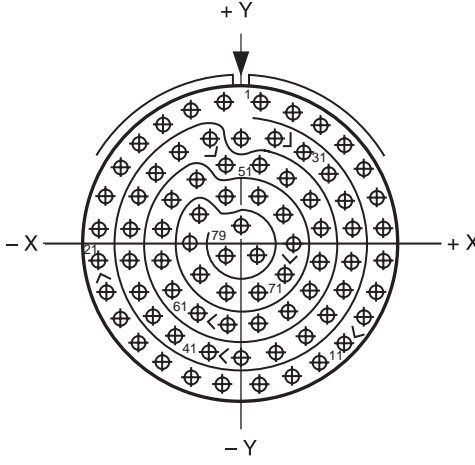

Contact Number	Location	
	X Axis	Y Axis
10	+0.365	-0.227
11	+0.306	-0.302
12	+0.232	-0.362
13	+0.146	-0.404
14	+0.053	-0.426
15	-0.053	-0.426
16	-0.146	-0.404
17	-0.232	-0.362
18	-0.306	-0.302
19	-0.365	-0.227
20	-0.406	-0.141
21	-0.427	-0.048
22	-0.427	+0.048
23	-0.406	+0.141
24	-0.365	+0.227
25	-0.306	+0.302
26	-0.232	+0.362
27	-0.146	+0.404
28	-0.053	+0.426
29	.000	+0.323
30	+0.098	+0.322
31	+0.184	+0.280
32	+0.258	+0.220
33	+0.311	+0.141
34	+0.332	+0.048
35	+0.332	-0.048
36	+0.311	-0.141
37	+0.258	-0.220
38	+0.184	-0.280
39	+0.098	-0.322
40	.000	-0.347
41	-0.098	-0.322
42	-0.184	-0.280
43	-0.258	-0.220
44	-0.311	-0.141

Contact Number	Location	
	X Axis	Y Axis
45	-0.332	-0.048
46	-0.332	+0.048
47	-0.311	+0.141
48	-0.258	+0.220
49	-0.184	+0.280
50	-0.098	+0.322
51	-0.048	+0.241
52	+0.048	+0.241
53	+0.134	+0.199
54	+0.208	+0.139
55	+0.237	+0.048
56	+0.237	-0.048
57	+0.208	-0.139
58	+0.134	-0.199
59	+0.048	-0.241
60	-0.048	-0.241
61	-0.134	-0.199
62	-0.208	-0.139
63	-0.237	-0.048
64	-0.237	+0.048
65	-0.208	+0.139
66	-0.134	+0.199
67	-0.048	+0.146
68	+0.048	+0.146
69	+0.125	+0.090
70	+0.155	.000
71	+0.125	-0.090
72	+0.048	-0.146
73	-0.048	-0.146
74	-0.125	-0.090
75	-0.155	.000
76	-0.125	+0.090
77	.000	+0.053
78	+0.048	-0.029
79	-0.048	-0.029

Contact Hole Locations		
Contact Number	Location	
	X Axis	Y Axis
1	+0.053	+0.426
2	+0.146	+0.404
3	+0.232	+0.362
4	+0.306	+0.302
5	+0.365	+0.227
6	+0.406	+0.141
7	+0.427	+0.048
8	+0.427	-0.048
9	+0.406	-0.141

All dimensions for reference only. For alternate rotations see pages 25 & 26.
 Note: Shown in this catalog are the most common insert patterns for PCB applications.
 For availability of other arrangements, consult Amphenol Corp., Sidney, NY.

Cylindrical Connectors with PCB contacts insert arrangements, cont.

Insert Arrangement #20-41 / 21-41

Connector Type:	JT MIL-DTL-38999 Series II	LJT MIL-DTL-38999 Series I	Tri-Start MIL-DTL-38999 Series III	MIL-C-26482 Series 1 & 2	MIL-5015
Insert Designation:	20-41	21-41	21-41	20-41	NA

Number of Contacts	Contact Size	Service Rating
41	20	I

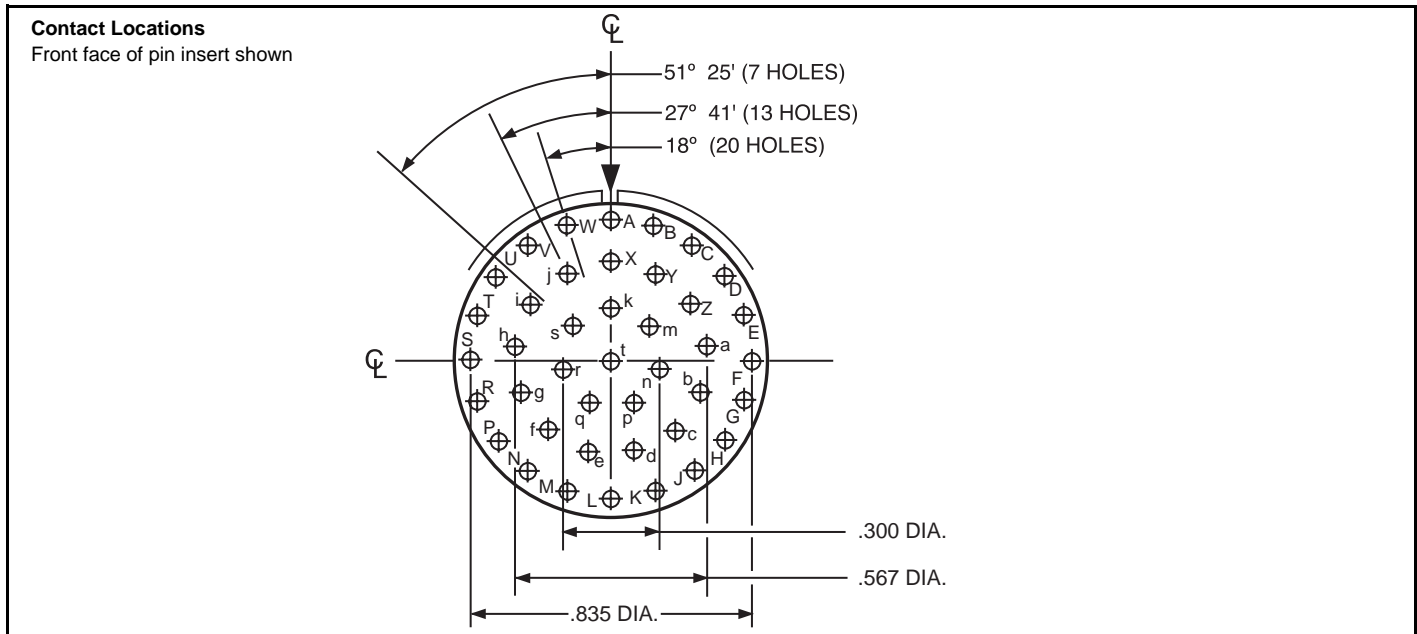

Insert Arrangement #22-14

Connector Type:	JT MIL-DTL-38999 Series II	LJT MIL-DTL-38999 Series I	Tri-Start MIL-DTL-38999 Series III	MIL-C-26482 Series 1 & 2	MIL-5015
Insert Designation:	NA	NA	NA	NA	22-14

Number of Contacts	Contact Size	Service Rating
19	16	A

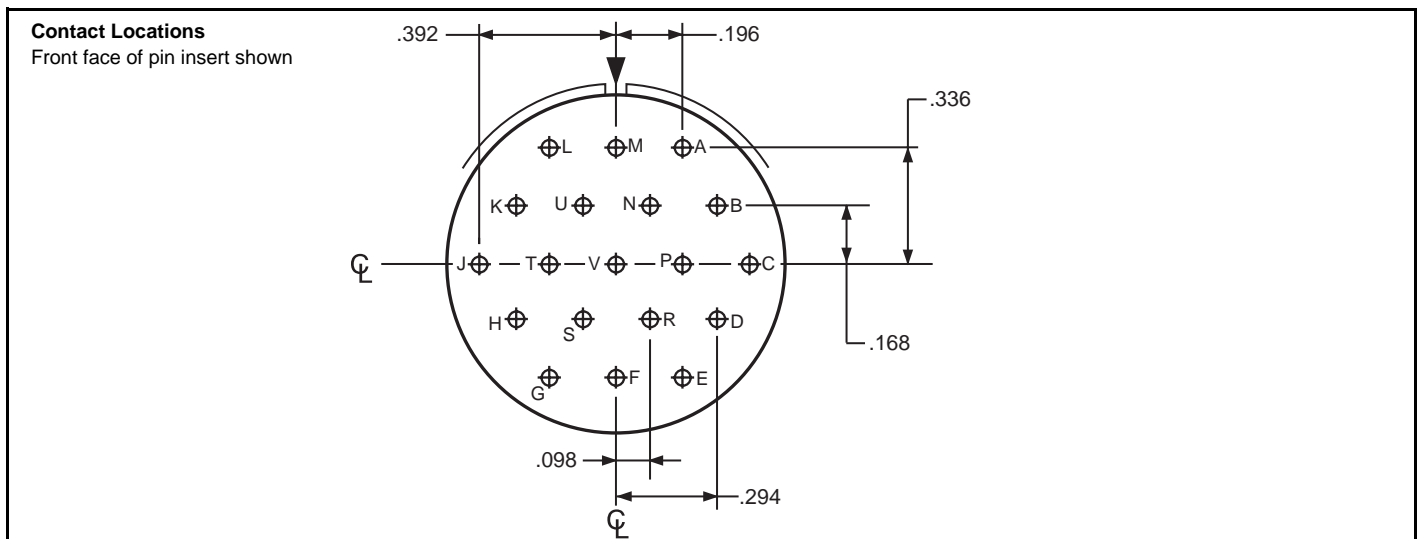

All dimensions for reference only. For alternate rotations see pages 25 & 26.
Note: Shown in this catalog are the most common insert patterns for PCB applications. For availability of other arrangements, consult Amphenol Corp., Sidney, NY.

Cylindrical Connectors with PCB contacts insert arrangements, cont.

Insert Arrangement #22-35 / 23-35

Connector Type:	JT MIL-DTL-38999 Series II	LJT MIL-DTL-38999 Series I	Tri-Start MIL-DTL-38999 Series III	MIL-C-26482 Series 1 & 2	MIL-5015
Insert Designation:	22-35	23-35	23-35	NA	NA

Number of Contacts	Contact Size	Service Rating
100	22D	M

Contact Locations
Front face of pin insert shown

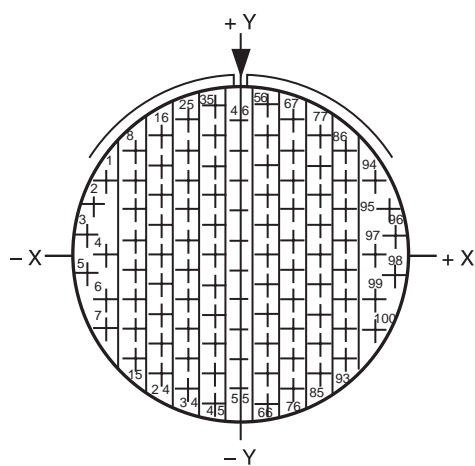

Contact Number	Location	
	X Axis	Y Axis
19	-.249	+.095
20	-.249	.000
21	-.249	-.095
22	-.249	-.190
23	-.249	-.285
24	-.249	-.380
25	-.166	+.428
26	-.166	+.333
27	-.166	+.238
28	-.166	+.143
29	-.166	+.048
30	-.166	-.047
31	-.166	-.142
32	-.166	-.237
33	-.166	-.332
34	-.166	-.427
35	-.083	+.475
36	-.083	+.380
37	-.083	+.285
38	-.083	+.190
39	-.083	+.095
40	-.083	.000
41	-.083	-.095
42	-.083	-.190
43	-.083	-.285
44	-.083	-.380
45	-.083	-.475
46	.000	+.428
47	.000	+.333
48	.000	+.238
49	.000	+.143
50	.000	+.048
51	.000	-.047
52	.000	-.142
53	.000	-.237
54	.000	-.332
55	.000	-.427
56	+.083	+.475
57	+.083	+.380
58	+.083	+.285
59	+.083	+.190
60	+.083	+.095

Contact Number	Location	
	X Axis	Y Axis
61	+.083	.000
62	+.083	-.095
63	+.083	-.190
64	+.083	-.285
65	+.083	-.380
66	+.083	-.475
67	+.166	+.428
68	+.166	+.333
69	+.166	+.238
70	+.166	+.143
71	+.166	+.048
72	+.166	-.047
73	+.166	-.142
74	+.166	-.237
75	+.166	-.332
76	+.166	-.427
77	+.249	+.380
78	+.249	+.285
79	+.249	+.190
80	+.249	+.095
81	+.249	.000
82	+.249	-.095
83	+.249	-.190
84	+.249	-.285
85	+.249	-.380
86	+.332	+.333
87	+.332	+.238
88	+.332	+.143
89	+.332	+.048
90	+.332	-.047
91	+.332	-.142
92	+.332	-.237
93	+.332	-.332
94	+.428	+.241
95	+.467	+.154
96	+.488	+.061
97	+.415	.000
98	+.488	-.061
99	+.428	-.142
100	+.428	-.237

Contact Hole Locations		
Contact Number	Location	
	X Axis	Y Axis
1	-.428	+.241
2	-.467	+.154
3	-.488	+.061
4	-.415	.000
5	-.488	-.061
6	-.428	-.142
7	-.428	-.237
8	-.332	+.333
9	-.332	+.238
10	-.332	+.143
11	-.332	+.048
12	-.332	-.047
13	-.332	-.142
14	-.332	-.237
15	-.332	-.332
16	-.249	+.380
17	-.249	+.285
18	-.249	+.190

All dimensions for reference only. For alternate rotations see pages 25 & 26.
 Note: Shown in this catalog are the most common insert patterns for PCB applications.
 For availability of other arrangements, consult Amphenol Corp., Sidney, NY.

Cylindrical Connectors with PCB contacts insert arrangements, cont.

Insert Arrangement #22-55 / 23-55

Connector Type:	JT MIL-DTL-38999 Series II	LJT MIL-DTL-38999 Series I	Tri-Start MIL-DTL-38999 Series III	MIL-C-26482 Series 1 & 2	MIL-5015
Insert Designation:	22-55	23-55	23-55	22-55	NA

Number of Contacts	Contact Size	Service Rating
55	20	I

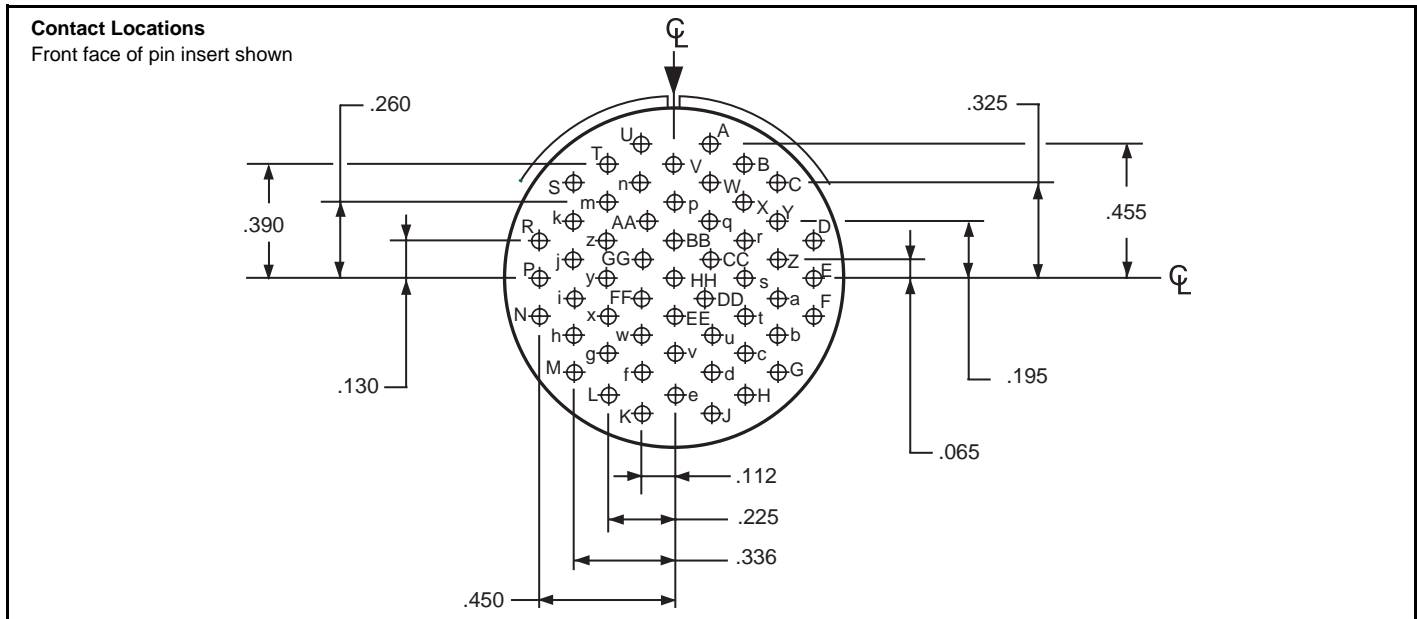

Insert Arrangement #24-5

Connector Type:	JT MIL-DTL-38999 Series II	LJT MIL-DTL-38999 Series I	Tri-Start MIL-DTL-38999 Series III	MIL-C-26482 Series 1 & 2	MIL-5015
Insert Designation:	NA	NA	NA	NA	24-5

Number of Contacts	Contact Size	Service Rating
16	16	A

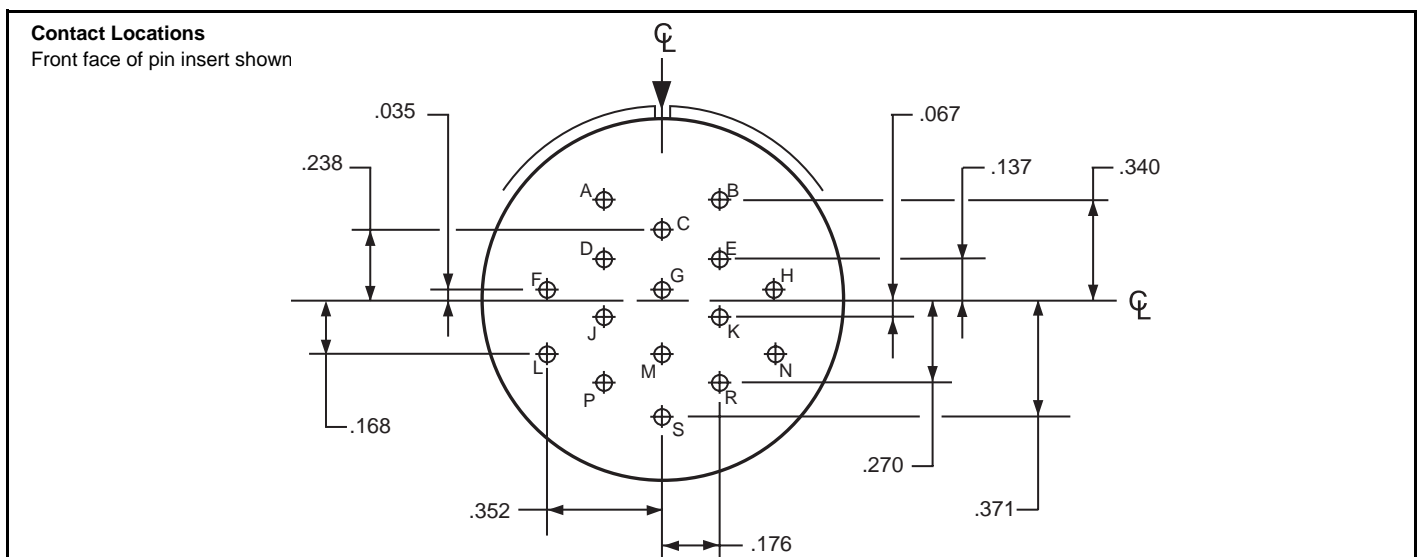

All dimensions for reference only. For alternate rotations see pages 25 & 26.
Note: Shown in this catalog are the most common insert patterns for PCB applications. For availability of other arrangements, consult Amphenol Corp., Sidney, NY.

Cylindrical Connectors with PCB contacts insert arrangements, cont.

Insert Arrangement #24-28

Connector Type:	JT MIL-DTL-38999 Series II	LJT MIL-DTL-38999 Series I	Tri-Start MIL-DTL-38999 Series III	MIL-C-26482 Series 1 & 2	MIL-5015
Insert Designation:	NA	NA	NA	NA	24-28

Number of Contacts	Contact Size	Service Rating
24	16	Inst.

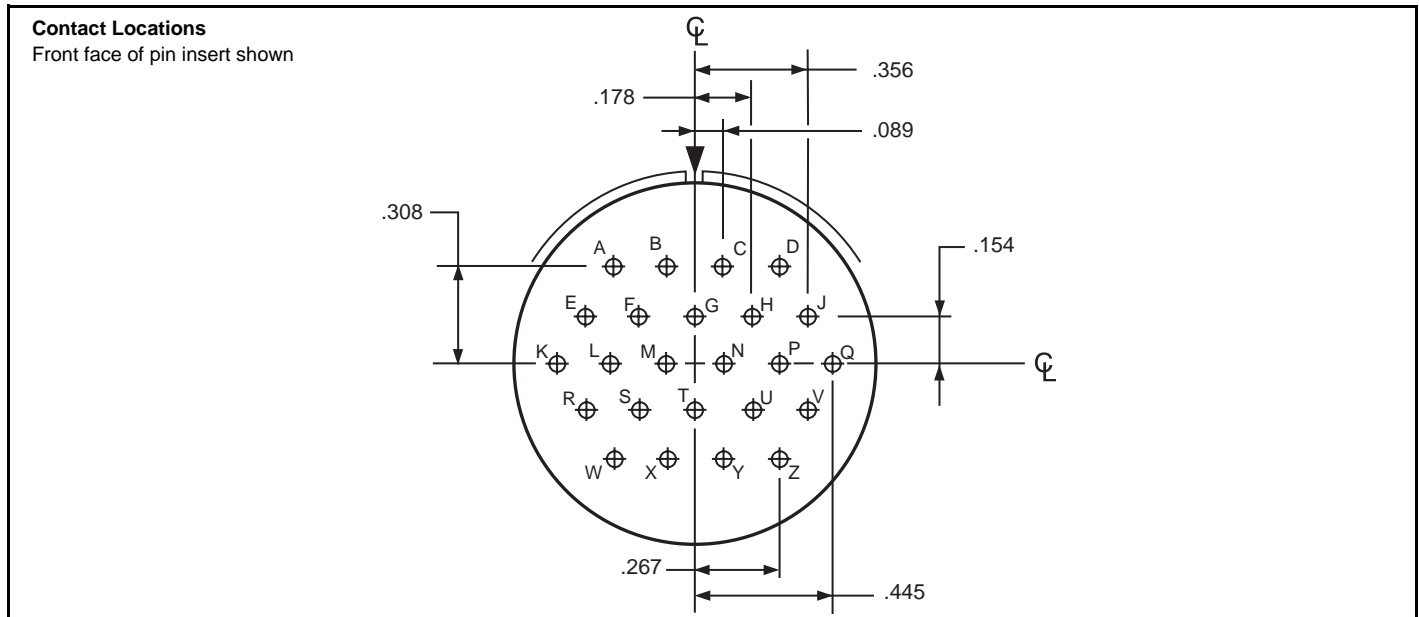

Insert Arrangement #24-31 / 25-31

Connector Type:	JT MIL-DTL-38999 Series II	LJT MIL-DTL-38999 Series I	Tri-Start MIL-DTL-38999 Series III	MIL-C-26482 Series 1 & 2	MIL-5015
Insert Designation:	24-31	NA	NA	24-31	NA

Number of Contacts	Contact Size	Service Rating
31	16	I

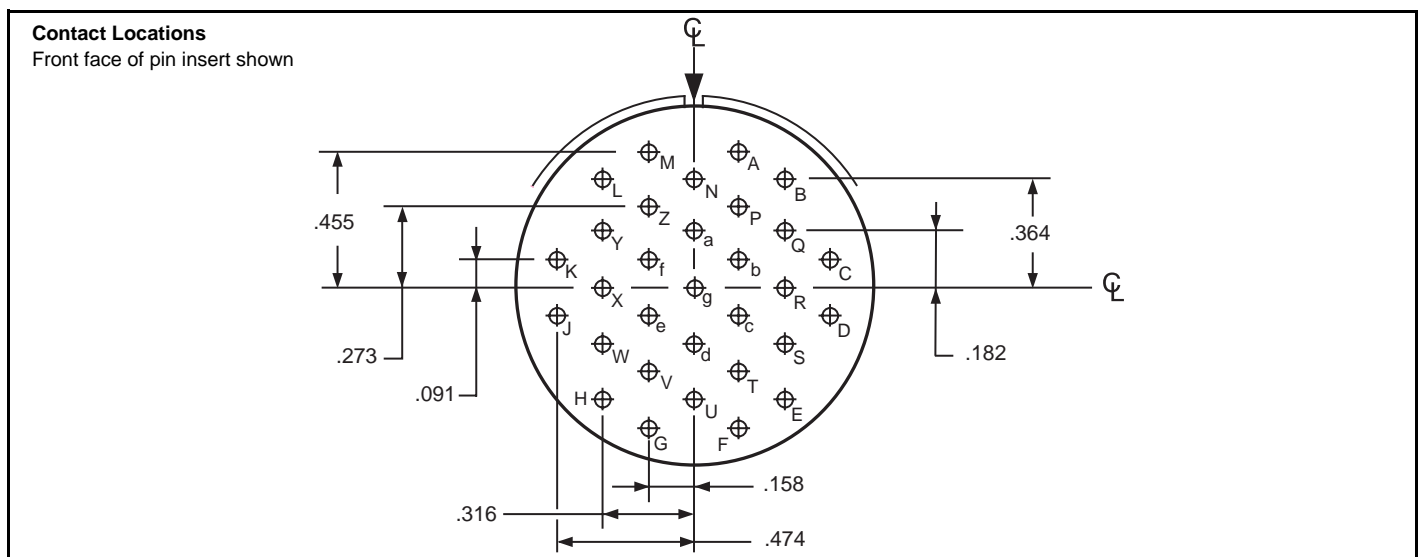

All dimensions for reference only. For alternate rotations see pages 25 & 26.
Note: Shown in this catalog are the most common insert patterns for PCB applications. For availability of other arrangements, consult Amphenol Corp., Sidney, NY.

Cylindrical Connectors with PCB contacts insert arrangements, cont.

Insert Arrangement #24-35 / 25-35

Connector Type:	JT MIL-DTL-38999 Series II	LJT MIL-DTL-38999 Series I	Tri-Start MIL-DTL-38999 Series III	MIL-C-26482 Series 1 & 2	MIL-5015
Insert Designation:	24-35	25-35	25-35	NA	NA

Number of Contacts	Contact Size	Service Rating
128	22D	M

Contact Locations
Front face of pin insert shown

Contact Hole Locations

Contact Number	Location	
	X Axis	Y Axis
28	-.249	+.190
29	-.249	+.095
30	-.249	.000
31	-.249	-.095
32	-.249	-.190
33	-.249	-.285
34	-.249	-.380
35	-.249	-.475
36	-.160	+.531
37	-.166	+.427
38	-.166	+.332
39	-.166	+.237
40	-.166	+.142
41	-.166	+.047
42	-.166	-.047
43	-.166	-.142
44	-.166	-.237
45	-.166	-.332
46	-.166	-.427
47	-.166	-.522
48	-.083	+.475
49	-.083	+.380
50	-.083	+.285
51	-.083	+.190
52	-.083	+.095
53	-.083	.000
54	-.083	-.095
55	-.083	-.190
56	-.083	-.285
57	-.083	-.380
58	-.083	-.475
59	.000	+.522
60	.000	+.427
61	.000	+.332
62	.000	+.237
63	.000	+.142
64	.000	+.047
65	.000	-.047
66	.000	-.142
67	.000	-.237
68	.000	-.332
69	.000	-.427
70	.000	-.522
71	+.083	+.475
72	+.083	+.380
73	+.083	+.285
74	+.083	+.190
75	+.083	+.095
76	+.083	.000
77	+.083	-.095

Contact Hole Locations

Contact Number	Location	
	X Axis	Y Axis
78	+.083	-.190
79	+.083	-.285
80	+.083	-.380
81	+.083	-.475
82	+.160	+.531
83	+.166	+.427
84	+.166	+.332
85	+.166	+.237
86	+.166	+.142
87	+.166	+.047
88	+.166	-.047
89	+.166	-.142
90	+.166	-.237
91	+.166	-.332
92	+.166	-.427
93	+.166	-.522
94	+.249	+.496
95	+.249	+.380
96	+.249	+.285
97	+.249	+.190
98	+.249	+.095
99	+.249	.000
100	+.249	-.095
101	+.249	-.190
102	+.249	-.285
103	+.249	-.380
104	+.249	-.475
105	+.332	+.444
106	+.332	+.332
107	+.332	+.237
108	+.332	+.142
109	+.332	+.047
110	+.332	-.047
111	+.332	-.142
112	+.332	-.237
113	+.332	-.332
114	+.332	-.427
115	+.424	+.357
116	+.415	+.190
117	+.415	+.095
118	+.415	.000
119	+.415	-.095
120	+.415	-.190
121	+.424	-.357
122	+.479	+.279
123	+.520	+.190
124	+.546	+.095
125	+.555	.000
126	+.546	-.095
127	+.520	-.190
128	+.479	-.279

All dimensions for reference only. For alternate rotations see pages 25 & 26.
 Note: Shown in this catalog are the most common insert patterns for PCB applications. For availability of other arrangements, consult Amphenol Corp., Sidney, NY.

Cylindrical Connectors with PCB contacts insert arrangements, cont.

Insert Arrangement #24-61 / 25-61

Connector Type:	JT MIL-DTL-38999 Series II	LJT MIL-DTL-38999 Series I	Tri-Start MIL-DTL-38999 Series III	MIL-C-26482 Series 1 & 2	MIL-5015
Insert Designation:	24-61	25-61	25-61	24-61	NA

Number of Contacts	Contact Size	Service Rating
61	20	I

Contact Locations
Front face of pin insert shown

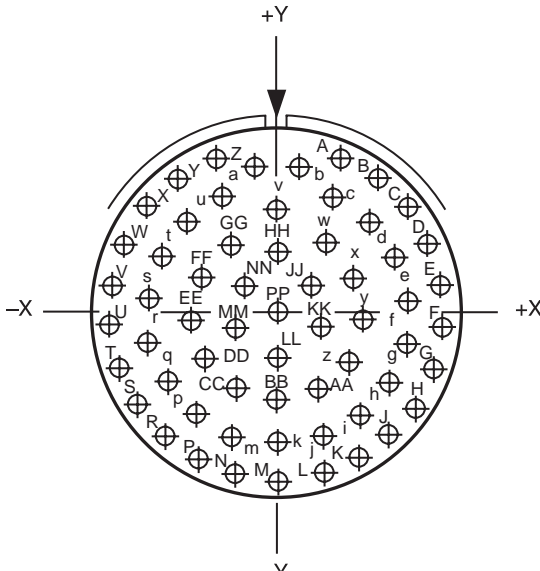

Contact Hole Locations		
Contact Number	Location	
	X Axis	Y Axis
A	+196	+500
B	+314	+435
C	+413	+343
D	+485	+230
E	+527	+101
F	+536	-.030
G	+511	-.164
H	+454	-.287
J	+368	-.391
K	+259	-.470
L	+134	-.519
M	.000	-.537
N	-.134	-.519
P	-.259	-.470
R	-.368	-.391
S	-.454	-.287
T	-.511	-.164
U	-.536	-.030
V	-.527	+101
W	-.485	+230
X	-.413	+343
Y	-.314	+435
Z	-.196	+500
a	-.068	+454
b	+068	+454
c	+173	+363
d	+285	+283
e	+362	+175
f	+399	+046
g	+392	-.088

Contact Hole Locations		
Contact Number	Location	
	X Axis	Y Axis
h	+341	-.213
i	+251	-.314
j	+133	-.379
k	.000	-.402
m	-.133	-.379
n	-.251	-.314
p	-.341	-.213
q	-.392	-.088
r	-.399	+046
s	-.362	+175
t	-.285	+283
u	-.173	+363
v	.000	+338
w	+147	+223
x	+237	+122
y	+267	-.010
z	+228	-.139
AA	+131	-.233
BB	.000	-.267
CC	-.131	-.233
DD	-.228	-.139
EE	-.267	-.010
FF	-.237	+122
GG	-.147	+223
HH	.000	+200
JJ	+105	+094
KK	+135	-.041
LL	.000	-.132
MM	-.135	-.041
NN	-.105	+094
PP	.000	.000

All dimensions for reference only. For alternate rotations see pages 25 & 26.
 Note: Shown in this catalog are the most common insert patterns for PCB applications.
 For availability of other arrangements, consult Amphenol Corp., Sidney, NY.

Cylindrical Connectors with PCB contacts insert arrangements, cont.

Insert Arrangement #28-15

Connector Type:	JT MIL-DTL-38999 Series II	LJT MIL-DTL-38999 Series I	Tri-Start MIL-DTL-38999 Series III	MIL-C-26482 Series 1 & 2	MIL-5015
Insert Designation:	NA	NA	NA	NA	28-15

Number of Contacts	Contact Size	Service Rating
35	16	A

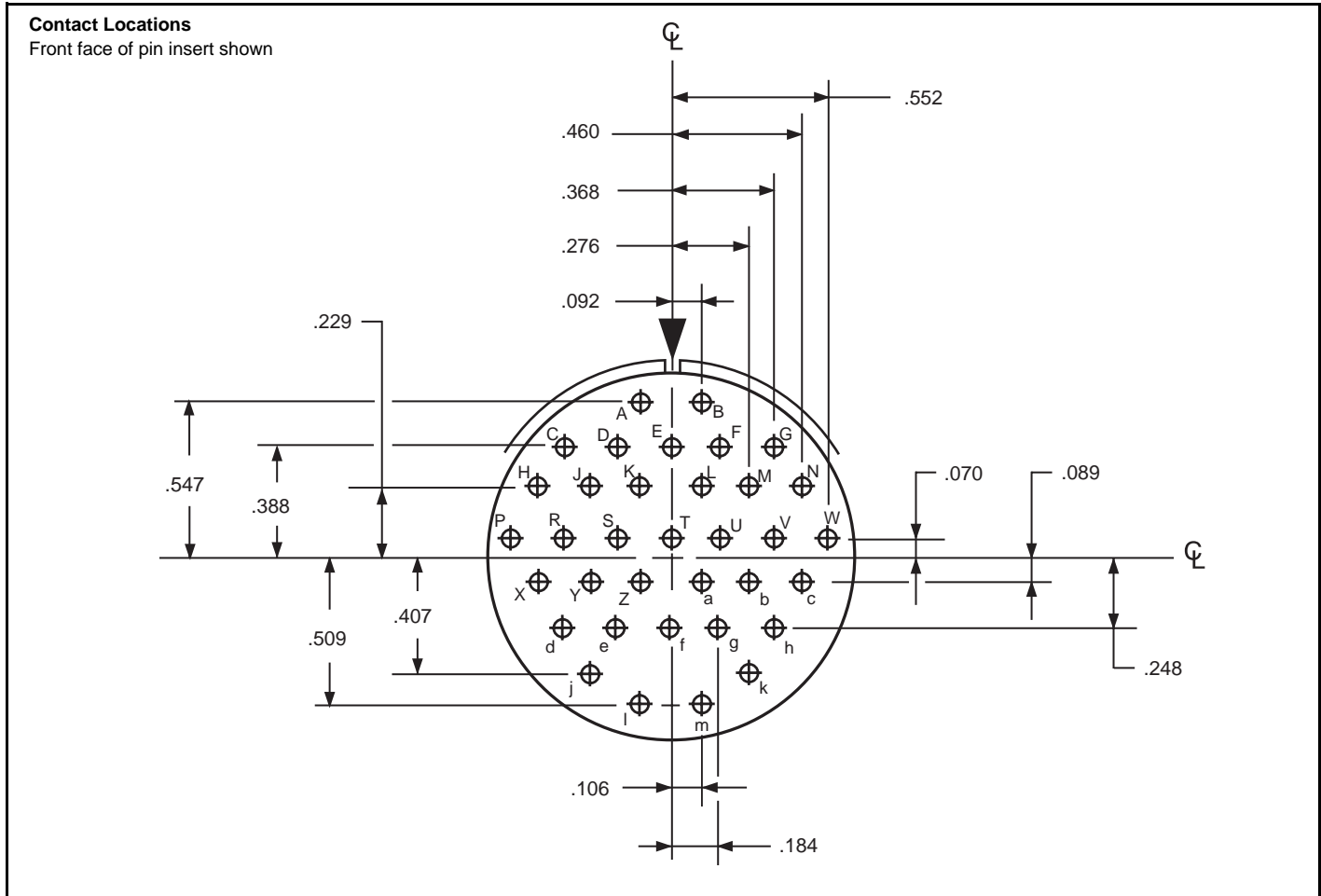

All dimensions for reference only. For alternate rotations see pages 25 & 26.
 Note: Shown in this catalog are the most common insert patterns for PCB applications.
 For availability of other arrangements, consult Amphenol Corp., Sidney, NY.

Cylindrical Connectors with PCB contacts alternate positioning available for MIL-DTL-38999 connectors

To avoid cross-plugging problems in applications requiring the use of more than one connector of the same series, size and arrangement, alternate rotations are available as indicated in the accompanying charts.

In MIL-DTL-38999 Series I, II and III connectors the rotation is based on rotating the master key/keyway in the connector shell.

A plug with a given rotation letter will mate with a receptacle with the same rotation letter. Only the master key/keyway rotates in the shell, and the insert always remains in the same position relative to the minor keys. Refer to diagrams below for each connector series.

LJT (MIL-DTL-38999 Series I) KEY/KEYWAY ROTATION

AB ANGLE OF ROTATION (Degrees)					
Shell Size	Normal°	A°	B°	C°	D°
9	95	77	-	-	113
11	95	81	67	123	109
13	95	75	63	127	115
15	95	74	61	129	116
17	95	77	65	125	113
19	95	77	65	125	113
21	95	77	65	125	113
23	95	80	69	121	110
25	95	80	69	121	110

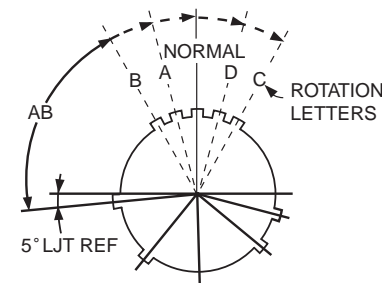

JT (MIL-DTL-38999 Series II) KEY/KEYWAY ROTATION

AB ANGLE OF ROTATION (Degrees)					
Shell Size	Normal°	A°	B°	C°	D°
8	100	82	-	-	118
10	100	86	72	128	114
12	100	80	68	132	120
14	100	79	66	134	121
16	100	82	70	130	118
18	100	82	70	130	118
20	100	82	70	130	118
22	100	85	74	126	115
24	100	85	74	126	115

RELATIVE POSSIBLE POSITION OF ROTATED MASTER KEYWAY (front face of LJT connector receptacle shown)

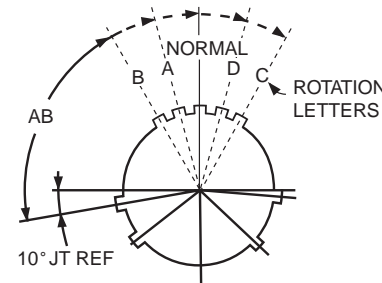

Tri-Start (MIL-DTL-38999 Series III) KEY/KEYWAY ROTATION

Shell Size	Key & Keyway Arrangement Identification Letter	AR° BSC	BR° BSC	CR° BSC	DR° BSC
9	N	105	140	215	265
	A	102	132	248	320
	B	80	118	230	312
	C	35	140	205	275
	D	64	155	234	304
11, 13, and 15	E	91	131	197	240
	N	95	141	208	236
	A	113	156	182	292
	B	90	145	195	252
	C	53	156	220	255
17 and 19	D	119	146	176	298
	E	51	141	184	242
	N	80	142	196	293
	A	135	170	200	310
	B	49	169	200	244
21, 23, and 25	C	66	140	200	257
	D	62	145	180	280
	E	79	153	197	272
	N	80	142	196	293
	A	135	170	200	310
21, 23, and 25	B	49	169	200	244
	C	66	140	200	257
	D	62	145	180	280
21, 23, and 25	E	79	153	197	272

RELATIVE POSSIBLE POSITION OF ROTATED MASTER KEYWAY (front face of JT connector receptacle shown)

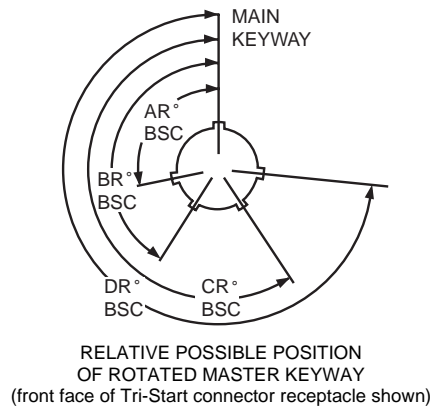

LJT & JT CONNECTORS ALTERNATE ROTATION CROSS REFERENCE LETTERS

Pins in Alternate Rotations	Sockets in Alternate Rotations
PA = E	SA = F
PB = R	SB = T
PC = W	SC = X
PD = Y	SD = Z

Explanation:
Use P at end of part number for pin contacts in Normal position.
Use S at end of part number for socket contacts in Normal position.
Use cross reference letters given in chart above for alternate rotations.

TRI-START CONNECTORS ALTERNATE ROTATION CROSS REFERENCE LETTERS

Pins in Alternate Rotations	Sockets in Alternate Rotations
PA = G	SA = H
PB = I	SB = J
PC = K	SC = L
PD = M	SD = N
PE = R	SE = T

Explanation:
Use P at end of part number for pin contacts in Normal position.
Use S at end of part number for socket contacts in Normal position.
Use cross reference letters given in chart above for alternate rotations.

Cylindrical Connectors with PCB contacts alternate positioning available for MIL-C-26482 and MIL-5015 connectors

To avoid cross-plugging problems in applications requiring the use of more than one connector of the same series, size and arrangement, alternate rotations are available as indicated in the accompanying charts.

In MIL-C-26482 and MIL-5015 connectors the rotation is based on rotation of the insert within the connector.

A plug with a given rotation letter will mate with a receptacle with the same rotation letter. The front face of the pin insert is rotated within the shell in a clockwise direction from the normal shell key. Refer to diagram below for both MIL-C-26482 and MIL-C-5015 connectors.

MIL-C-26482 INSERT ROTATION

Shell Size	Insert Arrangement	Insert Rotation			
		Degrees			
		W	X	Y	Z
8	8-3	60	210	-	-
8	8-98	-	-	-	-
10	10-5	45	151	180	270
14	14-18	15	90	180	270
14	14-19	30	165	315	-
16	16-26	60	-	275	338
18	18-32	85	138	222	265
20	20-41	45	126	225	-
22	22-36	72	144	216	288
24	24-31	90	225	255	-
24	24-61	90	180	270	324

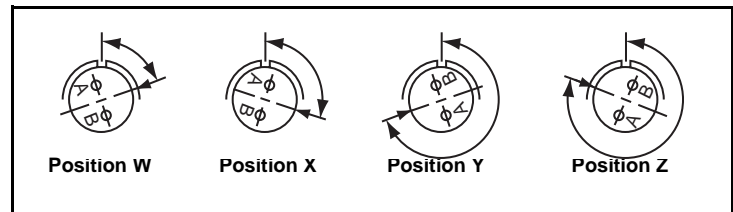

RELATIVE POSSIBLE POSITION OF ROTATED INSERT
(front face of connector receptacle shown)
(MIL-C-26482 and MIL-C-5015)

MIL-26482 AND MIL-5015 CONNECTORS ALTERNATE ROTATION CROSS REFERENCE LETTERS

Pins in Alternate Rotations	Sockets in Alternate Rotations
PW = G	SW = H
PX = I	SX = J
PY = K	SY = L
PZ = M	SZ = N

Explanation:
Use P at end of part number for pin contacts in Normal position.
Use S at end of part number for socket contacts in Normal position.
Use cross reference letters given in chart above for inserts with alternate rotations.

MIL-5015 INSERT ROTATION

Shell Size	Insert Arrangement	Insert Rotation			
		Degrees			
		W	X	Y	Z
10	10SL-3	-	-	-	-
14	14S-6	-	-	-	-
16	16S-1	80	-	-	280
18	18-1	70	145	215	290
20	20-11	-	-	-	-
22	22-14	80	110	250	280
24	24-28	80	110	250	280
28	28-15	80	110	250	280

MIL-DTL-38999 Series I Type Connectors with PCB contacts LJTPQ00R wall mounting receptacle (back panel mounting)

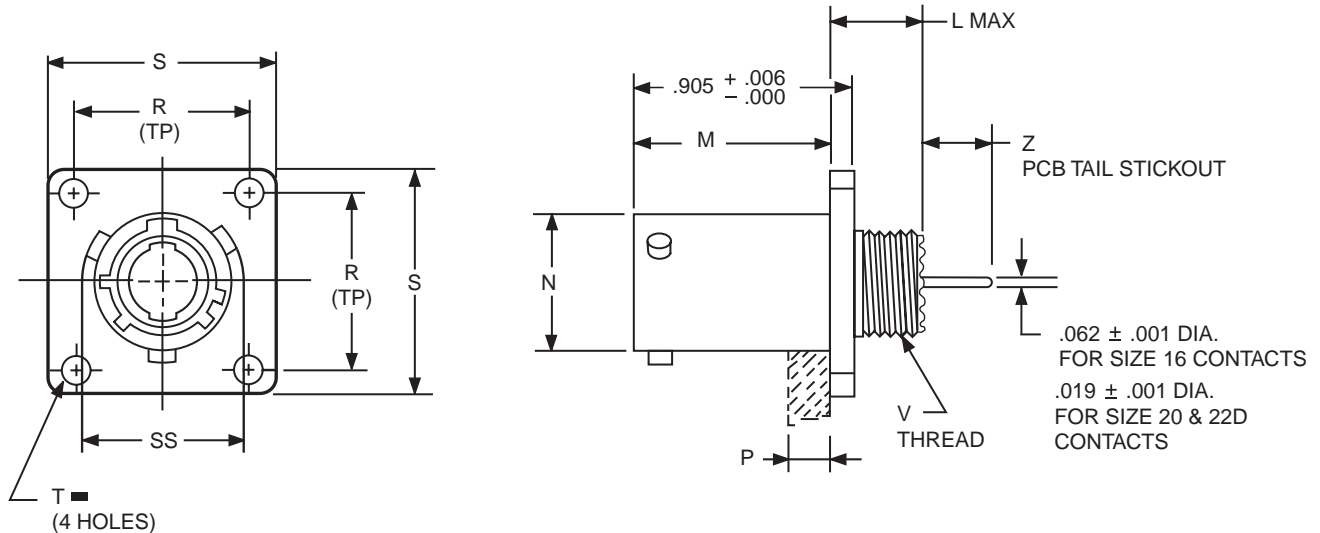

HOW TO ORDER

- Order by applicable 88/91 part number in table below.
88 prefix designates olive drab cadmium plated connector shell.
91 prefix designates electroless nickel plated connector shell.
- Add insert arrangement to end of number. Refer to insert availability chart on page 4 and pin-out illustrations on pages 4-24. Last letter of part number designates rotation; P for pins in normal position, S for sockets in normal position. See page 25 for alternate rotation letter to use.
Example part number: 88-569701-35P designates shell size 9 with a 9-35 insert and pin contacts in normal position.
- Z dimension is determined by contact type in the insert arrangement.
- Most common options are shown; other options are available.

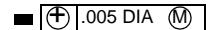

Shell Size	Part Number	L Max.	M +.000 -.005	N Dia.	P Max. Panel Thickness	R (TP)	S +.011 -.010	T Dia. ±.005	V Thread Class 2A (Plated)	SS Dia. +.000 -.016	Z	
											Size 16 & 20 Contacts	Size 22D Contacts
9	88/91-569701-XXX	.453	.820	.572	.234	.719	.938	.128	.4375-28 UNEF	.662	.281 - .235	.249 - .188
11	702-XXX	.453	.820	.700	.234	.812	1.031	.128	.5625-24 UNEF	.810	.281 - .235	.249 - .188
13	703-XXX	.453	.820	.850	.234	.906	1.125	.128	.6875-24 UNEF	.960	.281 - .235	.249 - .188
15	704-XXX	.453	.820	.975	.234	.969	1.219	.128	.8125-20 UNEF	1.085	.281 - .235	.249 - .188
17	705-XXX	.453	.820	1.100	.234	1.062	1.312	.128	.9375-20 UNEF	1.210	.281 - .235	.249 - .188
19	706-XXX	.453	.820	1.207	.234	1.156	1.438	.128	1.0625-18 UNEF	1.317	.281 - .235	.249 - .188
21	707-XXX	.484	.790	1.332	.204	1.250	1.562	.128	1.1875-18 UNEF	1.442	.281 - .235	.249 - .188
23	708-XXX	.484	.790	1.457	.204	1.375	1.688	.147	1.3125-18 UNEF	1.567	.281 - .235	.249 - .188
25	709-XXX	.484	.790	1.582	.193	1.500	1.812	.147	1.4375-18 UNEF	1.692	.281 - .235	.249 - .188

All dimensions for reference only.

MIL-DTL-38999 Series I Type Connectors with PCB contacts LJTPQ00R wall mounting receptacle (back panel mounting) (with clinch nuts)

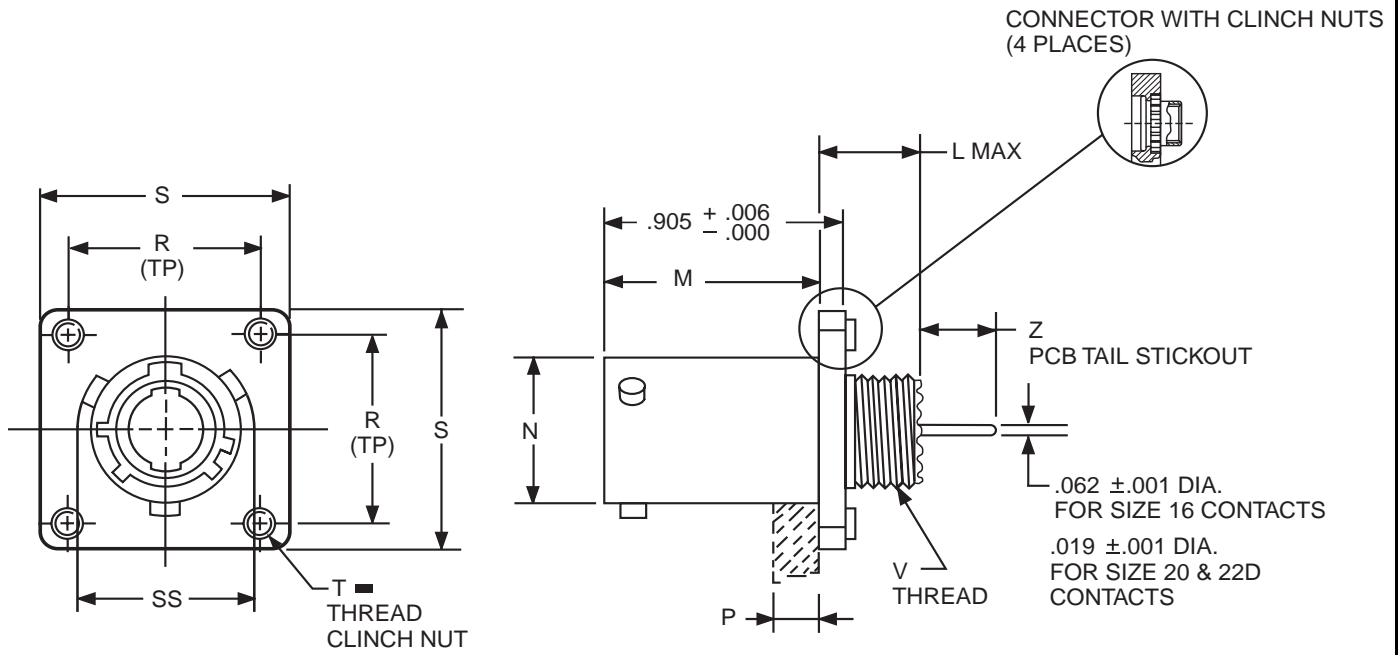

HOW TO ORDER

- Order by applicable 88/91 part number in table below.
88 prefix designates olive drab cadmium plated connector shell.
91 prefix designates electroless nickel plated connector shell.
- Add insert arrangement to end of number. Refer to insert availability chart on page 4 and pin-out illustrations on pages 4-24. Last letter of part number designates rotation; P for pins in normal position, S for sockets in normal position. See page 25 for alternate rotation letter to use.
Example part number: 88-628701-35P designates shell size 9 with a 9-35 insert and pin contacts in normal position.
- Z dimension is determined by contact type in the insert arrangement.
- Most common options are shown; other options are available.

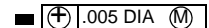

Shell Size	Part Number with Clinch Nuts*	L Max.	M +.000 - .005	N Dia.	P Max. Panel Thickness	R (TP)	S +.011 - .010	T Thread	V Thread Class 2A (Plated)	SS Dia. +.000 - .016	Z	
											Size 16 & 20 Contacts	Size 22D Contacts
9	88/91-628701-XXX	.453	.820	.572	.234	.719	.938	.112-40UNC-3B	.4375-28 UNEF	.662	.281 - .235	.249 - .188
11	702-XXX	.453	.820	.700	.234	.812	1.031	.112-40UNC-3B	.5625-24 UNEF	.810	.281 - .235	.249 - .188
13	703-XXX	.453	.820	.850	.234	.906	1.125	.112-40UNC-3B	.6875-24 UNEF	.960	.281 - .235	.249 - .188
15	704-XXX	.453	.820	.975	.234	.969	1.219	.112-40UNC-3B	.8125-20 UNEF	1.085	.281 - .235	.249 - .188
17	705-XXX	.453	.820	1.100	.234	1.062	1.312	.112-40UNC-3B	.9375-20 UNEF	1.210	.281 - .235	.249 - .188
19	706-XXX	.453	.820	1.207	.234	1.156	1.438	.112-40UNC-3B	1.0625-18 UNEF	1.317	.281 - .235	.249 - .188
21	707-XXX	.484	.790	1.332	.204	1.250	1.562	.112-40UNC-3B	1.1875-18 UNEF	1.442	.281 - .235	.249 - .188
23	708-XXX	.484	.790	1.457	.204	1.375	1.688	.138-32UNC-3B	1.3125-18 UNEF	1.567	.281 - .235	.249 - .188
25	709-XXX	.484	.790	1.582	.193	1.500	1.812	.138-32UNC-3B	1.4375-18 UNEF	1.692	.281 - .235	.249 - .188

All dimensions for reference only.

* Consult Amphenol for more information on ordering connectors with clinch nuts. There is also a 3mm clinch nut available (part number 88/91-628401/409)

MIL-DTL-38999 Series I Type Connectors with PCB contacts LJTP02R box mounting receptacle (back panel mounting)

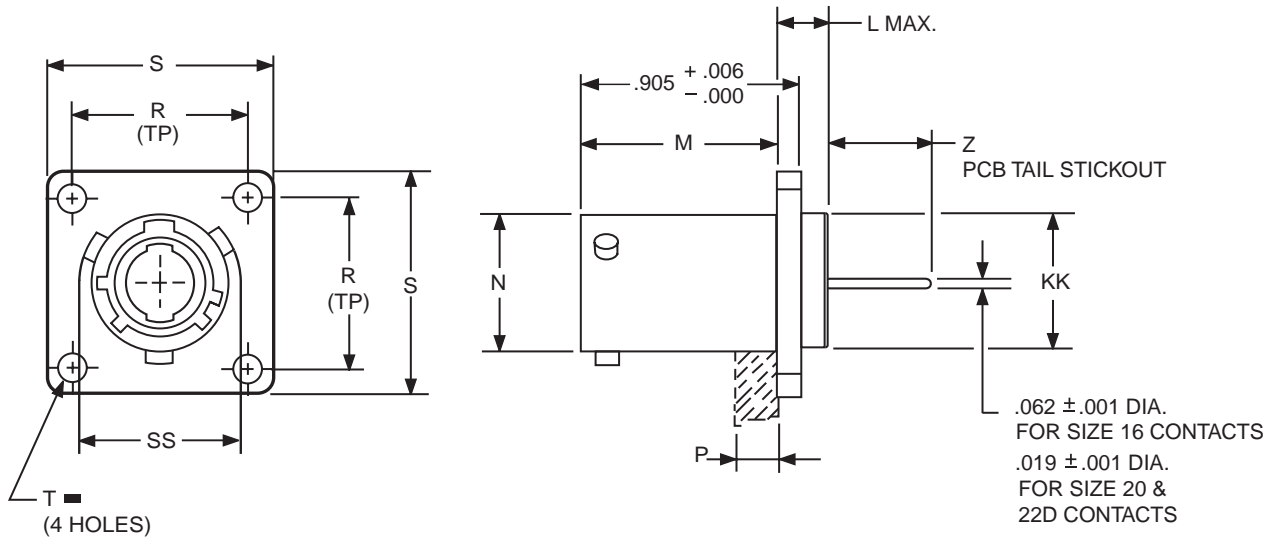

HOW TO ORDER

- Order by applicable 88/91 part number in table below.
88 prefix designates olive drab cadmium plated connector shell.
91 prefix designates electroless nickel plated connector shell.
- Add insert arrangement to end of number. Refer to insert availability chart on page 4 and pin-out illustrations on pages 4-24. Last letter of part number designates rotation; P for pins in normal position, S for sockets in normal position. See page 25 for alternate rotation letter to use.
Example part number: 88-569711-35P designates shell size 9 with a 9-35 insert and pin contacts in normal position.
- Z dimension is determined by contact type in the insert arrangement.
- Most common options are shown; other options are available.

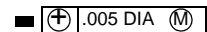

Shell Size	Part Number	L Max.	M +.000 -.005	N +.001 -.005	P Max. Panel Thickness	R (TP)	S +.011 -.010	T Dia. ±.005	KK Dia. +.006 -.005	SS Dia. +.000 -.016	Z	
											Size 16 & 20 Contacts	Size 22D Contacts
9	88/91-569711-XXX	.203	.820	.572	.234	.719	.938	.128	.433	.662	.454 - .401	.468 - .406
11	712-XXX	.203	.820	.700	.234	.812	1.031	.128	.557	.810	.454 - .401	.468 - .406
13	713-XXX	.203	.820	.850	.234	.906	1.125	.128	.676	.960	.454 - .401	.468 - .406
15	714-XXX	.203	.820	.975	.234	.969	1.219	.128	.801	1.085	.454 - .401	.468 - .406
17	715-XXX	.203	.820	1.100	.234	1.062	1.312	.128	.926	1.210	.454 - .401	.468 - .406
19	716-XXX	.203	.820	1.207	.234	1.156	1.438	.128	1.032	1.317	.454 - .401	.468 - .406
21	717-XXX	.234	.790	1.332	.204	1.250	1.562	.128	1.157	1.442	.454 - .401	.468 - .406
23	718-XXX	.234	.790	1.457	.204	1.375	1.688	.147	1.282	1.567	.454 - .401	.468 - .406
25	719-XXX	.234	.790	1.582	.193	1.500	1.812	.147	1.407	1.692	.454 - .401	.468 - .406

All dimensions for reference only.

MIL-DTL-38999 Series I Type Connectors with PCB contacts LJTP02R box mounting receptacle (back panel mounting) (with clinch nuts)

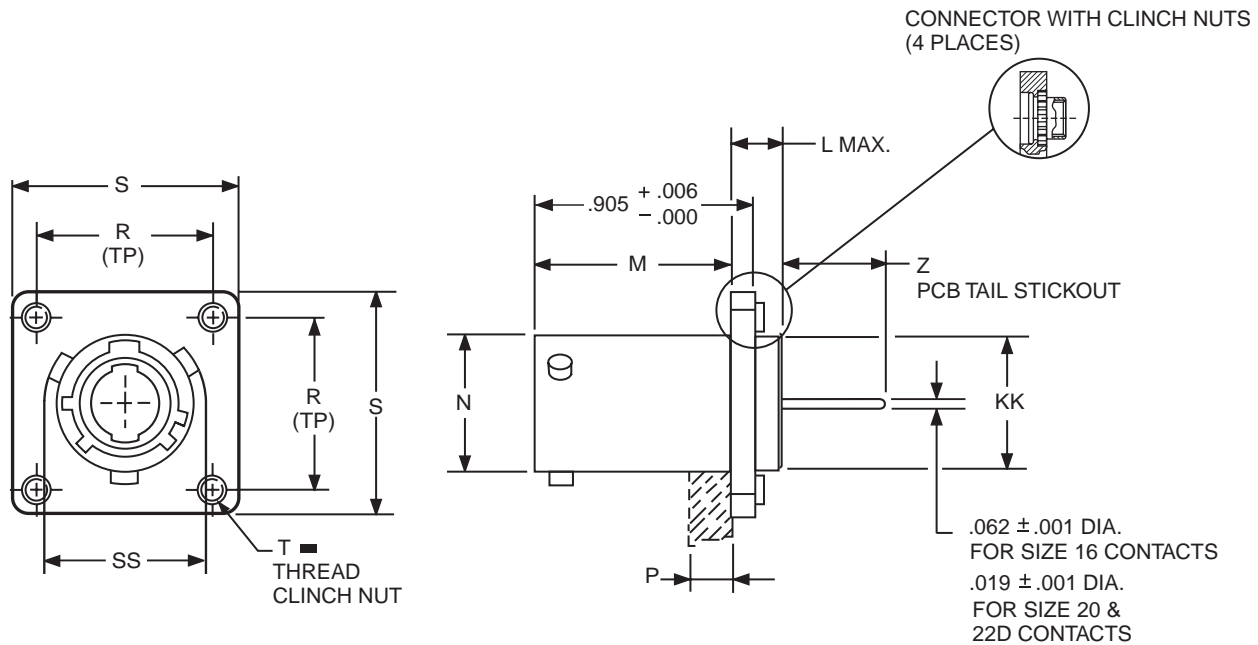

HOW TO ORDER

- Order by applicable 88/91 part number in table below.
88 prefix designates olive drab cadmium plated connector shell.
91 prefix designates electroless nickel plated connector shell.
- Add insert arrangement to end of number. Refer to insert availability chart on page 4 and pin-out illustrations on pages 5-24. Last letter of part number designates rotation; P for pins in normal position, S for sockets in normal position. See page 25 for alternate rotation letter to use.
Example part number: 88-628701-35P designates shell size 9 with a 9-35 insert and pin contacts in normal position.
- Z dimension is determined by contact type in the insert arrangement.
- Most common options are shown; other options are available.

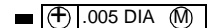

Shell Size	Part Number with Clinch Nuts	L Max.	M +.000 - .005	N +.001 - .005	P Max. Panel Thickness	R (TP)	S +.011 - .010	T Thread	KK Dia. +.006 - .005	SS Dia. +.000 - .016	Z	
											Size 16 & 20 Contacts	Size 22D Contacts
9	88/91-628711-XXX	.203	.820	.572	.234	.719	1.031	.112-40UNJC-3B	.433	.662	.454 - .401	.468 - .406
11	712-XXX	.203	.820	.700	.234	.812	1.125	.112-40UNJC-3B	.557	.810	.454 - .401	.468 - .406
13	713-XXX	.203	.820	.850	.234	.906	1.172	.112-40UNJC-3B	.676	.960	.454 - .401	.468 - .406
15	714-XXX	.203	.820	.975	.234	.969	1.281	.112-40UNJC-3B	.801	1.085	.454 - .401	.468 - .406
17	715-XXX	.203	.820	1.100	.234	1.062	1.375	.112-40UNJC-3B	.926	1.210	.454 - .401	.468 - .406
19	716-XXX	.203	.820	1.207	.234	1.156	1.469	.112-40UNJC-3B	1.032	1.317	.454 - .401	.468 - .406
21	717-XXX	.234	.790	1.332	.204	1.250	1.625	.112-40UNJC-3B	1.157	1.442	.454 - .401	.468 - .406
23	718-XXX	.234	.790	1.457	.204	1.375	1.750	.138-32UNJC-3B	1.282	1.567	.454 - .401	.468 - .406
25	719-XXX	.234	.790	1.582	.193	1.500	1.875	.138-32UNJC-3B	1.407	1.692	.454 - .401	.468 - .406

All dimensions for reference only.

* Consult Amphenol for more information on ordering connectors with clinch nuts. There is also a 3mm clinch nut available (part number 88/91-628410/419)

MIL-DTL-38999 Series I Type Connectors with PCB contacts LJT07R jam nut receptacle

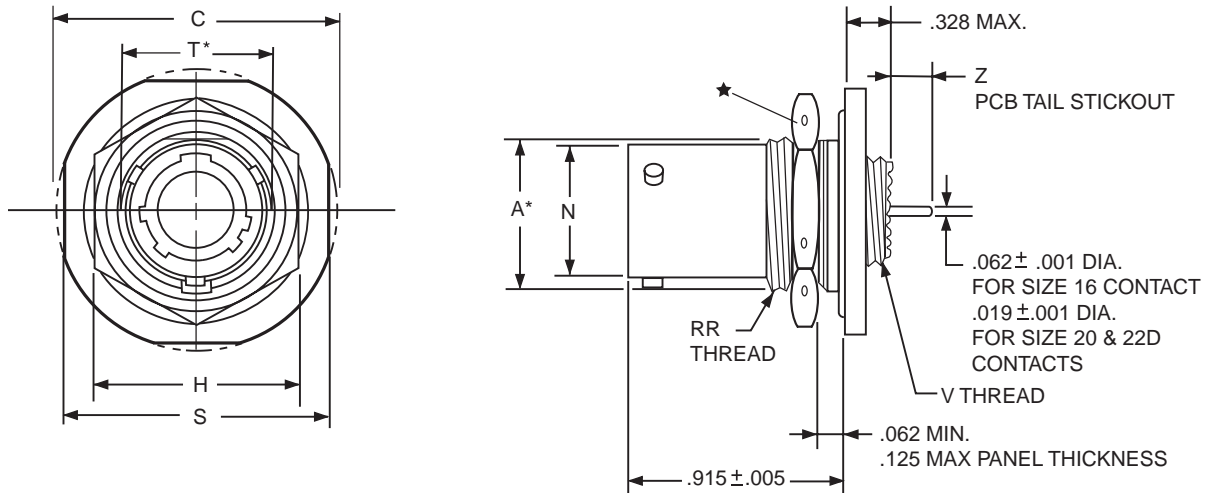

HOW TO ORDER

- Order by applicable 88/91 part number in table below.
88 prefix designates olive drab cadmium plated connector shell.
91 prefix designates electroless nickel plated connector shell.
- Add insert arrangement to end of number. Refer to insert availability chart on page 4 and pin-out illustrations on pages 4-24. Last letter of part number designates rotation; P for pins in normal position, S for sockets in normal position. See page 25 for alternate rotation letter to use.
Example part number: 88-569721-35P designates shell size 9 with a 9-35 insert and pin contacts in normal position.
- Z dimension is determined by contact type in the insert arrangement.
- Most common options are shown; other options are available.

- ★ .059 dia. min. 3 lockwire holes.
Formed lockwire hole design (6 holes) is optional.
- * "D" shaped mounting hole dimensions

Shell Size	Part Number	A* +.000 -.010	C Max.	H Hex +.017 -.016	L Max.	N +.001 -.005	S ±.016	T* +.010 -.000	V Thread Class 2A (Plated)	RR Thread Class 2A (Plated)	Z	
											Size 16 & 20 Contacts	Size 22D Contacts
9	88/91-569721-XXX	.669	1.199	.875	.625	.572	1.062	.697	.4375-28 UNEF	.6875-24 UNEF	.229 - .175	.243 - .182
11	722-XXX	.769	1.386	1.000	.625	.700	1.250	.822	.5625-24 UNEF	.8125-20 UNEF	.229 - .175	.243 - .182
13	723-XXX	.955	1.511	1.188	.625	.850	1.375	1.007	.6875-24 UNEF	1.0000-20 UNEF	.229 - .175	.243 - .182
15	724-XXX	1.084	1.636	1.312	.625	.975	1.500	1.134	.8125-20 UNEF	1.1250-18 UNEF	.229 - .175	.243 - .182
17	725-XXX	1.208	1.761	1.438	.625	1.100	1.625	1.259	.9375-20 UNEF	1.2500-18 UNEF	.229 - .175	.243 - .182
19	726-XXX	1.333	1.949	1.562	.656	1.207	1.812	1.384	1.0625-18 UNEF	1.3750-18 UNEF	.207 - .158	.221 - .165
21	727-XXX	1.459	2.073	1.688	.750	1.332	1.938	1.507	1.1875-18 UNEF	1.5000-18 UNEF	.207 - .158	.221 - .165
23	728-XXX	1.580	2.199	1.812	.750	1.457	2.062	1.634	1.3125-18 UNEF	1.6250-18 UNEF	.207 - .158	.221 - .165
25	729-XXX	1.709	2.323	2.000	.750	1.582	2.188	1.759	1.4375-18 UNEF	1.7500-18 UNS	.207 - .158	.221 - .165

All dimensions for reference only.

MIL-DTL-38999 Series II Type Connectors with PCB contacts JTPQ00R wall mounting receptacle (back panel mounting)

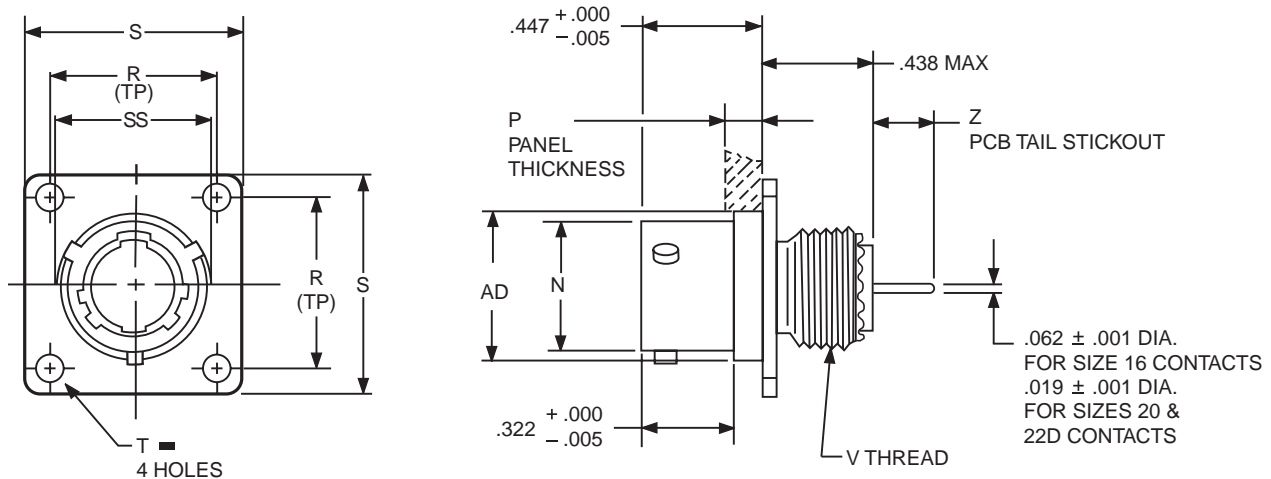

HOW TO ORDER

- Order by applicable 88/91 part number in table below.
88 prefix designates olive drab cadmium plated connector shell.
91 prefix designates electroless nickel plated connector shell.
- Add insert arrangement to end of number. Refer to insert availability chart on page 4 and pin-out illustrations on pages 4-24. Last letter of part number designates rotation; P for pins in normal position, S for sockets in normal position. See page 25 for alternate rotation letter to use.
Example part number: 88-569731-35P designates shell size 8 with a 8-35 insert and pin contacts in normal position.
- Z dimension is determined by contact type in the insert arrangement.
- Most common options are shown; other options are available.

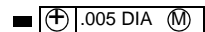

Shell Size	Part Number	N +.001 -.005	P Max. Panel Thickness	R (TP)	S ±.016	T Dia. ±.005	V Thread Class 2A (Plated)	AD Dia. ±.005	SS Dia. +.000 -.016	Z	
										Size 16 & 20 Contacts	Size 22D Contacts
8	88/91-569731-XXX	.473	.142	.594	.812	.120	.4375-28 UNEF	.516	.563	.257 - .200	.268 - .178
10	732-XXX	.590	.142	.719	.938	.120	.5625-24 UNEF	.633	.680	.257 - .200	.268 - .178
12	733-XXX	.750	.142	.812	1.031	.120	.6875-24 UNEF	.802	.859	.257 - .200	.268 - .178
14	734-XXX	.875	.142	.906	1.125	.120	.8125-20 UNEF	.927	.984	.257 - .200	.268 - .178
16	735-XXX	1.000	.142	.969	1.219	.120	.9375-20 UNEF	1.052	1.108	.257 - .200	.268 - .178
18	736-XXX	1.125	.142	1.062	1.312	.120	1.0625-18 UNEF	1.177	1.233	.257 - .200	.268 - .178
20	737-XXX	1.250	.142	1.156	1.438	.120	1.1875-18 UNEF	1.302	1.358	.257 - .200	.268 - .178
22	738-XXX	1.375	.142	1.250	1.562	.120	1.3125-18 UNEF	1.427	1.483	.257 - .200	.268 - .178
24	739-XXX	1.500	.142	1.375	1.688	.147	1.4375-18 UNEF	1.552	1.610	.257 - .200	.268 - .178

All dimensions for reference only.

MIL-DTL-38999 Series II Type Connectors with PCB contacts JTP02R box mounting receptacle (back panel mounting)

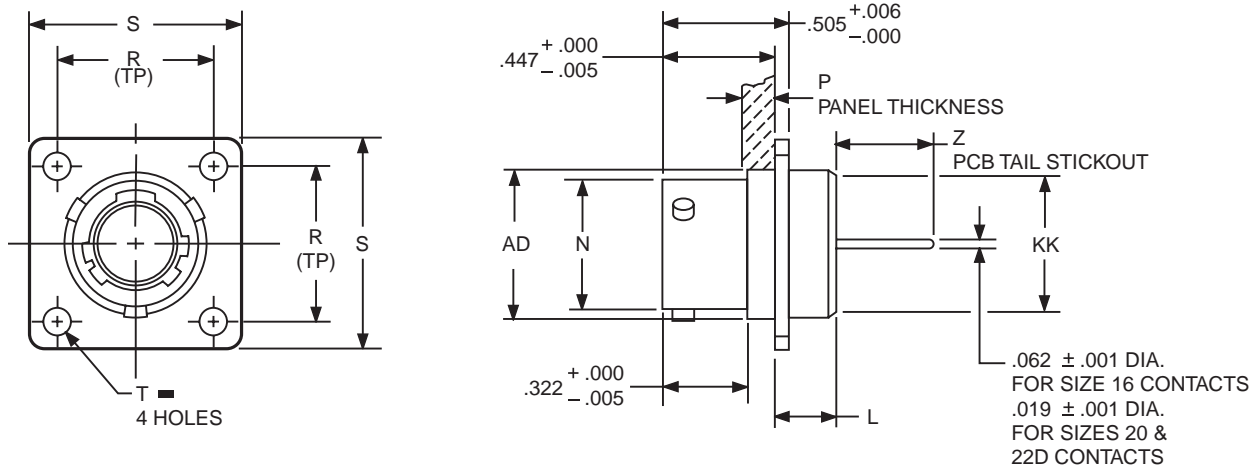

HOW TO ORDER

- Order by applicable 88/91 part number in table below.
88 prefix designates olive drab cadmium plated connector shell.
91 prefix designates electroless nickel plated connector shell.
- Add insert arrangement to end of number. Refer to insert availability chart on page 4 and pin-out illustrations on pages 4-24. Last letter of part number designates rotation; P for pins in normal position, S for sockets in normal position. See page 25 for alternate rotation letter to use.
Example part number: 88-569741-35P designates shell size 8 with a 8-35 insert and pin contacts in normal position.
- Z dimension is determined by contact type in the insert arrangement.
- Most common options are shown; other options are available.

⊕ .005 DIA (M)

Shell Size	Part Number	L Max.	N +.001 - .005	P Max. Panel Thickness	R (TP)	S ±.016	T Dia. ±.005	AD Dia. ±.005	KK Dia. Max.	Z	
										Size 16 & 20 Contacts	Size 22D Contacts
8	88/91-569741-XXX	.225	.473	.147	.594	.812	.120	.516	.531	.455 - .403	.466 - .409
10	742-XXX	.225	.590	.152	.719	.938	.120	.633	.656	.455 - .403	.466 - .409
12	743-XXX	.225	.750	.152	.812	1.031	.120	.802	.828	.455 - .403	.466 - .409
14	744-XXX	.225	.875	.152	.906	1.125	.120	.927	.953	.455 - .403	.466 - .409
16	745-XXX	.225	1.000	.152	.969	1.219	.120	1.052	1.078	.455 - .403	.466 - .409
18	746-XXX	.225	1.125	.152	1.062	1.312	.120	1.177	1.203	.455 - .403	.466 - .409
20	747-XXX	.225	1.250	.179	1.156	1.438	.120	1.302	1.328	.455 - .403	.466 - .409
22	748-XXX	.225	1.375	.179	1.250	1.562	.120	1.427	1.453	.455 - .403	.466 - .409
24	749-XXX	.225	1.500	.169	1.375	1.688	.147	1.552	1.578	.455 - .403	.466 - .409

All dimensions for reference only.