

High Power Bipolar Transistor

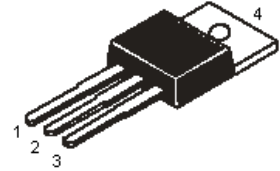
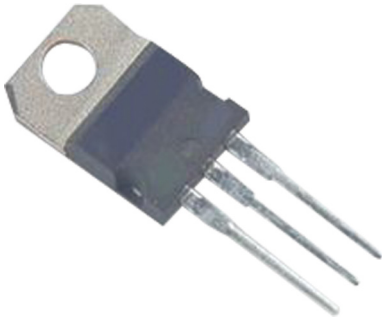

Pin Configuration:

- 1. Base
- 2. Collector
- 3. Emitter
- 4. Collector

Feature:

- NPN plastic power transistors
- General purpose amplifier and switching applications

Absolute Maximum Ratings:

Characteristic	Symbol		BD243C	Unit		
Collector-Base Voltage (Open Emitter)	V_{CBO}	Max.	100	V		
Collector Emitter Voltage (Open Base)	V_{CEO}					
Collector Current	I_C				6	A
Total Power Dissipation upto $T_C = 25^\circ\text{C}$	P_{tot}				65	W
Junction Temperature	T_j				150	$^\circ\text{C}$
Collector Current Saturation Voltage $I_C = 6\text{A}, I_B = 1\text{A}$	$V_{CE(Sat)}$	Min.	1.5	V		
DC Current Gain $I_C = 0.3\text{A}; V_{CE} = 4\text{V}$	h_{FE}				30	

Ratings (at $T_a = 25^\circ\text{C}$ unless otherwise specified) Limiting Values

Collector-Base Voltage (Open Emitter)	V_{CBO}	Max.	100	V
Collector Emitter Voltage (Open Base)	V_{CEO}			
Emitter-Base Voltage (Open Collector)	V_{EBO}			
Collector Current	I_C		6	A
Collector Current (Peak)			10	
Base Current	I_B		2	
Total Power Dissipation upto $T_C = 25^\circ\text{C}$	P_{tot}		65	W
Junction Temperature	T_j		150	$^\circ\text{C}$
Storage Temperature	T_{stg}		-65 to +150	



High Power Bipolar Transistor

Absolute Maximum Ratings:

Characteristic	Symbol		BD243C	Unit
Thermal Resistance				
From Junction to Case	$R_{th(j-c)}$	-	1.92	°C/W

Characteristics $T_a = 25^\circ\text{C}$ unless otherwise specified

Collector Cut off Current $I_B = 0; V_{CE} = 60V$ $V_{BE} = 0; V_{CE} = V_{CEO}$	I_{CEO} I_{CES}	Max.	0.7 0.4	mA
Emitter Cut off Current $I_C = 0; V_{EB} = 5V$	I_{EBO}		1	
Breakdown Voltages $I_C = 30mA; I_B = 0$ $I_C = 1mA; I_E = 0$ $I_E = 1mA; I_C = 0$	$V_{CEO(Sus)}^*$ V_{CBO} V_{EBO}	Min.	100 100 5	V
Saturation Voltage $I_C = 6A; I_B = 1A$	$V_{CE(sat)}^*$	Max.	1.5	
Base Emitter On Voltage $I_C = 6A; V_{CE} = 4V$	$V_{BE(on)}^*$		2	
DC Current Gain $I_C = 0.3A; V_{CE} = 4V$ $I_C = 3A; V_{CE} = 4V$	h_{FE}^*	Min.	30 15	-
Small Signal Current Gain $I_C = 0.5A; V_{CE} = 10V; f = 1kHz$	h_{fe}		20	
Transition Frequency $I_C = 0.5A; V_{CE} = 10V; f = 1MHz$	$f_T(1)$		3	

* Pulse Test: Pulse Width $\leq 300\mu s$; Duty Cycle $\leq 2\%$.

(1) $f_T = |h_{fe}| \cdot f_{test}$

High Power Bipolar Transistor

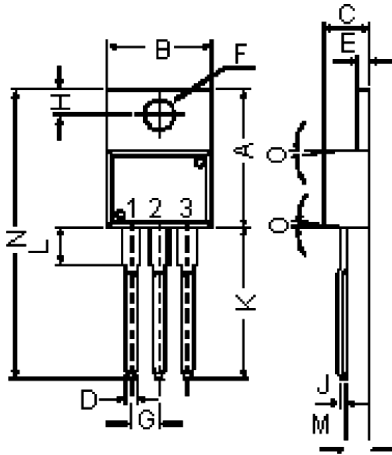

Pin Configuration:

1. Base
2. Collector
3. Emitter
4. Collector

Dimensions	Min.	Max.
A	14.42	16.51
B	9.63	10.67
C	3.56	4.83
D	-	0.9
E	1.15	1.4
F	3.75	3.88
G	2.29	2.79
H	2.54	3.43
J	-	0.56
K	12.7	14.73
L	2.8	4.07
M	2.03	2.92
N	-	31.24
O	7°	

Dimensions : Millimetres

Part Number Table

Description	Part Number
Transistor, NPN, TO-220	BD243C

Important Notice : This data sheet and its contents (the "Information") belong to the members of the Premier Farnell group of companies (the "Group") or are licensed to it. No licence is granted for the use of it other than for information purposes in connection with the products to which it relates. No licence of any intellectual property rights is granted. The Information is subject to change without notice and replaces all data sheets previously supplied. The Information supplied is believed to be accurate but the Group assumes no responsibility for its accuracy or completeness, any error in or omission from it or for any use made of it. Users of this data sheet should check for themselves the Information and the suitability of the products for their purpose and not make any assumptions based on information included or omitted. Liability for loss or damage resulting from any reliance on the Information or use of it (including liability resulting from negligence or where the Group was aware of the possibility of such loss or damage arising) is excluded. This will not operate to limit or restrict the Group's liability for death or personal injury resulting from its negligence. Multicomp is the registered trademark of the Group. © Premier Farnell plc 2012.