

## SAM3-P256 development board user's manual

All boards produced by Olimex are ROHS compliant

Rev. B, March 2013

Copyright(c) 2011, OLIMEX Ltd, All rights reserved

## INTRODUCTION:

Atmel's **ATSAM3S4BA-AU** is a member of a series of Flash microcontrollers based on the high performance 32-bit ARM Cortex-M3 RISC processor. It operates at a maximum speed of 64 MHz and features a 256 Kbyte Flash and a 48 Kbyte SRAM, Full Speed USB Device port with embedded transceiver, a High Speed MCI for SDIO/SD/MMC, an External Bus Interface featuring a Static Memory Controller providing connection to SRAM, PSRAM, NOR Flash and NAND Flash, 2x USARTs, 2xUARTs, 2xTWIs, 3xSPI, an I2S, as well as 1 PWM timer, 6x general-purpose 16-bit timers, an RTC, an ADC, a 12-bit DAC and an analog comparator.

**SAM3-P256** has JTAG, UEXT, USB and two RS232 connectors, power jack, potentiometer, two user buttons, two status LEDs, power-on led, reset button and prototype area for all microcontroller's ports. All this gives the customer chance to build a wide range of applications.

## BOARD FEATURES:

- ① Microcontroller: **ATSAM3S4BA-AU**.
- ① standard JTAG connector with ARM 2x10 pin layout for programming/debugging with ARM-JTAG
- ① USB connector
- ① Two channel RS232 interface and drivers
- ① SD/MMC card connector
- ① two buttons
- ① trimpot connected to ADC
- ① thermistor connected to ADC
- ① two status LEDs
- ① on board voltage regulator 3.3V with up to 800mA current
- ① single power supply: 6VDC or 4.5 VAC required
- ① power supply LED
- ① RESET circuit
- ① RESET button
- ① 12.000 Mhz crystal on socket
- ① UEXT connector
- ① prototype area for all microcontroller's ports
- ① PCB: FR-4, 1.5 mm (0,062"), red soldermask, silkscreen component print
- ① Dimensions: 120 x 80 mm (4.72 x 3.15")

## **ELECTROSTATIC WARNING:**

The **SAM3-P256** board is shipped in protective anti-static packaging. The board must not be subject to high electrostatic potentials. General practice for working with static sensitive devices should be applied when working with this board.

## **BOARD USE REQUIREMENTS:**

**Cables:** The cable you will need depends on the programmer/debugger you use. OLIMEX debuggers need USB type B to USB type A cable to connect to a computer.

**Hardware:** Programmer/Debugger [ARM-JTAG-COOCOX](#) or other compatible programming/debugging tool.

You can use also [ARM-USB-OCD](#), [ARM-USB-TINY](#), [ARM-USB-OCD-H](#), [ARM-USB-TINY-H](#) if you work with OpenOCD, IAR EW for ARM, Rowley Crossworks for ARM, CooCox, GCC compilers, etc.

## **PROCESSOR FEATURES:**

**SAM3-P256** board use ARM-based microcontroller **ATSAM3S4BA-AU** LQFP64 from Atmel Corporation with these features:

- Core
  - ARM® Cortex®-M3 revision 2.0 running at 64 MHz
  - Memory Protection Unit (MPU)
  - Thumb®-2 instruction set
- Pin-to-pin compatible with AT91SAM7S legacy products (48- and 64-pin versions)
- Memories
  - 256 Kbytes embedded Flash, 128-bit wide access, memory accelerator, single plane
  - 48 Kbytes embedded SRAM
  - 16 Kbytes ROM with embedded bootloader routines (UART, USB) and IAP routines
  - Memory Protection Unit (MPU)
- System
  - Embedded voltage regulator for single supply operation
  - Power-on-Reset (POR), Brown-out Detector (BOD) and Watchdog for safe operation

- Quartz or ceramic resonator oscillators: 3 to 20 MHz main power with Failure Detection and optional low power 32.768 kHz for RTC or device clock
- High precision 8/12 MHz factory trimmed internal RC oscillator with 4 MHz default frequency for device startup. In-application trimming access for frequency adjustment
- Slow Clock Internal RC oscillator as permanent low-power mode device clock
- Two PLLs up to 130 MHz for device clock and for USB
- Temperature Sensor
- Up to 22 peripheral DMA (PDC) channels
- Low Power Modes
  - Sleep and Backup modes, down to 3  $\mu$ A in Backup mode
  - Ultra low power RTC
- Peripherals
  - USB 2.0 Device: 12 Mbps, 2668 byte FIFO, up to 8 bidirectional Endpoints. On-Chip Transceiver
  - 2 USARTs with ISO7816, IrDA®, RS-485, SPI, Manchester and Modem Mode
  - Two 2-wire UARTs
  - 2 Two Wire Interface (I2C compatible), 1 SPI, 1 Serial Synchronous Controller (I2S), 1 High Speed Multimedia Card Interface (SDIO/SD Card/MMC)
  - 3 Three-Channel 16-bit Timer/Counter with capture, waveform, compare and PWM mode. Quadrature Decoder Logic and 2-bit Gray Up/Down Counter for Stepper Motor
  - 4-channel 16-bit PWM with Complementary Output, Fault Input, 12-bit Dead Time Generator Counter for Motor Control
  - 32-bit Real-time Timer and RTC with calendar and alarm features
  - 10-channel ADC with differential input mode and programmable gain stage
  - Two 12-bit DAC outputs
  - One Analog Comparator with flexible input selection, Selectable input hysteresis
  - 32-bit Cyclic Redundancy Check Calculation Unit (CRCCU)
- I/O
  - 47 I/O lines with external interrupt capability (edge or level sensitivity), debouncing, glitch filtering and on-die Series Resistor Termination

- Three 32-bit Parallel Input/Output Controllers, Peripheral DMA assisted Parallel Capture Mode

# BLOCK DIAGRAM:

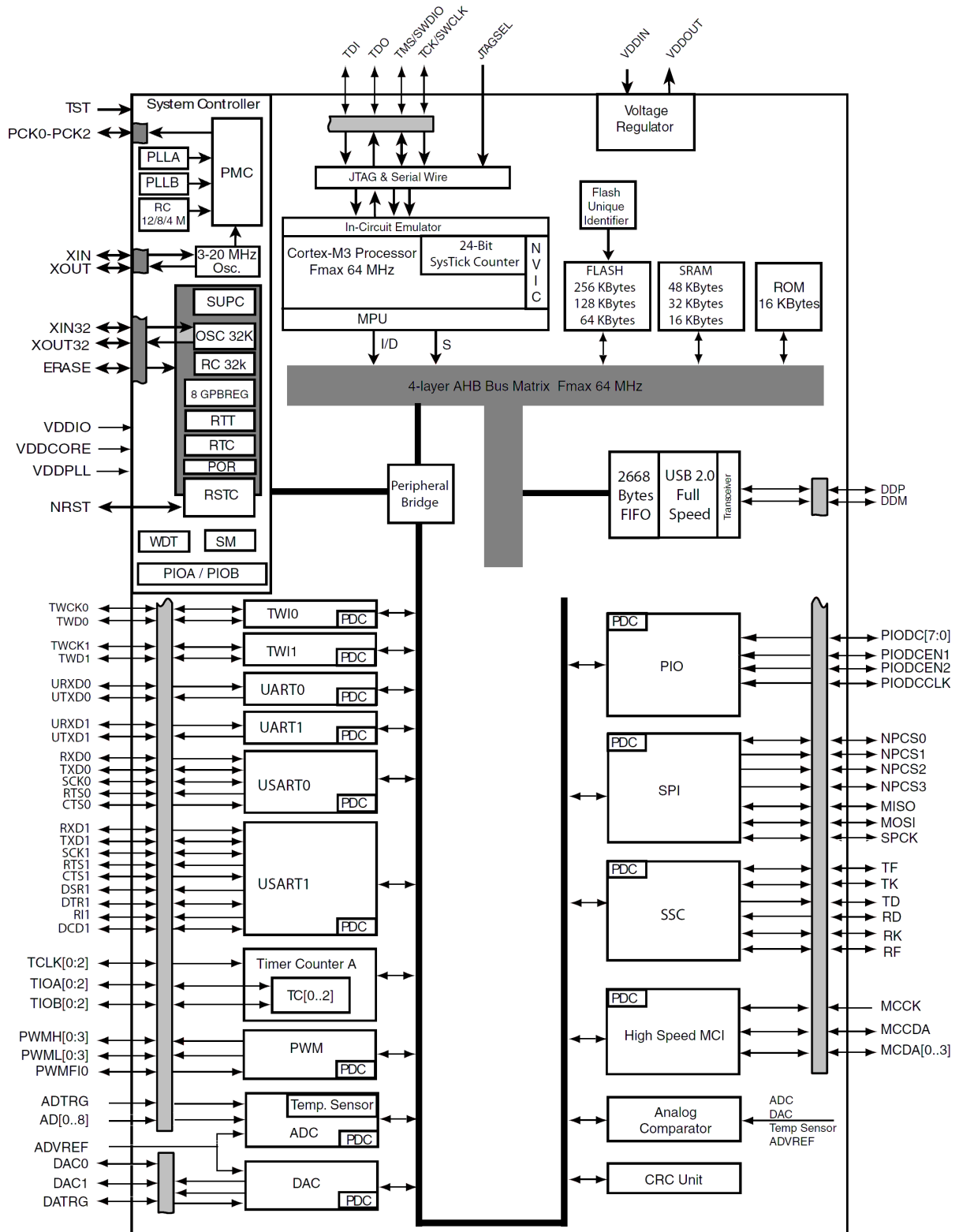

# MEMORY MAP:

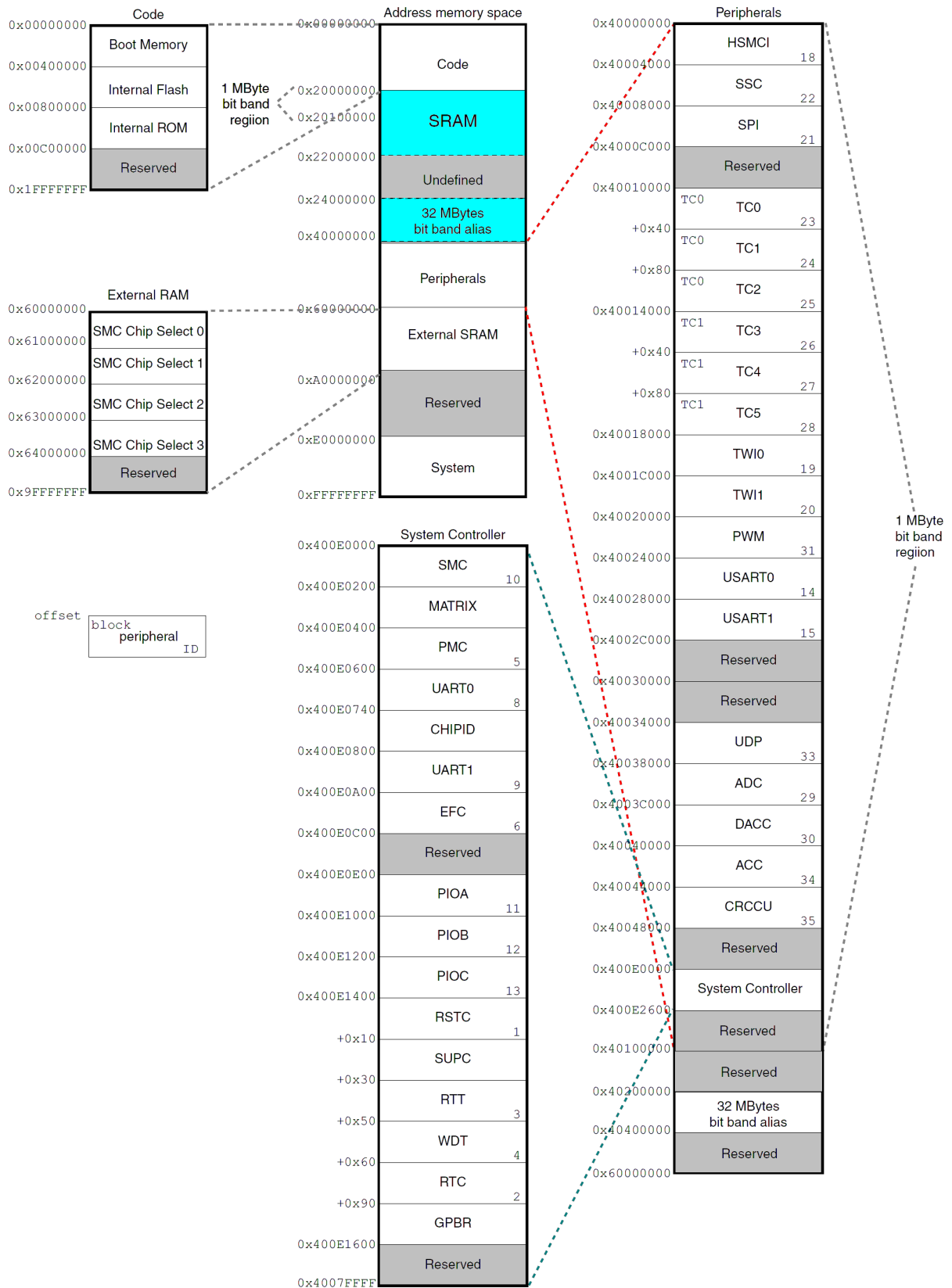

# SCHEMATIC:

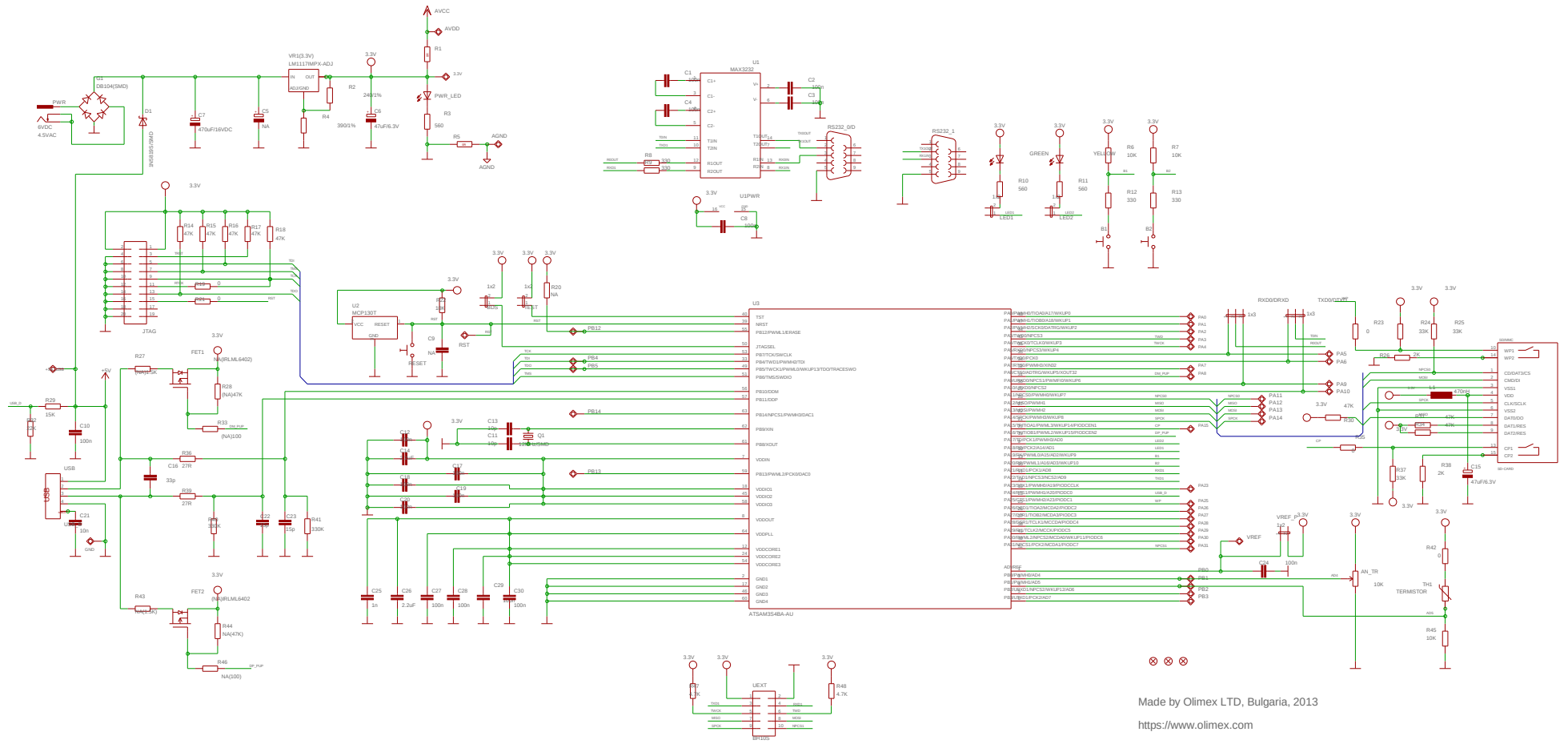

Made by Olimex LTD, Bulgaria, 2013  
<https://www.olimex.com>



# BOARD LAYOUT:

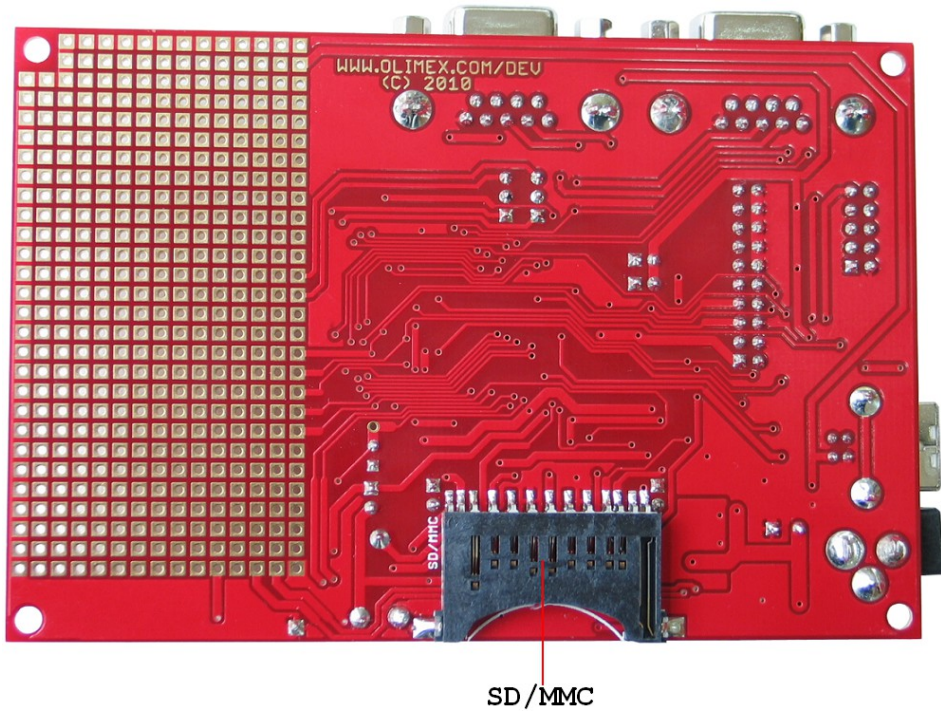
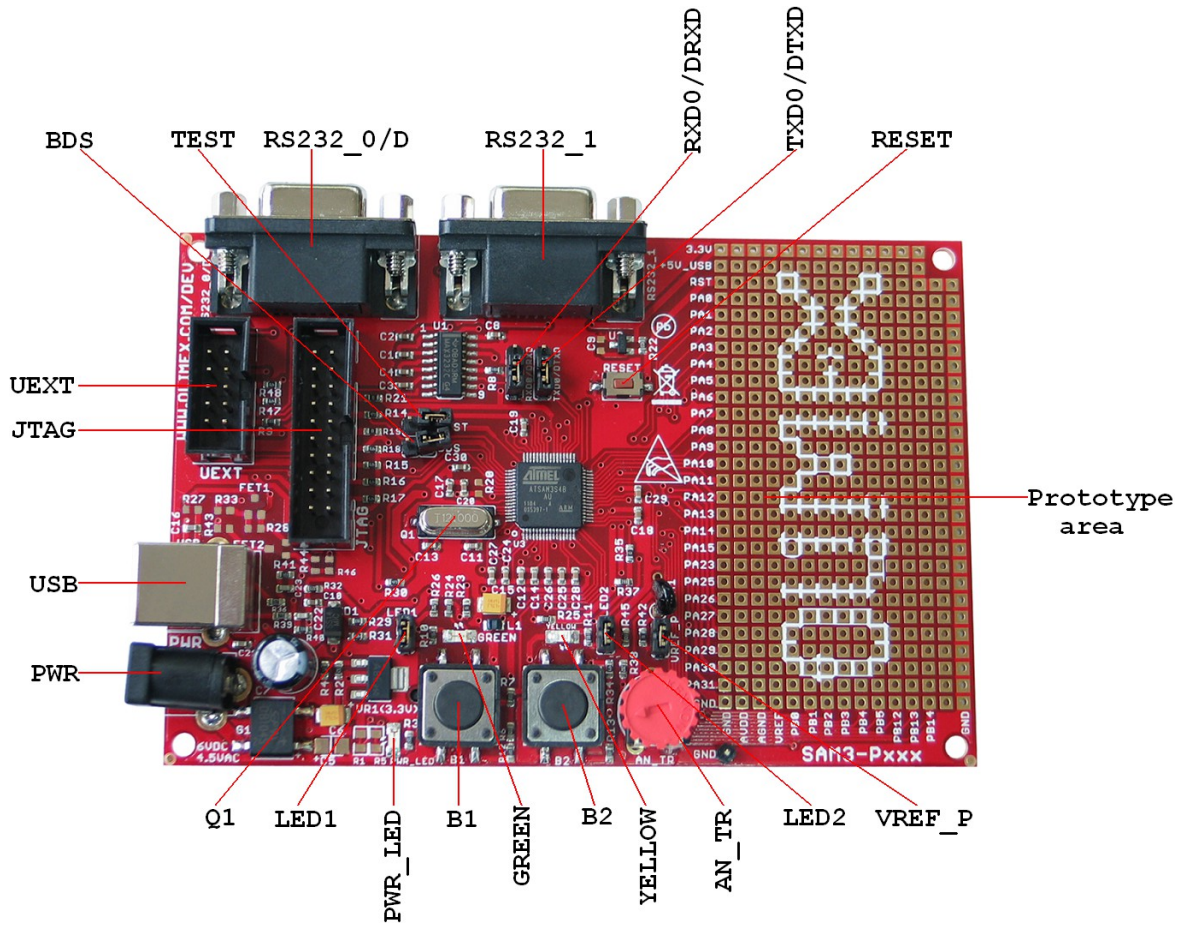

## **POWER SUPPLY CIRCUIT:**

**SAM3-P256** is typically power supplied with 6 VDC via Power jack, but it can be also power supplied via USB with +5V.

The programmed board power consumption is about 100 mA with all peripherals enabled.

## **RESET CIRCUIT:**

**SAM3-P256** reset circuit includes U2 (MCP130T), R22 (10k), pin 15 of JTAG connector, ATSAM3S4BA-AU pin 39 (NRST) and RESET button.

## **CLOCK CIRCUIT:**

Quartz crystal **Q1** 12.000 MHz is connected to ATSAM3S4BA-AU pin 61 (XOUT) and pin 62 (XIN).

## **JUMPER DESCRIPTION:**

### **BDS:**



This jumper, when is closed, connects ATSAM3S4BA-AU pin 50 (JTAGSEL) to VCC. The JTAGSEL pin is used to select the JTAG boundary scan when asserted at a high level.

When this jumper is opened, normal mode is enabled.

Default state is opened.

### **TEST:**



This jumper, when is closed, connects ATSAM3S4BA-AU pin 40 (TST) to VCC. The TST pin is used for JTAG Boundary Scan Manufacturing Test or Fast Flash programming mode.

When this jumper is opened, normal mode is enabled.

Default state is opened.

### **LED1:**



This jumper, when is closed, connects GREEN led to ATSAM3S4BA-AU pin 10 (PA18/RD/PCK2/A14/AD1).

When this jumper is opened GREEN led is not connected.

Default state is closed.

### **LED2:**



This jumper, when is closed, connects YELLOW led to ATSAM3S4BA-AU pin 9 (PA17/TD/PCK1/PWMH3/AD0).

When this jumper is opened YELLOW led is not connected.

Default state is closed.

### VREF\_P:



This jumper, when is closed, ATSAM3S4BA-AU pin1 (ADVREF) is connected to VCC (3.3V).

When this jumper is opened, ATSAM3S4BA-AU pin1 (ADVREF) is connected to VREF pin.

Default state is closed.

### RXD0/DRXD:



This jumper, when is in position RXD0, R0OUT is connected to ATSAM3S4BA-AU pin 35 (PA5/RXD0), i.e. RS232\_0/D is connected to RXD0.

When this jumper is in position DRXD, R0OUT is connected to ATSAM3S4BA-AU pin 30 (PA9/URXD0), i.e. RS232\_0/D is connected to DRXD. This is used in programming mode via COM Port using SAM-BA tool.

Default state is RXD0 shorted.

### TXD0/DTXD:



This jumper, when is in position TXD0, T0IN is connected to ATSAM3S4BA-AU pin 34 (PA6/TXD0), i.e. RS232\_0/D is connected to TXD0.

When this jumper is in position DTXD, T0IN is connected to ATSAM3S4BA-AU pin 29 (PA10/UTXD0), i.e. RS232\_0/D is connected to DTXD. This is used in programming mode via COM Port using SAM-BA tool.

Default state is TXD0 shorted.

## **Description for programming via RS232 0/D COM port, or USB port using SAM-BA software:**

Using SAM-BA software ATSAM3S4BA-AU can be programmed via COM port (with external power supply only), or via USB port (with USB power supply only). Before being able to use SAM-BA, a recovery procedure, which consists of copying the SAM-BA Boot Assistant into Flash must be performed as follows:

- 1.Power down the ATSAM3S4BA-AU
- 2.Short ATSAM3S4BA-AU pin 55 (PB12/ERASE) with 3.3V (you may do this by shorting R20)
- 3.Power up the ATSAM3S4BA-AU
- 4.Power down the ATSAM3S4BA-AU
- 5.Remove the short between ATSAM3S4BA-AU and 3.3V (R20)
- 6.Power up the ATSAM3S4BA-AU

Note: For programming via COM port, you must set jumpers RXD0/DRXD and TXD0/DTXD, according to jumpers description above, and the USB should not be plugged in.

## **INPUT/OUTPUT:**

**Status Led (green)** with name **GREEN** connected via jumper **LED1** to **ATSAM3S4BA-AU** pin 10 (PA18/RD/PCK2/A14/AD1)..

**Status Led (yellow)** with name **YELLOW** connected via jumper **LED2** to **ATSAM3S4BA-AU** pin 9 (PA17/TD/PCK1/PWMH3/AD0).

**Power-on LED (red)** with name **PWR\_LED** – this LED shows that +3.3V is applied to the board.

**User button** with name **B1** connected to **ATSAM3S4BA-AU** pin 13 (PA19/RK/PWML0/A15/AD2/WKUP9).

**User button** with name **B2** connected to **ATSAM3S4BA-AU** pin 16 (PA20/RF/PWML1/A16/AD3/WKUP10).

**User button** with name **RESET** connected to **ATSAM3S4BA-AU** pin 39 (NRST).

**Trimpot** with name **AN\_TR** connected to **ATSAM3S4BA-AU** pin 3 (PB0/AD4).

**Thermistor** with name **TH1** connected to **ATSAM3S4BA-AU** pin 4 (PB1/AD5).

**EXTERNAL CONNECTORS DESCRIPTION:**

**RS232 0/D:**

Pin #	Signal Name
1	NC
2	TX0OUT
3	RX0IN
4	NC
5	GND
6	NC
7	NC
8	NC
9	NC

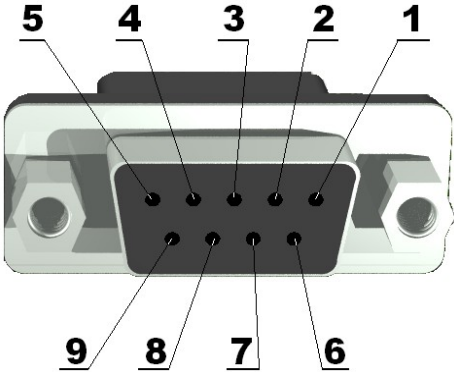

**RS232 1:**

Pin #	Signal Name
1	NC
2	TX1OUT
3	RX1IN
4	NC
5	GND
6	NC
7	NC
8	NC
9	NC

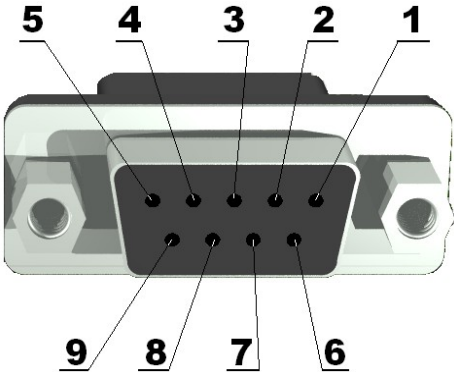

## PWR:

Pin #	Signal Name
1	Power Input
2	GND

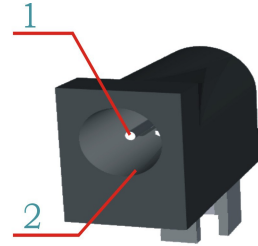

## UEXT:

Pin #	Signal Name
1	VCC
2	GND
3	TXD1
4	RXD1
5	TWCK
6	TWD
7	MISO
8	MOSI
9	SPCK
10	NPCS1

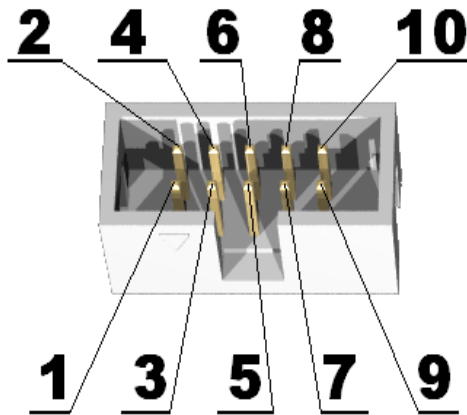

## JTAG:

The JTAG connector allows the software debugger to talk via a JTAG (Joint Test Action Group) port directly to the core. Instructions may be inserted and executed by the core thus allowing ATSAM3S4BA-AU memory to be programmed with code and executed step by step by the host software.

For more details refer to IEEE Standard 1149.1 - 1990 Standard Test Access Port and Boundary Scan Architecture and ATSAM3S4BA-AU datasheets and users manual.

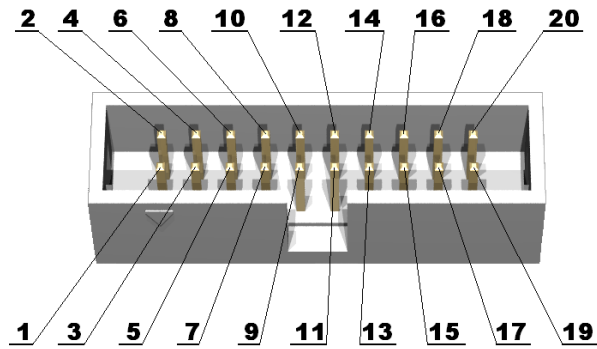

Pin #	Signal Name	Pin #	Signal Name
1	VCC	2	VCC
3	TRST	4	GND
5	TDI	6	GND
7	TMS	8	GND
9	TCK	10	GND
11	RTCK	12	GND
13	TDO	14	GND
15	RST	16	GND
17	NC	18	GND
19	NC	20	GND

**USB:**

Pin #	Signal Name
1	+5V_USB
2	DDM
3	DDP
4	GND

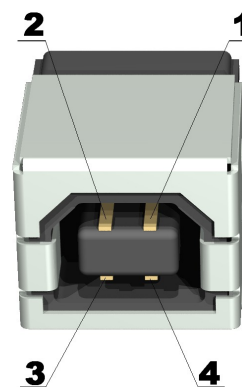

**SD/MMC:**

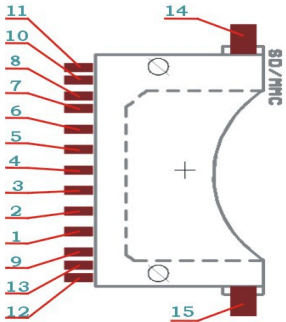

Pin #	Signal Name	Pin #	Signal Name
1	NPCS0	2	MOSI
3	GND (VSS1)	4	VDD
5	SPCK	6	GND (VSS2)
7	MISO	8	Via R31 (47k) to 3.3V
9	Via R34 (47k) to 3.3V	10	WP
11	Via R26 (2k) to GND	12	Via R38 (2k) to GND
13	CP	14	Via R26 (2k) to GND
15	Via R38 (2k) to GND		



Prototype area:

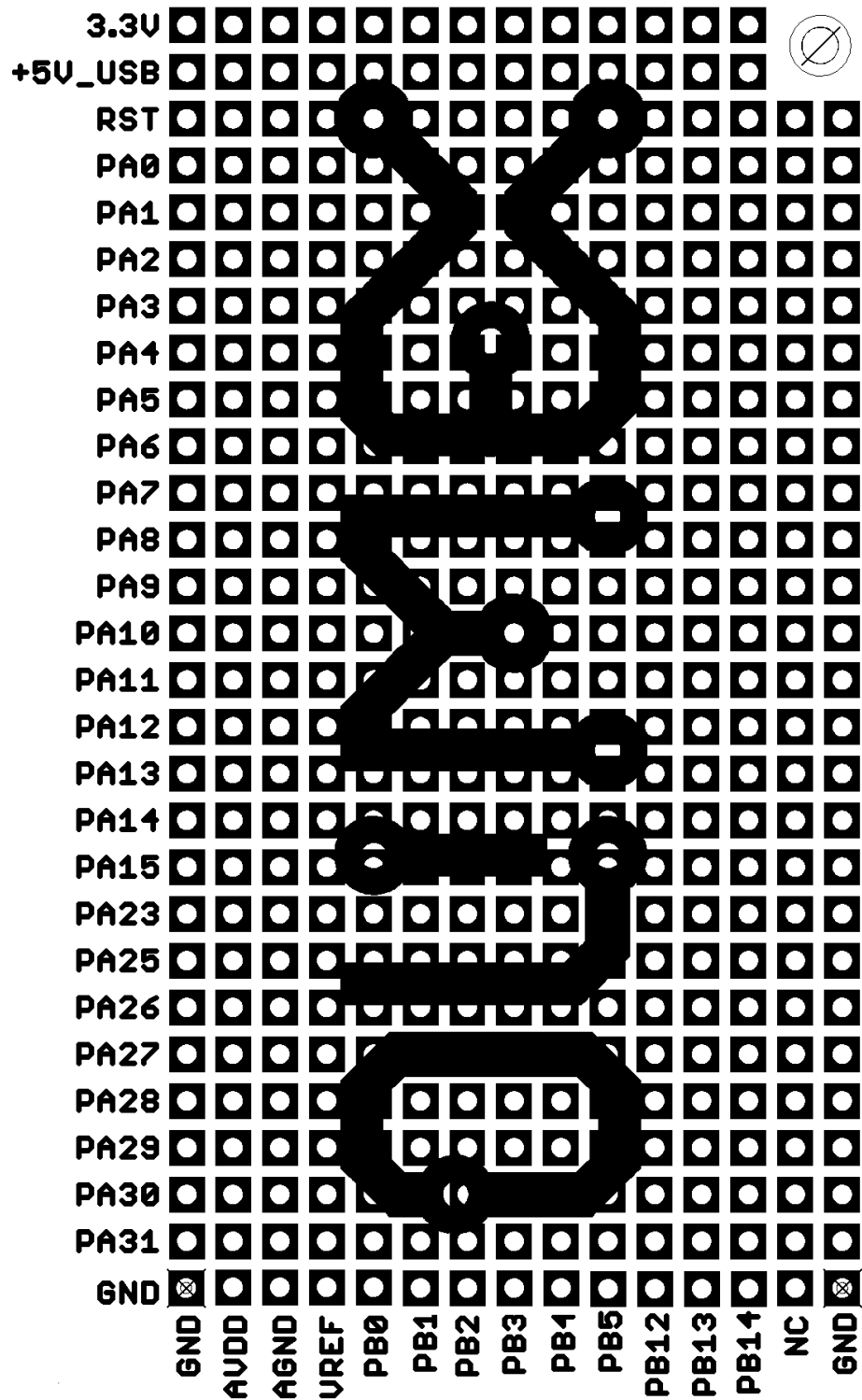

NC – Not connected.

# MECHANICAL DIMENSIONS:

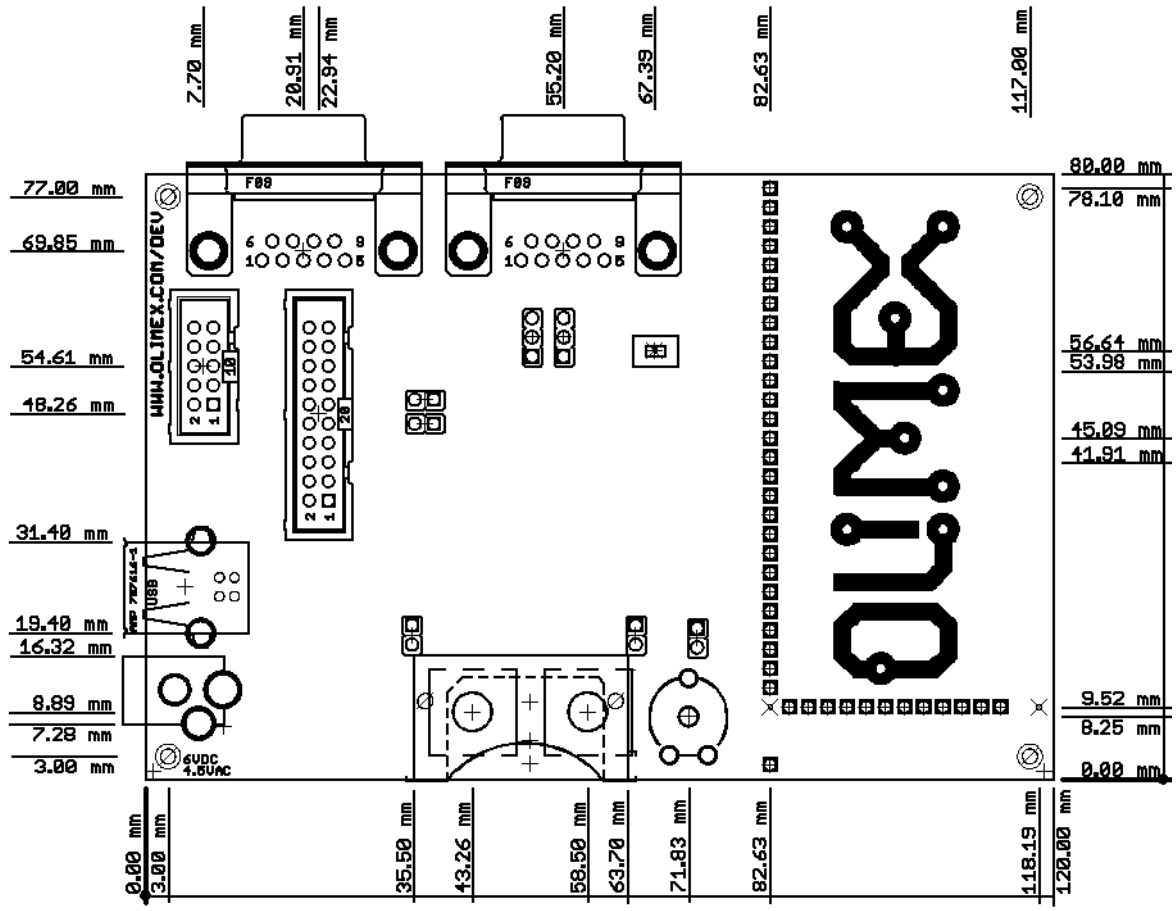

## **AVAILABLE DEMO SOFTWARE:**

The demo package available at the Software section of SAM3-P256's page features the following examples:

- Getting started – demonstrates use of LEDs, User buttons, Interrupts and Timers
- ADC demo – demonstrates use of analog peripherals on board
- SD card demo – demonstrates use of low level SD card routines
- USB demo – demonstrates use of USB device as a mouse

## **ORDER CODE:**

**SAM3-P256** - assembled and tested board

### **How to order?**

You can order directly from our web shop or purchase from any of our distributors.

The list of Olimex distributors might be found here:

<https://www.olimex.com/Distributors>

Check our web site <https://www.olimex.com/> for more info.

## **Revision history:**

Board's Revision:	Rev. Initial, July 2010
Manual's Revision	Rev. A, released May 2011
	Rev. B, released March 2013

## **DISCLAIMER**

© 2013 Olimex Ltd. Olimex®, logo and combinations thereof, are registered trademarks of Olimex Ltd. Other product names may be trademarks of others and the rights belong to their respective owners.

The information in this document is provided in connection with Olimex products. No license, express or implied or otherwise, to any intellectual property right is granted by this document or in connection with the sale of Olimex products.

The Hardware project is released under the Creative Commons Attribution-Share Alike 3.0 United States License. You may reproduce it for both your own personal use, and for commercial use. You will have to provide a link to the original creator of the project <https://www.olimex.com> on any documentation or website.

You may also modify the files, but you must then release them as well under the same terms. Credit can be attributed through a link to the creator website: <https://www.olimex.com>

The software is released under GPL.

It is possible that the pictures in this manual differ from the latest revision of the board.

The product described in this document is subject to continuous development and improvements. All particulars of the product and its use contained in this document are given by OLIMEX in good faith. However all warranties implied or expressed including but not limited to implied warranties of merchantability or fitness for purpose are excluded. This document is intended only to assist the reader in the use of the product. OLIMEX Ltd. shall not be liable for any loss or damage arising from the use of any information in this document or any error or omission in such information or any incorrect use of the product.

This evaluation board/kit is intended for use for engineering development, demonstration, or evaluation purposes only and is not considered by OLIMEX to be a finished end-product fit for general consumer use. Persons handling the product must have electronics training and observe good engineering practice standards. As such, the goods being provided are not intended to be complete in terms of required design-, marketing-, and/or manufacturing-related protective considerations, including product safety and environmental measures typically found in end products that incorporate such semiconductor components or circuit boards.

Olimex currently deals with a variety of customers for products, and therefore our arrangement with the user is not exclusive. Olimex assumes no liability for applications assistance, customer product design, software performance, or infringement of patents or services described herein.

**THERE IS NO WARRANTY FOR THE DESIGN MATERIALS AND THE COMPONENTS USED TO CREATE SAM3-P256. THEY ARE CONSIDERED SUITABLE ONLY FOR SAM3-P256.**