

## NPN Silicon Epitaxial Planar Transistor

### BC846W/BC847W/BC848W

#### FEATURES

- Low Current.
- Low voltage.
- Power dissipation.( $P_C=200\text{mW}$ )

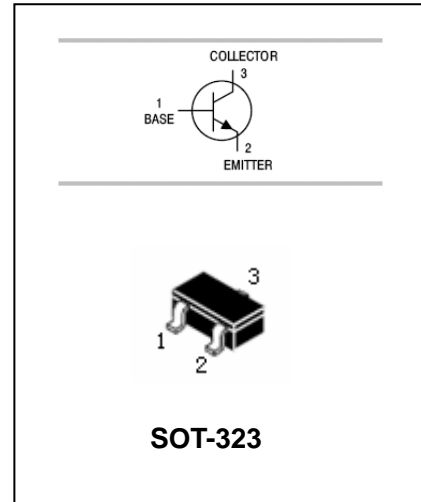

#### APPLICATIONS

- General purpose switching and amplification application.

#### ORDERING INFORMATION

Type No.	Marking	Package Code
BC846W	1A/1B	SOT-323
BC847W	1E/1F/1G	SOT-323
BC848W	1Js/1Ks/1Ls	SOT-323

#### MAXIMUM RATING @ $T_a=25^\circ\text{C}$ unless otherwise specified

Symbol	Parameter	Value	Units
$V_{CBO}$	Collector-Base Voltage	BC846W	80
		BC847W	50
		BC848W	30
$V_{CEO}$	Collector-Emitter Voltage	BC846W	65
		BC847W	45
		BC848W	30
$V_{EBO}$	Emitter-Base Voltage	BC846W,BC847W	6
		BC848W	5
$I_C$	Collector Current -Continuous	100	mA
$P_C$	Collector Dissipation	200	mW
$T_j, T_{stg}$	Junction and Storage Temperature	-65~150	$^\circ\text{C}$

## NPN Silicon Epitaxial Planar Transistor

### BC846W/BC847W/BC848W

#### ELECTRICAL CHARACTERISTICS @ Ta=25°C unless otherwise specified

Parameter	Symbol	Test conditions	MIN	TYP	MAX	UNIT
Collector-base breakdown voltage	$V_{(BR)CBO}$	$I_C=100\mu A, I_E=0$ BC846W	80			V
		BC847W	50			
		BC848W	30			
Collector-emitter breakdown voltage	$V_{(BR)CEO}$	$I_C=1mA, I_B=0$ BC846W	65			V
		BC847W	45			
		BC848W	30			
Emitter-base breakdown voltage	$V_{(BR)EBO}$	$I_E=100\mu A, I_C=0$ BC846W	6			V
		BC847W	6			
		BC848W	5			
Collector cut-off current	$I_{CBO}$	$V_{CB}=30V, I_E=0$			15	nA
Emitter cut-off current	$I_{EBO}$	$V_{EB}=5V, I_C=0$			100	nA
DC current gain	$h_{FE}$	$V_{CE}=5V, I_C=10\mu A$ BC846AW, BC847AW	90			
		BC846BW, BC847BW, BC848BW	150			
		BC847CW, BC848CW	270			
		$V_{CE}=2V, I_C=100mA$ BC846AW, BC847AW	110	180	220	
BC846BW, BC847BW, BC848BW	200	290	450			
BC847CW, BC848CW	420	520	800			
Collector-emitter saturation voltage	$V_{CE(sat)}$	$I_C=10mA, I_B=0.5mA$		90	250	mV
Base-emitter saturation voltage	$V_{BE(sat)}$	$I_C=10mA, I_B=0.5mA$		700		V
Transition frequency	$f_T$	$V_{CE}=5V, I_C=10mA, f=100MHz$	100			MHz
Collector capacitance	$C_C$	$V_{CB}=10V, I_E=0, f=1MHz$			3	pF

## NPN Silicon Epitaxial Planar Transistor

### BC846W/BC847W/BC848W

### PACKAGE OUTLINE

Plastic surface mounted package

SOT-323

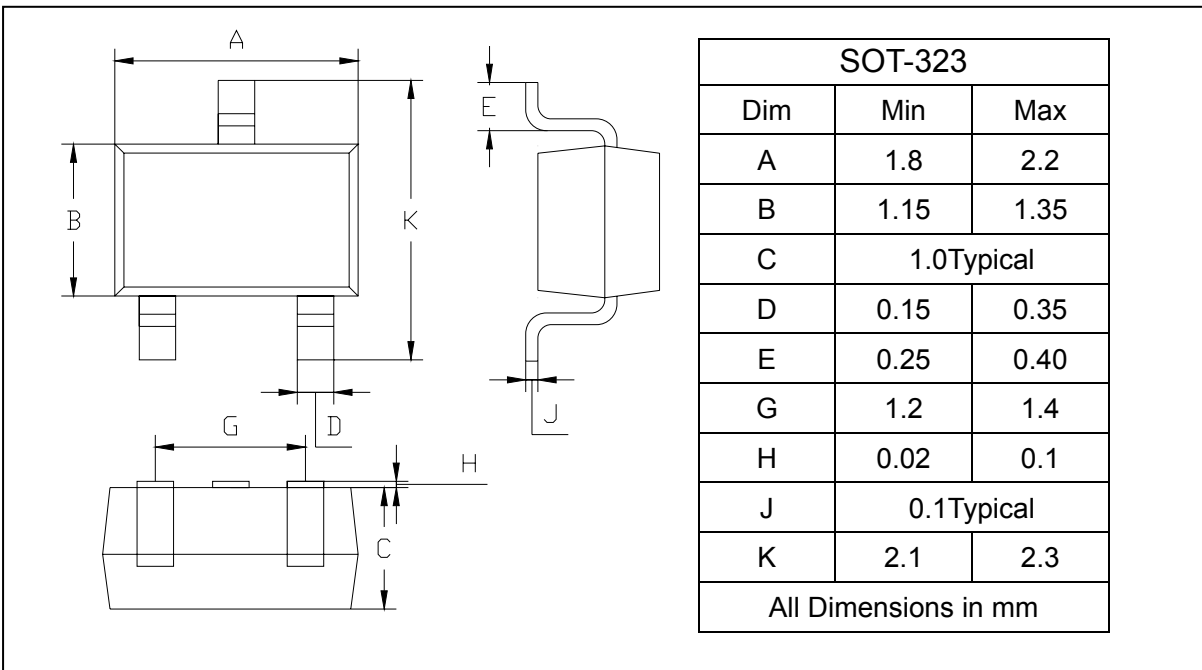

### SOLDERING FOOTPRINT

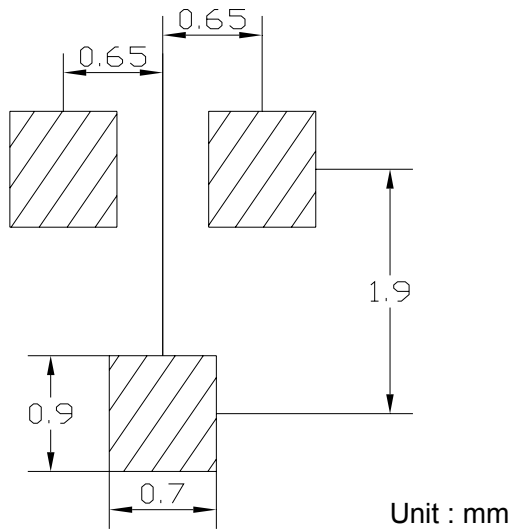

### PACKAGE INFORMATION

Device	Package	Shipping
BC846W/BC847W/BC848W	SOT-323	3000/Tape&Reel