

ZSPM4551

High-Efficiency Charger for Li-Ion Batteries

ZMDI[®]
The Analog Mixed Signal Company



Brief Description

The ZSPM4551 is a DC/DC synchronous switching lithium-ion (Li-Ion) battery charger with fully integrated power switches, internal compensation, and full fault protection.

Its switching frequency of 1MHz enables the use of small filter components, resulting in smaller board space and reduced BOM costs.

In Full-Charge Constant-Current Mode, the regulation is for constant current (CC). Once termination voltage is reached, the regulator operates in voltage mode. When the regulator is disabled (the EN pin is low), the device draws 10 μ A (typical) quiescent current.

The ZSPM4551 includes supervisory reporting through the NFLT (inverted fault) open-drain output to interface other components in the system. Device programming is achieved by an I²C™* interface through the SCL and SDA pins.

Benefits

- Up to 1.5A of continuous output current in Full-Charge Constant-Current (CC) Mode
- High efficiency – up to 92% with typical loads

Available Support

- Evaluation Kit
- Support Documentation

Features

- VBAT reverse-current blocking
- Programmable temperature-compensated termination voltage: 3.94V to 4.18V \pm 1%
- User programmable maximum charge current: 50mA to 1500mA
- Current mode PWM control in constant voltage
- Supervisor for VBAT reported at the NFLT pin
- Input supply under-voltage lockout
- Full protection for over-current, over-temperature, VBAT over-voltage, and charging timeout
- Charge status indication
- I²C™ program interface with EEPROM registers

Related ZMDI Smart Power Products

- ZSPM4121 Ultra-low Power Under-Voltage Switch
- ZSPM4141 Ultra-Low-Power Linear Regulator

Physical Characteristics

- Wide input voltage range: V_{BAT} + 0.3V (3.5V min.) to 7.2V
- Junction operating temperature: -40°C to 125°C
- Package: 16-pin PQFN (4mm x 4mm)

ZSPM4551 Application Circuit

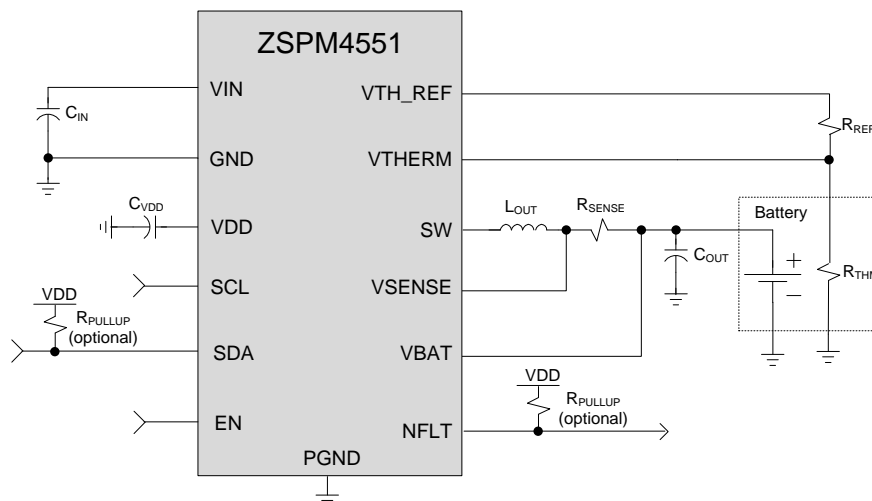

* I²C™ is a trademark of NXP.

For more information, contact ZMDI via Analog@zmdi.com.

ZSPM4551

High-Efficiency Charger for Li-Ion Batteries



ZSPM4551 Block Diagram

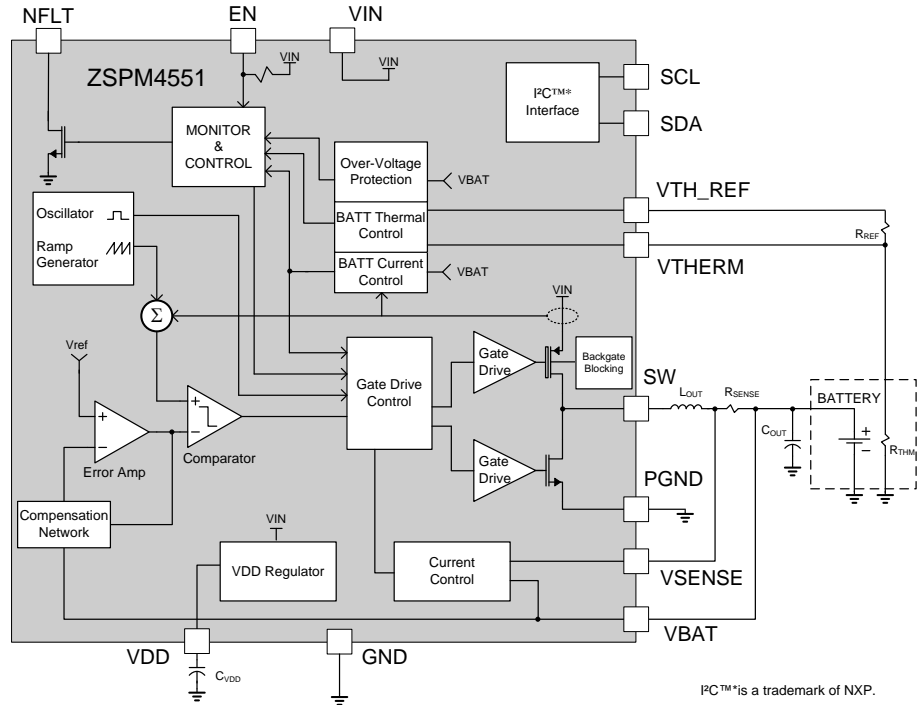

Typical Applications

- Portable battery chargers
- Smart phones
- Laptops
- Tablets/e-readers

Ordering Information

Ordering Code	Description	Package
ZSPM4551AA1W	ZSPM4551 High-Efficiency Li-Ion Battery Charger	16-pin PQFN / 7" Reel (1000 parts)
ZSPM4551AA1R	ZSPM4551 High-Efficiency Li-Ion Battery Charger	16-pin PQFN / 13" Reel (3300 parts)
ZSPM4551KIT	ZSPM4551 Evaluation Kit	

Sales and Further Information		www.zmdi.com	Analog@zmdi.com
Zentrum Mikroelektronik Dresden AG Grenzstrasse 28 01109 Dresden Germany Phone +49.351.8822.7.776 Fax +49.351.8822.8.7776	ZMD America, Inc. 1525 McCarthy Blvd., #212 Milpitas, CA 95035-7453 USA Phone +855.275.9634 (USA) Phone +408.883.6310 Fax +408.883.6358	Zentrum Mikroelektronik Dresden AG, Japan Office 2nd Floor, Shinbashi Tokyu Bldg. 4-21-3, Shinbashi, Minato-ku Tokyo, 105-0004 Japan Phone +81.3.6895.7410 Fax +81.3.6895.7301	ZMD Far East, Ltd. 3F, No. 51, Sec. 2, Keelung Road 11052 Taipei Taiwan Phone +886.2.2377.8189 Fax +886.2.2377.8199
			Zentrum Mikroelektronik Dresden AG, Korea Office U-space 1 Building 11th Floor, Unit JA-1102 670 Sampyeong-dong Bundang-gu, Seongnam-si Gyeonggi-do, 463-400 Korea Phone +82.31.950.7679 Fax +82.504.841.3026

DISCLAIMER: This information applies to a product under development. Its characteristics and specifications are subject to change without notice. Zentrum Mikroelektronik Dresden AG (ZMD AG) assumes no obligation regarding future manufacture unless otherwise agreed to in writing. The information furnished hereby is believed to be true and accurate. However, under no circumstances shall ZMD AG be liable to any customer, licensee, or any other third party for any special, indirect, incidental, or consequential damages of any kind or nature whatsoever arising out of or in any way related to the furnishing, performance, or use of this technical data. ZMD AG hereby expressly disclaims any liability of ZMD AG to any customer, licensee or any other third party, and any such customer, licensee and any other third party hereby waives any liability of ZMD AG for any damages in connection with or arising out of the furnishing, performance or use of this technical data, whether based on contract, warranty, tort (including negligence), strict liability, or otherwise.