

Part Number : **CM1822**

Type	Size	Rating	Description
Incandescent	T10	36V 100mA	T-3¼ Miniature Bayonet lamp

Dimensions(mm):

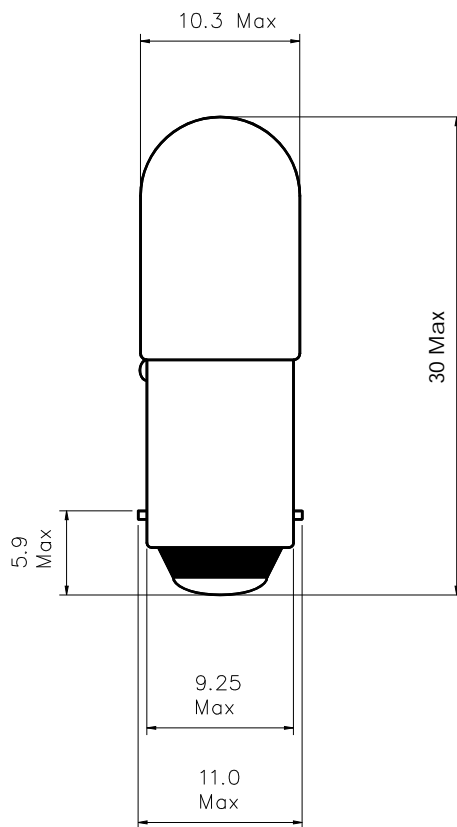

TEST VOLTS	CURRENT (mA)			LIGHT OUTPUT (Lm)			LIFE Hours
	Min.	Nom.	Max.	Min.	Nom.	Max.	
36	90	100	110	19.8	26.4	33.0	1,000

Notes:

- 1 Lamp base BA9s/13 in accordance with IEC61-1, (BS EN 60061-1) sheet 7004-14-x.
- 2 Lamp marking **CML1822 36V 100mA**
- 3 Filament shape C-2F
- 4 Bead colour: White or Clear
- 5 RoHS and REACH SVHC compliant

Issue # 1 : 11June13