

SANMOTION

2-PHASE STEPPING SYSTEMS

F2

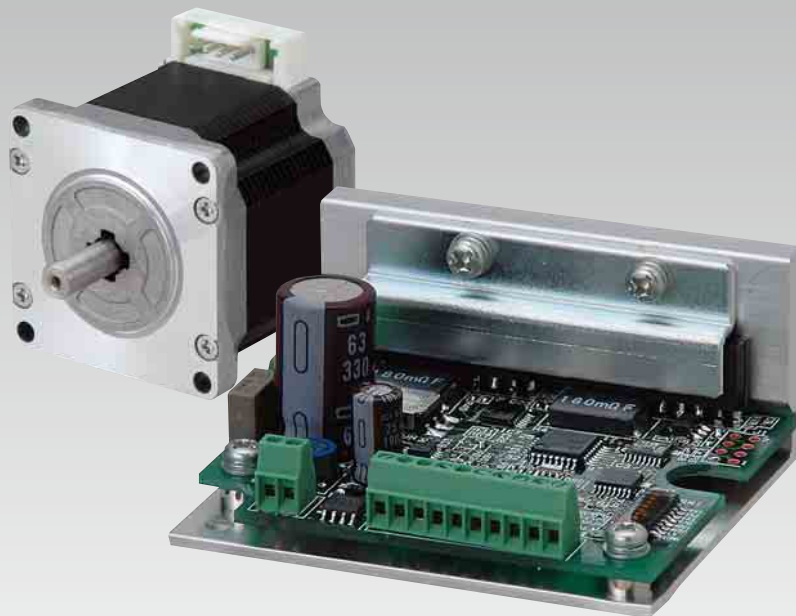

Ver.4

SANYO DENKI

SANMOTION

2-PHASE STEPPING SYSTEMS

F2



DC input set model



DC input driver



Stepping Motor

Motor size: 14mm sq. (0.55inch sq.) to
86mm sq. (3.39inch sq.), ϕ 106mm (ϕ 4.17inch)



Stepping motors with integrated drivers ·
Stepping motor for vacuum environment

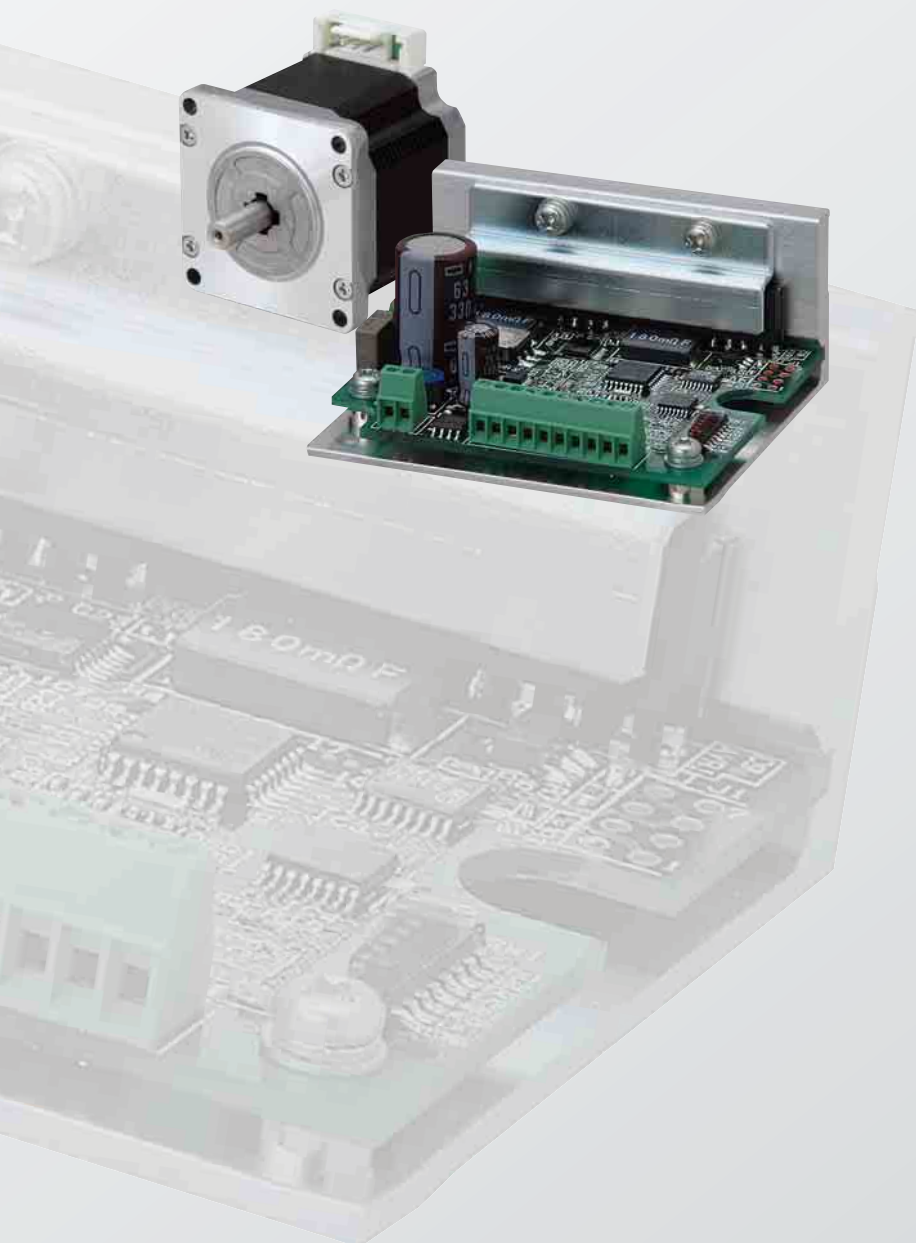

Contents

Features	P.4
Line up	P.5
Lineup Details	P.6
DC input set model	P.8
System configuration diagram	P.8
Set model numbering convention	P.9
Set Model Configuration	P.10
Unipolar models specifications	P.11
Bipolar models specifications	P.14
Driver specifications	P.19
Driver Controls and Connectors	P.20
Connections and Signals	P.21
Stepping Motor	P.24
Stepping motors with integrated drivers ..	P.55
Stepping motor for vacuum environment ..	P.63
Dimensions	P.64
Safety Consideration	P.71

SANMOTION F2

2-PHASE STEPPING SYSTEMS

SANMOTION F2 is a 2-phase stepping system that provides precise positioning with simple control. The typical basic step angle is 1.8°, with accurate control by pulse signals.

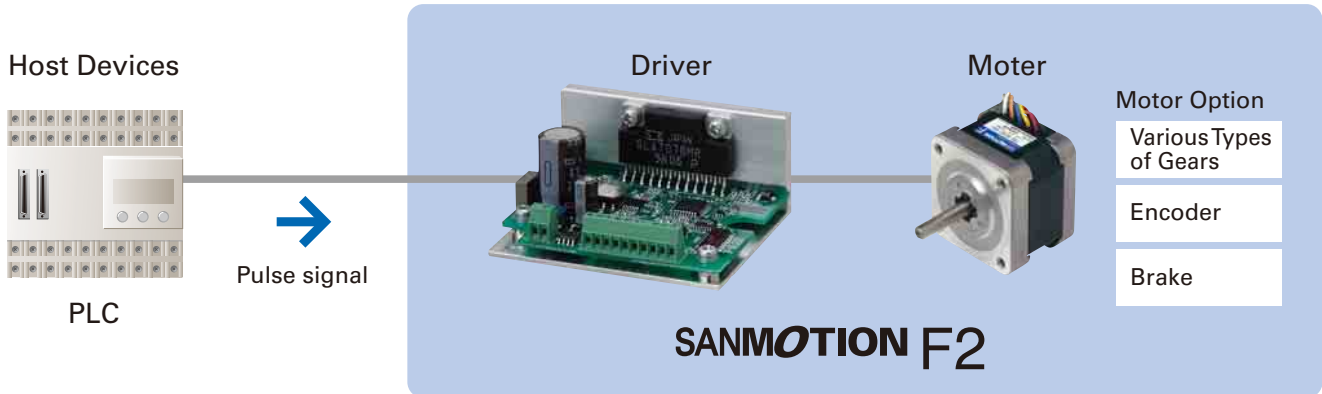

Features

- Small driver and motor, yet high torque.
- Fast response provides shorter system cycletime for repetitive operations.
- Holding torque maintains the stop position when turning on power.
- Low-vibration mode

Smooth driving is achieved even with one-division (full-step) and two-division (half-step) coarse resolution settings. Vibration is suppressed without control system restrictions.

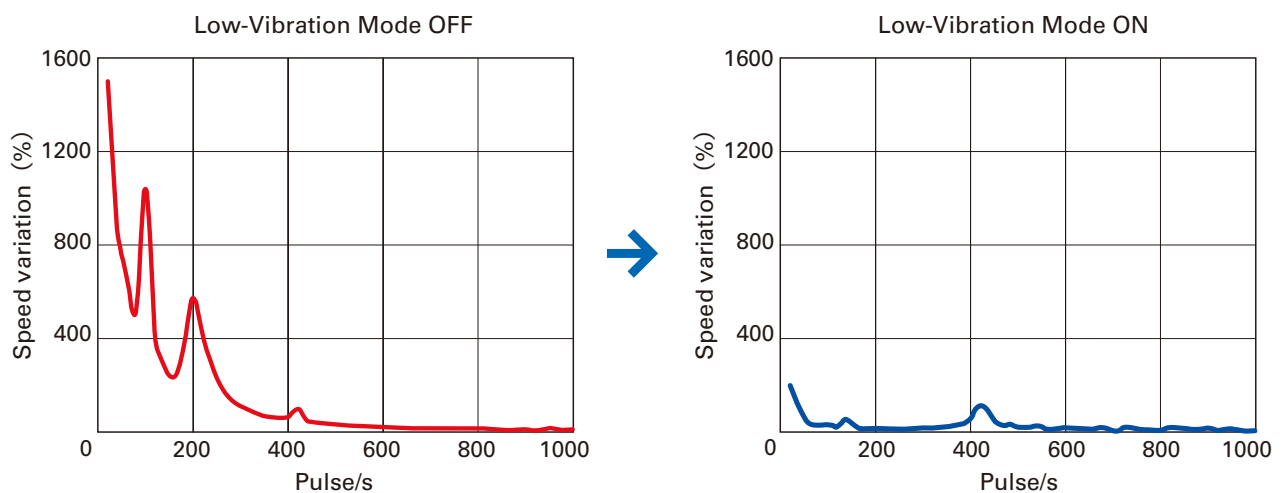

- Micro-step driving system

Five 1.8° basic step angle resolutions can be selected from 1 to 16 divisions (1.8° to 0.1125° per pulse). Enables a smooth operation with low vibration.

Safety standards

The SANMOTION F2 drive complies with CE (EN standards) and UL standard specifications.



Line up

Convenient set models consist of a DC-powered driver and motor.

Beside the set models, only stepping motors can be selected.

The lineup also includes stepping motors with built-in drivers, and stepping motors for vacuum environments.

Set model

DC input

Unipolar

These set models consist of a DC-powered driver and motor.
The motor winding specification is unipolar.

Motor size:
28mm sq. (1.10inch sq.) / 42mm sq. (1.65inch sq.) / 56mm sq.(2.20inch sq.)



Bipolar

These set models consist of a DC-powered driver and motor.
The motor winding specification is bipolar.

Motor size:
28mm sq. (1.10inch sq.) / 42mm sq.(1.65inch sq.) / 50mm sq (1.97inch sq.) /
56mm sq. (2.20inch sq.) / 60mm sq. (2.36inch sq.)

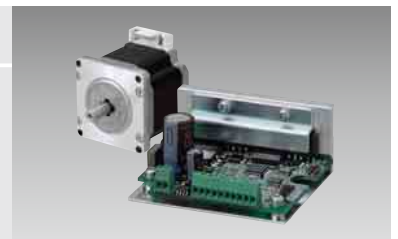

Stepping Motor

This is a high-torque stepping motor. Select from a broad lineup of products with ultra-compact 14 mm sq. (0.55 in sq.) motor size, or a thin 11.4 mm (0.45 in) motor - the shortest motor length.

A separate driver is required.

Motor size:
14mm sq. (0.55inch sq.) / 28mm sq. (1.10inch sq.) /
35mm sq. (1.38inch sq.) / 42mm sq. (1.65inch sq.) /
50mm sq. (1.97inch sq.) / 56mm sq. (2.20inch sq.) /
60mm sq. (2.36inch sq.) / 86mm sq.
(3.39inch sq., CE and UL models are available.) /
ø 106mm (ø 4.17inch)



Stepping motors with integrated drivers

These include integrated drivers. They reduce mounting space requirements and wiring complexity. Operating modes are selectable from pulse train control, and control by general-purpose I/O (parallel interface) or by RS-485 compliant serial communications.

Motor size:
42mm sq. (1.65inch sq.) /
60mm sq. (2.36inch sq.)



Stepping motor for vacuum environment Customized Products

"We customize motors for use in low to ultra-high vacuum environments to suit your system requirements.

A separate driver is required.



Lineup Details

Set model Page P.8 ~

Series		DC input set model Unipolar	DC input set model Bipolar
Input source		DC 24V/36V	DC 24V/36V
Number of divisions		1, 2, 4, 8, 16	1, 2, 4, 8, 16
Step-angle	Motors with 1.8° basic step angle	1.8° to 0.1125° /pulse	1.8° to 0.1125° /pulse
	Motors with 0.9° basic step angle	0.9° to 0.05625° /pulse	0.9° to 0.05625° /pulse
Corresponding motor sizes		28mm sq. (1.10inch sq.) / 42mm sq. (1.65inch sq.) / 56mm sq. (2.20inch sq.)	28mm sq. (1.10inch sq.) / 42mm sq. (1.65inch sq.) / 50mm sq. (1.97inch sq.) / 56mm sq. (2.20inch sq.) / 60mm sq. (2.36inch sq.)
Control method		Pulse input · Open loop	Pulse input · Open loop
Set model accessories		Driver, Motor, Cable with Connector (Supplied only with connector-type motors)	Driver, Motor, Cable with Connector (Supplied only with connector-type motors)
Page	System configuration diagram	P.8	P.8
	Set model configuration diagram	P.10	P.10
	Specifications / Characteristics drawing	P.11 to 13	P.14 to 18
	Driver specifications / Safety standards	P.19	P.19
	Motor Specifications	P.54	P.54
	Dimensions	P.64 to 70	P.64 to 70

Stepping Motor Page P24 ~

Basic step angle	Motor size	Holding torque N · m (oz · in)	Model number	Page	
				Specifications / Characteristics drawing	Dimensions
0.9°	42mm sq. (1.65inch sq.)	0.2 to 0.48 (28.3 to 68.0)	SH142 □ - □□□ 1	P.29 to 30	P.65
0.9°	60mm sq. (2.36inch sq.)	0.57 to 2.15 (80.7 to 304)	SH160 □ - □□□ 0	P.42 to 43	P.66
1.8°	14mm sq. (0.55inch sq.)	0.0065 (0.92)	SH2141-55 □ 1	P.24	P.64
1.8°	28mm sq. (1.10inch sq.)	0.055 to 0.145 (7.79 to 20.5)	SH228 □ -5 □□ 1	P.25 to 26	P.64
1.8°	35mm sq. (1.38inch sq.)	0.12 to 0.23 (17.0 to 32.6)	SH35 □□ -12U □ 0	P.27	P.64
1.8°	42mm sq. (1.65inch sq.) Slim form	0.083 to 0.186 (11.8 to 26.3)	SS242 □ -50 □ 1	P.28	P.64
1.8°	42mm sq. (1.65inch sq.)	0.2 to 0.51 (28.3 to 72.2)	103H52 □□ - □□□ 0	P.31 to 33	P.64 to 65
1.8°	50mm sq. (1.97inch sq.)	0.28 to 0.53 (39.7 to 75.1)	103H670 □ - □□□ 0	P.34 to 36	P.65
1.8°	50mm sq. (1.97inch sq.) Slim form	0.1 to 0.215 (14.2 to 30.4)	SS250 □ -80 □ 0	P.37	P.65
1.8°	56mm sq. (2.20inch sq.)	0.39 to 2.0 (55.2 to 283)	103H712 □ - □□□ 0	P.38 to 41	P.66
1.8°	60mm sq. (2.36inch sq.)	0.78 to 2.7 (110 to 382)	103H782 □ - □□□ 0	P.44 to 47	P.67
1.8°	86mm sq. (3.39inch sq., CE and UL models are available.)	2.5 to 9 (358 to 1270)	SH286 □ - □□□ 1 SM286 □ - □□□□	P.48 to 51	P.68 to 69
1.8°	φ106mm (φ4.17inch)	10.8 to 19 (1530 to 2690)	103H8922 □ - □□□ 1	P.52	P.69

• Contact us for available encoders, gears and motors with brakes.

Stepping motors with integrated drivers Page P55 ~

Motor size	Input source	Interfaces	Model number	Page	
				Specifications / Characteristics drawing	Dimensions
42mm sq. (1.65inch sq.)	DC24V	<ul style="list-style-type: none"> Pulse input General-purpose I/O(Parallel) Serial communication (compliant with RS-485) 	DB21M142S-01	P.56	P.70
60mm sq. (1.65inch sq.)			DB22M162S-01	P.56	P.70

Stepping motor for vacuum environment Page P63

We customize motors for use in low to ultra-high vacuum environments to suit your system requirements.
We can handle a wide range of pressures for low, high and ultra-high vacuums.

DC input set model

Unipolar • Bipolar

Set Model Configuration ▶ P.10
 Specifications / Characteristics drawings ▶ P.11 to 18
 Motor Specifications ▶ P.54 Driver specifications ▶ P.19
 Motor dimensions ▶ P.64 to 67
 Driver dimensions ▶ P.70



Features

- These are convenient sets of DC-powered drivers and motors.
- Select from two types of set models: with either unipolar or bipolar motor windings."

Set model configuration items

Driver



Unipolar Model number : US1D200P10 Input source : DC24V/36V

Bipolar Model number : BS1D200P10 Input source : DC24V/36V

Motor

Unipolar Motor size: 28mm sq. (1.10inch sq.), 42mm sq. (1.65inch sq.), 56mm sq. (2.20inch sq.)

Bipolar Motor size: 28mm sq. (1.10inch sq.), 42mm sq. (1.65inch sq.), 50mm sq. (1.97inch sq.), 56mm sq. (2.20inch sq.), 60mm sq. (2.36inch sq.)

Cable with connector

*Supplied only with connector-type motors

- Download instruction manuals from our website.

System configuration diagram

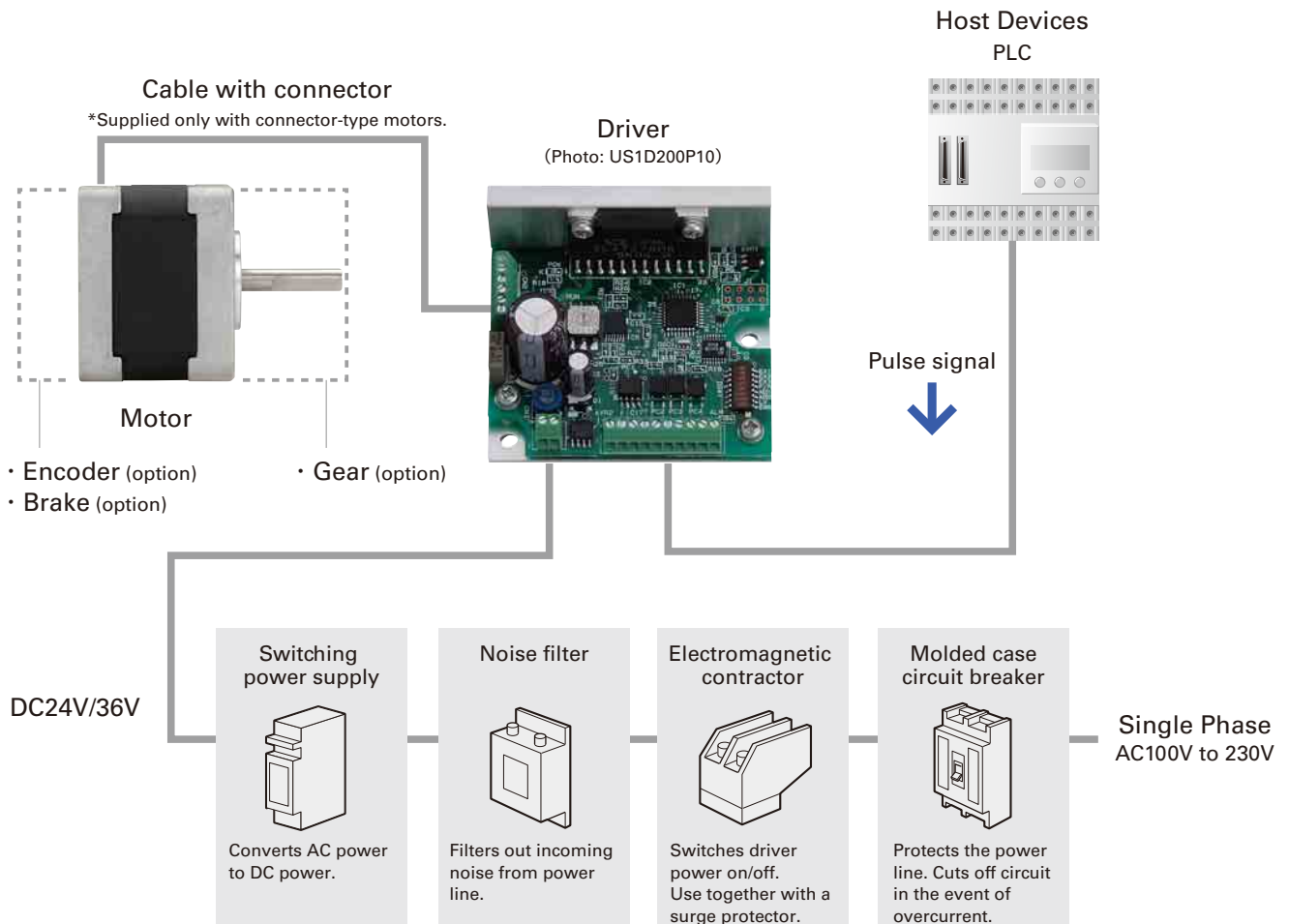

Set model numbering convention

Here is the set model number for a DC-powered unipolar driver (Model No. US1D200P10) and motor (Model No. 103H7121-0440). Motor size is 56 mm sq. (2.20 in sq.), and motor length is 41.8 mm (1.65 in.), single-shaft.

D U 1 6 H 71 1 S

Stepping motor shaft spec
 S : Single shaft
 D : Double shafts

Stepping motor total length

Code	Stepping motor size													
	28mm sq. (1.10inch sq.)		42mm sq. (1.65inch sq.)				50mm sq. (1.97inch sq.)		56mm sq. (2.20inch sq.)		60mm sq. (2.36inch sq.)			
	Type code	Motor length : mm (inch)	Type code	Motor length : mm (inch)	Type code	Motor length : mm (inch)	Type code	Motor length : mm (inch)	Type code	Motor length : mm (inch)	Type code	Motor length : mm (inch)	Type code	Motor length : mm (inch)
1	SH2281	32 (1.26)	103H5205	33 (1.30)	SH1421	33 (1.30)	103H6701	39.8 (1.57)	103H7121	41.8 (1.65)	103H7821	44.8 (1.76)	SH1601	42 (1.65)
2			103H5208	39 (1.54)	SH1422	39 (1.54)					103H7822	53.8 (2.12)	SH1602	54 (2.12)
3							103H6703	51.3 (2.02)	103H7123	53.8 (2.12)	103H7823	86.8 (3.38)		
4			103H5210	48 (1.89)	SH1424	48 (1.89)								
5	SH2285	51.5 (2.03)												
6									103H7126	75.8 (2.89)				

Stepping motor size	Basic step angle
28 : 28mm sq. (1.10inch sq.)	1.8°
52 : 42mm sq. (1.65inch sq.)	1.8°
14 : 42mm sq. (1.65inch sq.)	0.9°
67 : 50mm sq. (1.97inch sq.)	1.8°
71 : 56mm sq. (2.20inch sq.)	1.8°
78 : 60mm sq. (2.36inch sq.)	1.8°
16 : 60mm sq. (2.36inch sq.)	0.9°

Stepping motor series name
 H : H series
 S : SH series

Rated current specification
 4 : 1A/phase 5 : 1.2A/phase 6 : 2A/phase

Model

Driver Specification
 U : Unipolar B : Bipolar

D : DC input

Set Model Configuration This is a set comprising a driver, motor and cable with motor connector.

Unipolar Bundled driver model number : US1D200P10

Motor size	Single shaft			Double shafts			Basic step angle	Rated current (A/phase)	Page	
	Set model number	Set configuration items		Set model number	Set configuration items				Specifi- cations	Dimen- sions
		Motor model number	Cable with motor connector model number		Motor model number	Cable with motor connector model number				
28 mm sq.	DU14S281S	SH2281-5271	—	DU14S281D	SH2281-5231	—	1.8°	1	P.11	P.64
	DU14S285S	SH2285-5271	—	DU14S285D	SH2285-5231	—	1.8°	1	P.11	P.64
42 mm sq.	DU15H521S	103H5205-0440	4835710-1	DU15H521D	103H5205-0410	4835710-1	1.8°	1.2	P.11	P.64
	DU15H522S	103H5208-0440	4835710-1	DU15H522D	103H5208-0410	4835710-1	1.8°	1.2	P.11	P.64
	DU15H524S	103H5210-0440	4835710-1	DU15H524D	103H5210-0410	4835710-1	1.8°	1.2	P.12	P.64
	DU15S141S	SH1421-0441	—	DU15S141D	SH1421-0411	—	0.9°	1.2	P.12	P.65
	DU15S142S	SH1422-0441	—	DU15S142D	SH1422-0411	—	0.9°	1.2	P.12	P.65
	DU15S144S	SH1424-0441	—	DU15S144D	SH1424-0411	—	0.9°	1.2	P.12	P.65
56 mm sq.	DU16H711S	103H7121-0440	—	DU16H711D	103H7121-0410	—	1.8°	2	P.13	P.66
	DU16H713S	103H7123-0440	—	DU16H713D	103H7123-0410	—	1.8°	2	P.13	P.66
	DU16H716S	103H7126-0440	—	DU16H716D	103H7126-0410	—	1.8°	2	P.13	P.66

● Cable with motor connector *Supplied only with connector-type motors

Bundled cable(Unipolar 42mm sq. (1.65inch sq.) motors only, model number: 4835710-1)

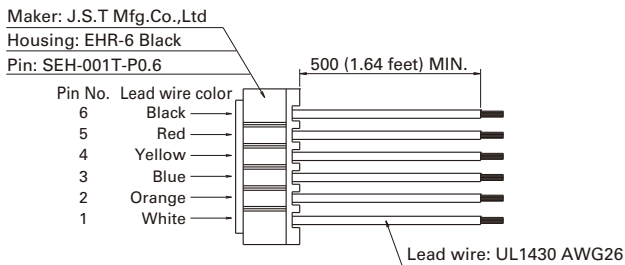

Bipolar Bundled driver model number : BS1D200P10

Motor size	Single shaft			Double shafts			Basic step angle	Rated current (A/phase)	Page	
	Set model number	Set configuration items		Set model number	Set configuration items				Specifi- cations	Dimen- sions
		Motor model number	Cable with motor connector model number		Motor model number	Cable with motor connector model number				
28 mm sq.	DB14S281S	SH2281-5771	—	DB14S281D	SH2281-5731	—	1.8°	1	P.14	P.64
	DB14S285S	SH2285-5771	—	DB14S285D	SH2285-5731	—	1.8°	1	P.14	P.64
42 mm sq.	DB14H521S	103H5205-5240	—	DB14H521D	103H5205-5210	—	1.8°	1	P.14	P.65
	DB14H522S	103H5208-5240	—	DB14H522D	103H5208-5210	—	1.8°	1	P.14	P.65
	DB14H524S	103H5210-5240	—	DB14H524D	103H5210-5210	—	1.8°	1	P.15	P.65
	DB16S141S	SH1421-5241	—	DB16S141D	SH1421-5211	—	0.9°	2	P.15	P.65
	DB16S142S	SH1422-5241	—	DB16S142D	SH1422-5211	—	0.9°	2	P.15	P.65
	DB16S144S	SH1424-5241	—	DB16S144D	SH1424-5211	—	0.9°	2	P.15	P.65
50 mm sq.	DB16H671S	103H6701-5040	—	DB16H671D	103H6701-5010	—	1.8°	2	P.16	P.65
	DB16H673S	103H6703-5040	—	DB16H673D	103H6703-5010	—	1.8°	2	P.16	P.65
56 mm sq.	DB16H711S	103H7121-5740	—	DB16H711D	103H7121-5710	—	1.8°	2	P.16	P.66
	DB16H713S	103H7123-5740	—	DB16H713D	103H7123-5710	—	1.8°	2	P.16	P.66
	DB16H716S	103H7126-5740	—	DB16H716D	103H7126-5710	—	1.8°	2	P.17	P.66
60 mm sq.	DB16H781S	103H7821-5740	4837961-1	DB16H781D	103H7821-5710	4837961-1	1.8°	2	P.17	P.67
	DB16H782S	103H7822-5740	4837961-1	DB16H782D	103H7822-5710	4837961-1	1.8°	2	P.17	P.67
	DB16H783S	103H7823-5740	4837961-1	DB16H783D	103H7823-5710	4837961-1	1.8°	2	P.17	P.67
	DB16S161S	SH1601-5240	—	DB16S161D	SH1601-5210	—	0.9°	2	P.18	P.66
	DB16S162S	SH1602-5240	—	DB16S162D	SH1602-5210	—	0.9°	2	P.18	P.66

● Cable with motor connector *Supplied only with connector-type motors

Bundled cable (Bipolar 60 mm sq. (2.36inch sq.) motors only, model number: 4837961-1)

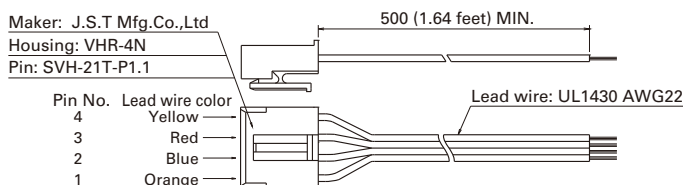

Unipolar DC input driver (Model No.: US1D200P10) + Motor

Size	Motor size	28mm sq. (1.10inch sq.) / Basic step angle 1.8°		42mm sq. (1.65inch sq.) / Basic step angle 1.8°	
	Motor length	32mm (1.26inch)	51.5mm (2.03inch)	33mm (1.30inch)	39mm (1.89inch)
Single shaft	Set model number	DU14S281S	DU14S285S	DU15H521S	DU15H522S
	Configuration item: motor number	SH2281-5271	SH2285-5271	103H5205-0440	103H5208-0440
Double shaft	Set model number	DU14S281D	DU14S285D	DU15H521D	DU15H522D
	Configuration item: motor number	SH2281-5231	SH2285-5231	103H5205-0410	103H5208-0410
Holding torque	N · m (oz · in)	0.055 (7.79)	0.115 (16.28)	0.2 (28.32)	0.3 (42.48)
Rotor inertia	$\times 10^{-4}$ kg · m ² (oz · in ²)	0.01 (0.05)	0.022 (0.12)	0.036 (0.20)	0.056 (0.31)
Rated current	A/phase	1	1	1.2	1.2
Motor mass ^(Note 1)	kg (lbs)	0.11 (0.24)	0.2 (0.44)	0.23 (0.51)	0.29 (0.64)
Allowable thrust load	N (lbs)	3 (0.67)	3 (0.67)	10 (2.25)	10 (2.25)
Allowable radial load ^(Note 2)	N (lbs)	42 (9.44)	49 (11.02)	30 (6)	30 (6)

(Note 1) Driver mass ▶ P.19

(Note2) When load is applied at 1/3 length from output shaft edge.

Characteristic drawing

With rubber coupling

Pull-out torque — Full step — Half step — fs: Maximum self-start frequency when not loaded
 Source current (no load) — Full step — Half step — Source current (load applied) — Full step — Half step

DU14S281S
DU14S281D

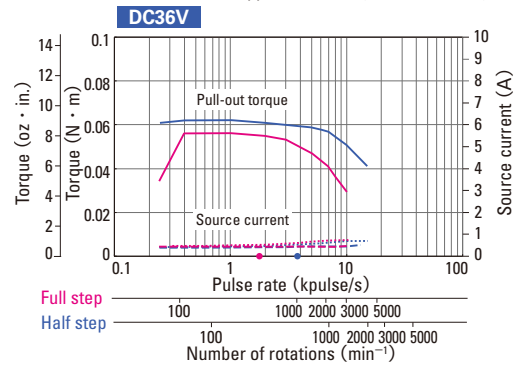
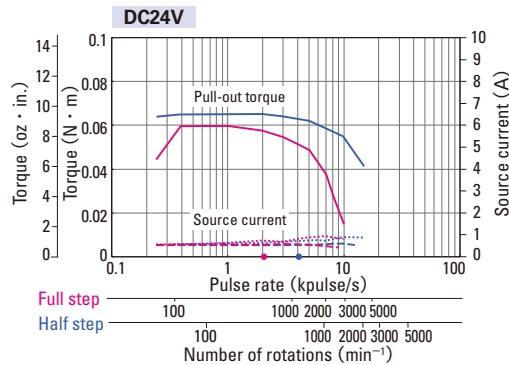

DU14S285S
DU14S285D

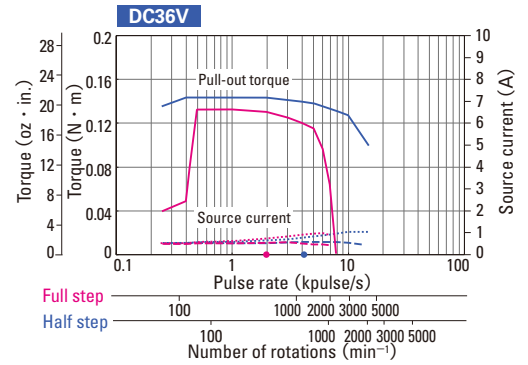
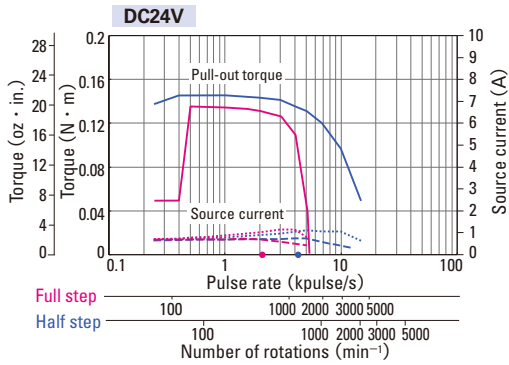

DU15H521S
DU15H521D

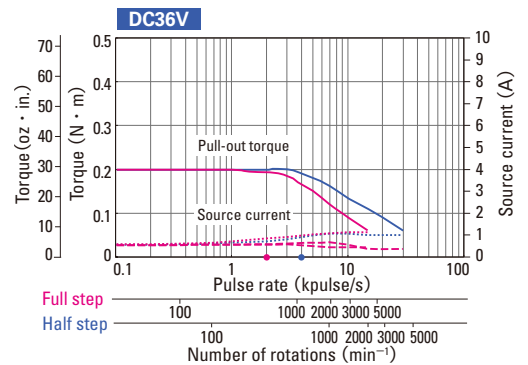
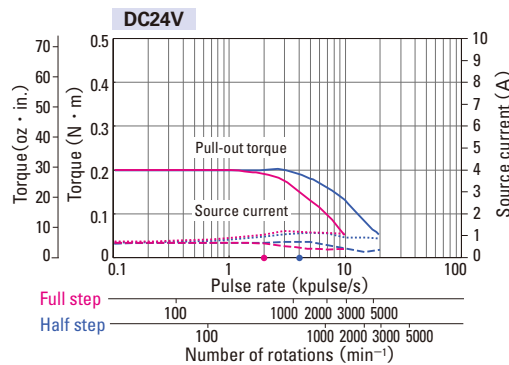

DU15H522S
DU15H522D

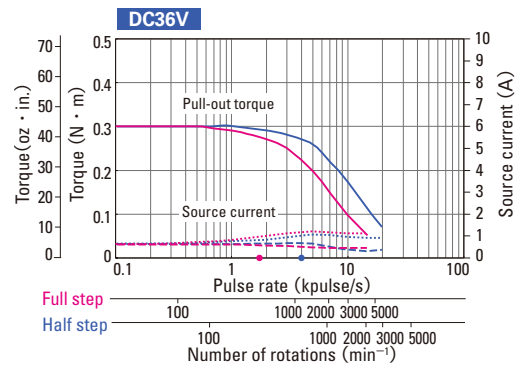
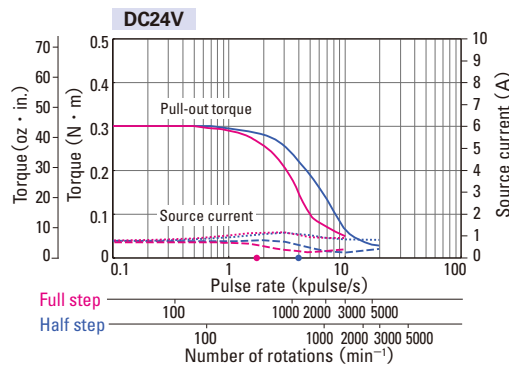

System configuration diagram ▶ P.8 Set Model Configuration ▶ P.10 Motor dimensions ▶ P.64 to 67 Driver dimensions ▶ P.70
 The data are measured under the drive condition of our company. Driving torque may vary according to actual machine precision.

Unipolar DC input driver (Model No.: US1D200P10) + Motor

Size	Motor size	42mm sq. (1.65inch sq.) / Basic step angle 1.8°			
	Motor length	48mm (1.89inch)	33mm (1.30inch)	39mm (1.54inch)	48mm (1.89inch)
Single shaft	Set model number	DU15H524S	DU15S141S	DU15S142S	DU15S144S
	Configuration item: motor number	103H5210-0440	SH1421-0441	SH1422-0441	SH1424-0441
Double shaft	Set model number	DU15H524D	DU15S141D	DU15S142D	DU15S144D
	Configuration item: motor number	103H5210-0410	SH1421-0411	SH1422-0411	SH1424-0411
Holding torque	N · m (oz · in)	0.37 (52.39)	0.2 (28.32)	0.29 (41.07)	0.39 (55.23)
Rotor inertia	$\times 10^{-4}$ kg · m ² (oz · in ²)	0.074 (0.40)	0.044 (0.24)	0.066 (0.361)	0.089 (0.487)
Rated current	A/phase	1.2	1.2	1.2	1.2
Motor mass ^(Note 1)	kg (lbs)	0.37 (0.82)	0.24 (0.53)	0.29 (0.64)	0.38 (0.84)
Allowable thrust load	N (lbs)	10 (2.25)	10 (2.25)	10 (2.25)	10 (2.25)
Allowable radial load ^(Note 2)	N (lbs)	30 (6)	30 (6)	30 (6)	30 (6)

(Note 1) Driver mass ▶ P.19

(Note2) When load is applied at 1/3 length from output shaft edge.

Characteristic drawing

With rubber coupling

Pull-out torque Source current (no load) Full step Half step fs : Maximum self-start frequency when not loaded Full step Half step
 Source current (load applied) Full step Half step

DU15H524S
DU15H524D

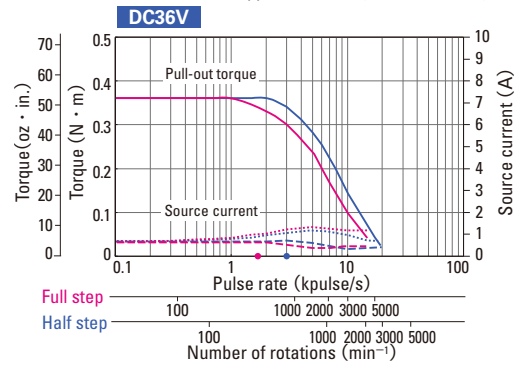
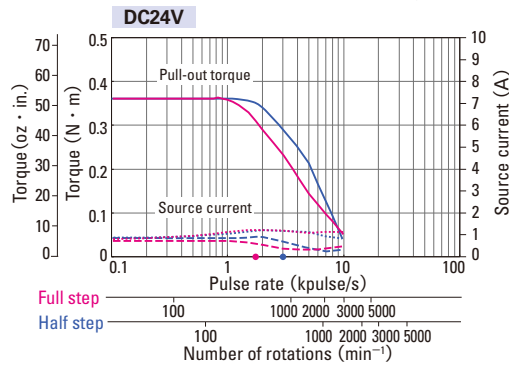

DU15S141S
DU15S141D

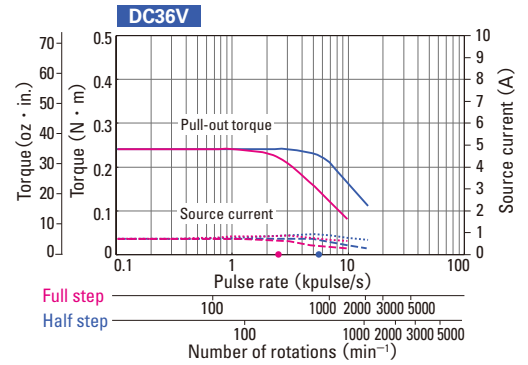
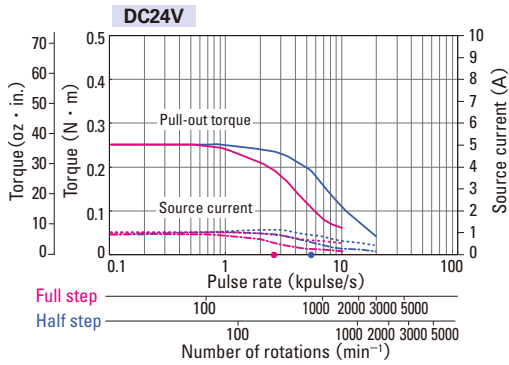

DU15S142S
DU15S142D

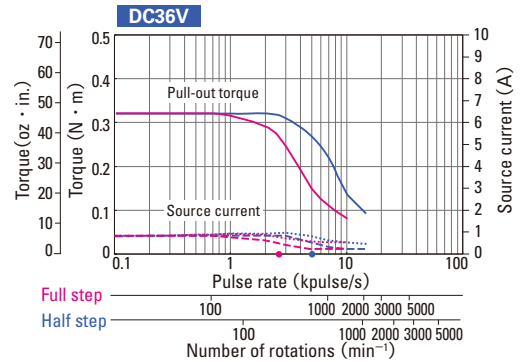
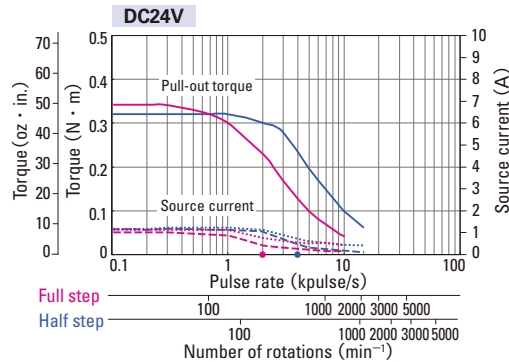

DU15S144S
DU15S144D

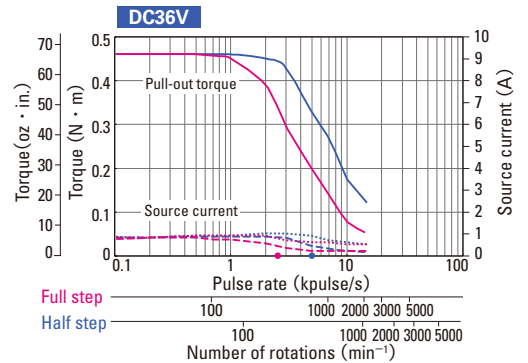
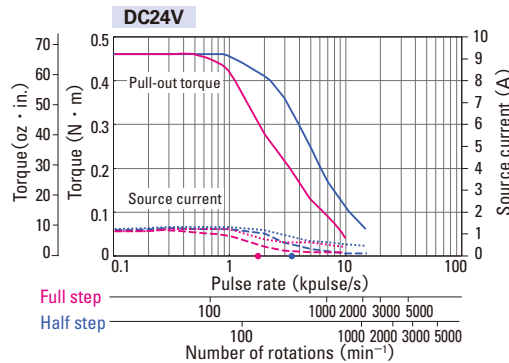

System configuration diagram ▶ P.8 Set Model Configuration ▶ P.10 Motor dimensions ▶ P.64 to 67 Driver dimensions ▶ P.70
 The data are measured under the drive condition of our company. Driving torque may vary according to actual machine precision.

Size		56mm sq. (2.20inch sq.) / Basic step angle 1.8°		
		41.8mm (1.65inch)	53.8mm (2.12inch)	75.8mm (2.98inch)
Single shaft	Motor size			
	Motor length			
Set model number	DU16H711S	DU16H713S	DU16H716S	
	Configuration item: motor number	103H7121-0440	103H7123-0440	103H7126-0440
Set model number	DU16H711D	DU16H713D	DU16H716D	
	Configuration item: motor number	103H7121-0410	103H7123-0410	103H7126-0410
Holding torque	N · m (oz · in)	0.39 (55.23)	0.83 (117.5)	1.27 (179.8)
Rotor inertia	$\times 10^{-4} \text{kg} \cdot \text{m}^2$ (oz · in ²)	0.1 (0.55)	0.21 (1.15)	0.36 (1.97)
Rated current	A/phase	2	2	2
Motor mass ^(Note 1)	kg (lbs)	0.47 (1.04)	0.65 (1.43)	0.98 (2.16)
Allowable thrust load	N (lbs)	15 (3.37)	15 (3.37)	15 (3.37)
Allowable radial load ^(Note 2)	N (lbs)	71 (15)	71 (15)	71 (15)

(Note 1) Driver mass ▶ P.19
 (Note2) When load is applied at 1/3 length from output shaft edge.

Characteristic drawing

With rubber coupling

Pull-out torque Full step — Half step — fs : Maximum self-start frequency when not loaded Full step ● Half step ●
 Source current (no load) Full step - - - Half step - - - Source current (load applied) Full step ····· Half step ·····

DU16H711S
DU16H711D

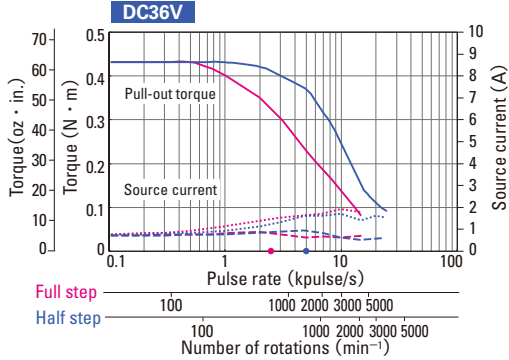
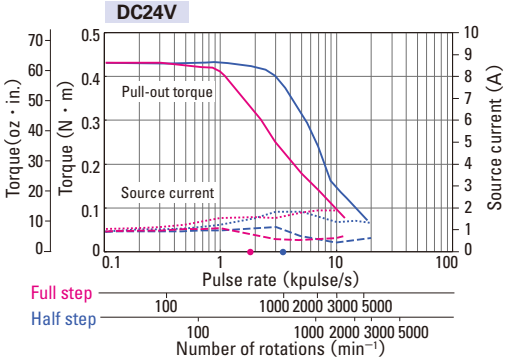

DU16H713S
DU16H713D

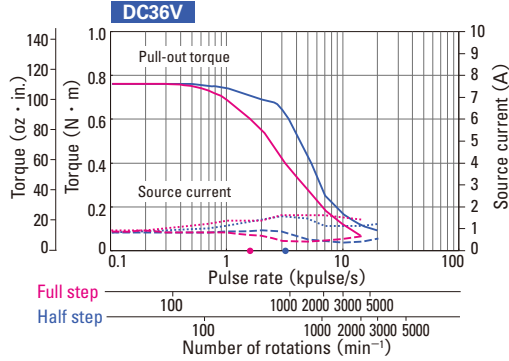
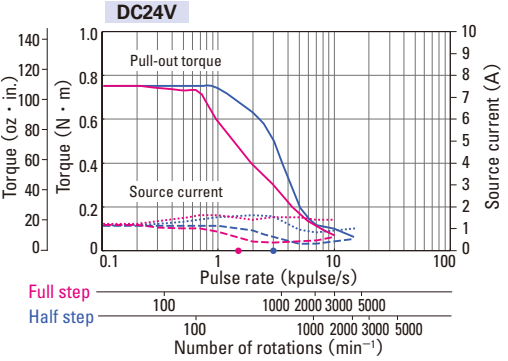

DU16H716S
DU16H716D

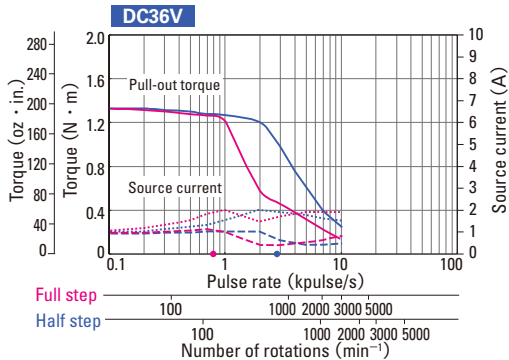
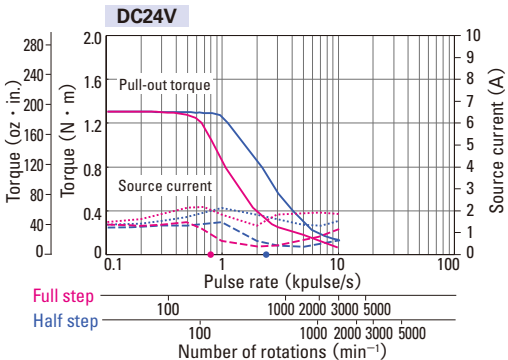

Bipolar DC input driver (Model No.: BS1D200P10) + Motor

Size	Motor size	28mm sq. (1.10inch sq.) / Basic step angle1.8°		42mm sq. (1.65inch sq.) / Basic step angle1.8°	
	Motor length	32mm (1.26inch)	51.5mm (2.03inch)	33mm (1.30inch)	39mm (1.54inch)
Single shaft	Set model number	DB14S281S	DB14S285S	DB14H521S	DB14H522S
	Configuration item: motor number	SH2281-5771	SH2285-5771	103H5205-5240	103H5208-5240
Double shaft	Set model number	DB14S281D	DB14S285D	DB14H521D	DB14H522D
	Configuration item: motor number	SH2281-5731	SH2285-5731	103H5205-5210	103H5208-5210
Holding torque	N · m (oz · in)	0.07 (9.91)	0.145 (20.53)	0.265 (37.53)	0.39 (55.23)
Rotor inertia	$\times 10^{-4} \text{kg} \cdot \text{m}^2$ (oz · in ²)	0.01 (0.05)	0.022 (0.12)	0.036 (0.20)	0.056 (0.31)
Rated current	A/phase	1	1	1	1
Motor mass ^(Note 1)	kg (lbs)	0.11 (0.24)	0.2 (0.44)	0.23 (0.51)	0.29 (0.64)
Allowable thrust load	N (lbs)	3 (0.67)	3 (0.67)	10 (2.25)	10 (2.25)
Allowable radial load ^(Note 2)	N (lbs)	42 (9.44)	49 (9.44)	30 (6)	30 (6)

(Note 1) Driver mass ▶ P.19

(Note2) When load is applied at 1/3 length from output shaft edge.

Characteristic drawing

With rubber coupling

Pull-out torque — Full step — Half step — fs : Maximum self-start frequency when not loaded
 Source current (no load) — Full step — Half step — Source current (load applied) — Full step — Half step

DB14S281S
DB14S281D

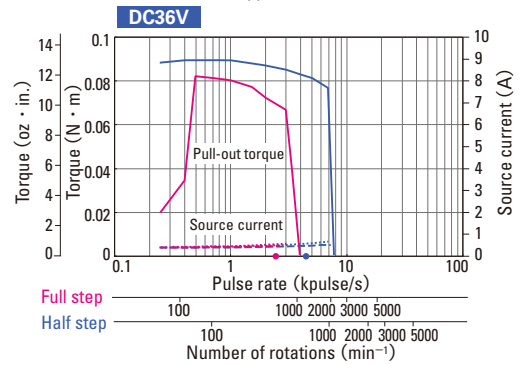
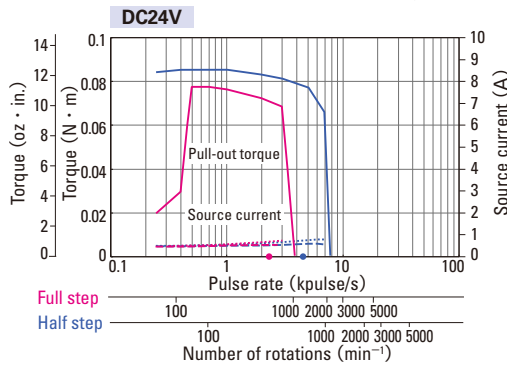

DB14S285S
DB14S285D

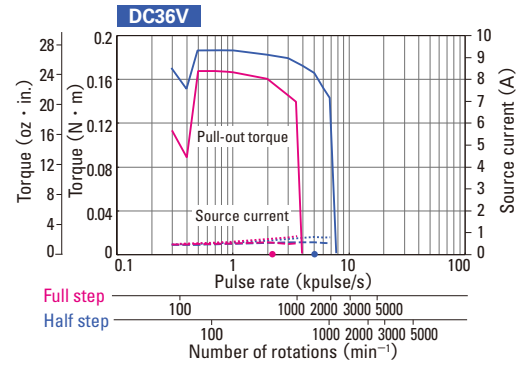
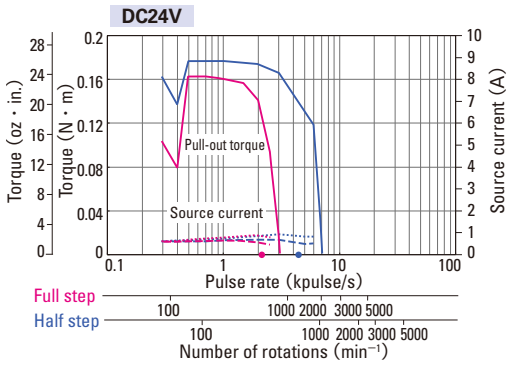

DB14H521S
DB14H521D

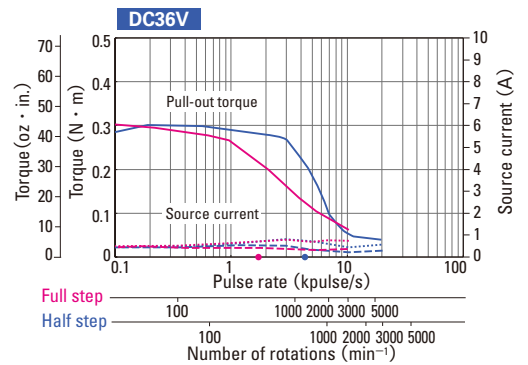
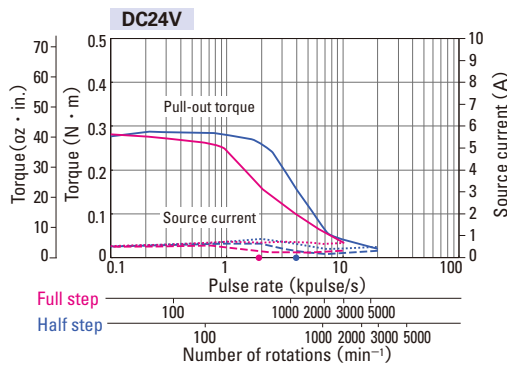

DB14H522S
DB14H522D

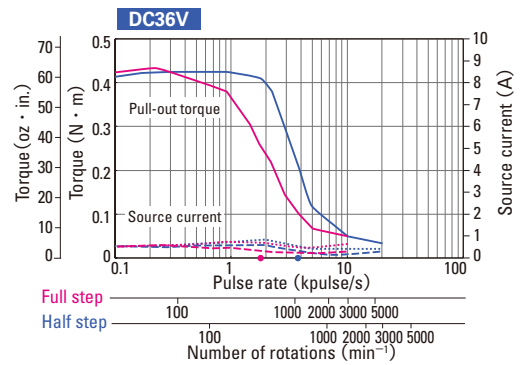
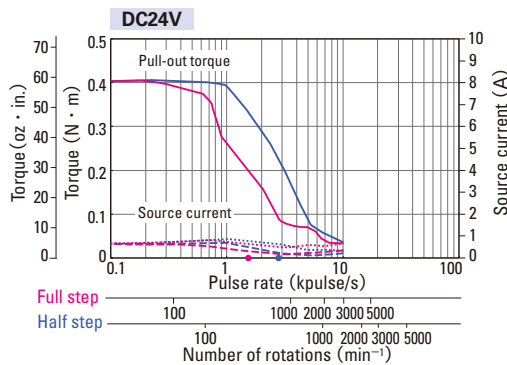

Size	Motor size	42mm sq. (1.65inch sq.) / Basic step angle 1.8°			
	Motor length	48mm (1.89inch)	33mm (1.30inch)	39mm (1.54inch)	48mm (1.89inch)
Single shaft	Set model number	DB14H524S	DB16S141S	DB16S142S	DB16S144S
	Configuration item: motor number	103H5210-5240	SH1421-5241	SH1422-5241	SH1424-5241
Double shaft	Set model number	DB14H524D	DB16S141D	DB16S142D	DB16S144D
	Configuration item: motor number	103H5210-5210	SH1421-5211	SH1422-5211	SH1424-5211
Holding torque	N · m (oz · in)	0.51 (72.22)	0.23 (32.57)	0.34 (48.15)	0.48 (67.97)
Rotor inertia	$\times 10^{-4}$ kg · m ² (oz · in ²)	0.074 (0.40)	0.044 (0.24)	0.066 (0.361)	0.089 (0.487)
Rated current	A/phase	1	2	2	2
Motor mass ^(Note 1)	kg (lbs)	0.37 (0.82)	0.24 (0.53)	0.29 (0.64)	0.38 (0.84)
Allowable thrust load	N (lbs)	10 (2.25)	10 (2.25)	10 (2.25)	10 (2.25)
Allowable radial load ^(Note 2)	N (lbs)	30 (6)	30 (6)	30 (6)	30 (6)

(Note 1) Driver mass ▶ P.19
 (Note2) When load is applied at 1/3 length from output shaft edge.

Characteristic drawing

With rubber coupling

Pull-out torque Full step Half step fs : Maximum self-start frequency when not loaded Full step Half step
 Source current (no load) Full step Half step Source current (load applied) Full step Half step

DB14H524S
DB14H524D

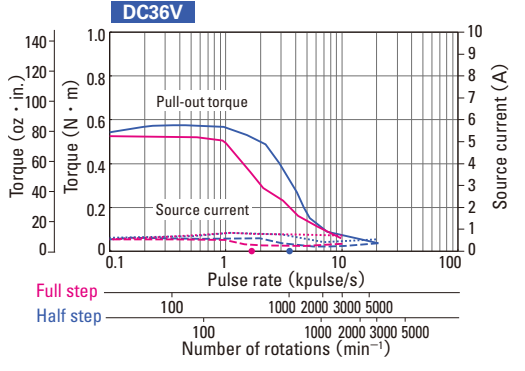
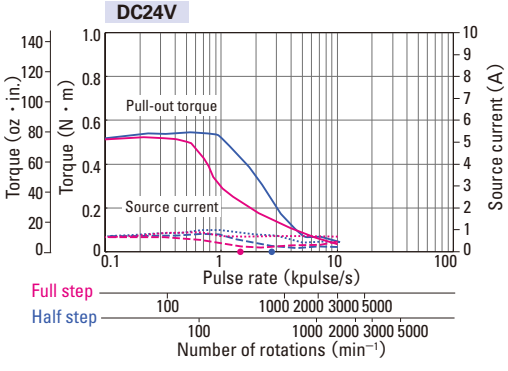

DB16S141S
DB16S141D

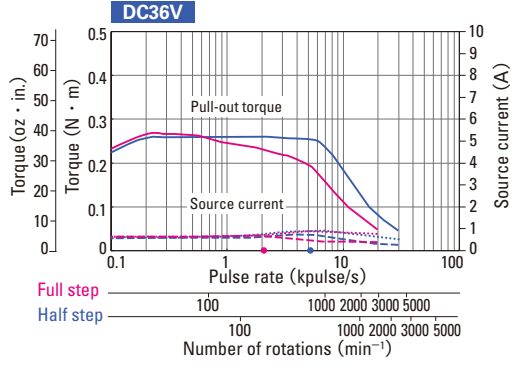
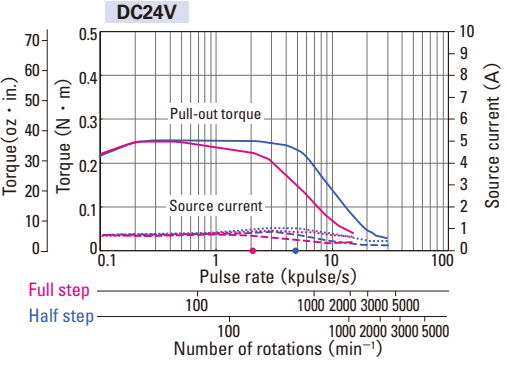

DB16S142S
DB16S142D

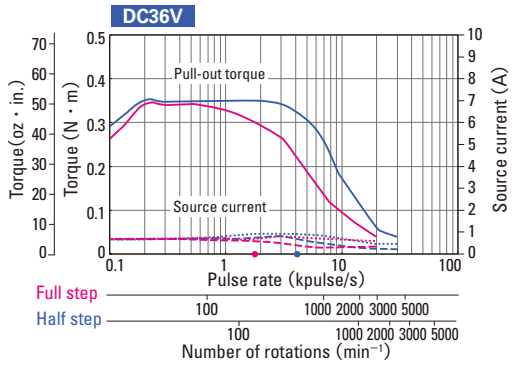
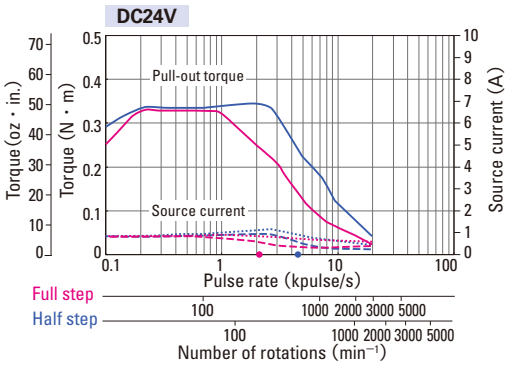

DB16S144S
DB16S144D

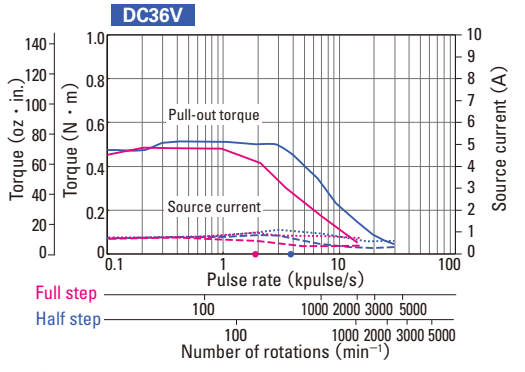
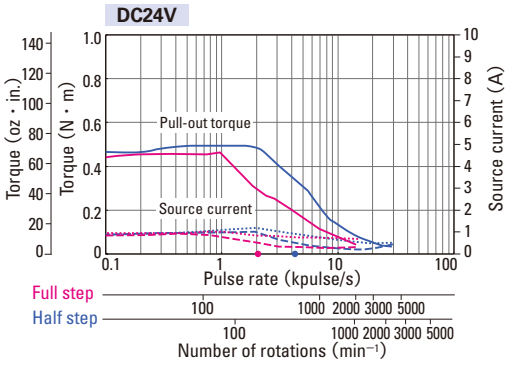

System configuration diagram ▶ P.8 Set Model Configuration ▶ P.10 Motor dimensions ▶ P.64 to 67 Driver dimensions ▶ P.70
 The data are measured under the drive condition of our company. Driving torque may vary according to actual machine precision.

Bipolar DC input driver (Model No.: BS1D200P10) + Motor

Size	Motor size	50mm sq. (1.97inch sq.) / Basic step angle 1.8°		56mm sq. (2.20inch sq.) / Basic step angle 1.8°	
	Motor length	39.8mm (1.57inch)	51.3mm (2.02inch)	41.8mm (1.65inch)	53.8mm (2.12inch)
Single shaft	Set model number	DB16H671S	DB16H673S	DB16H711S	DB16H713S
	Configuration item: motor number	103H6701-5040	103H6703-5040	103H7121-5740	103H7123-5740
Double shaft	Set model number	DB16H671D	DB16H673D	DB16H711D	DB16H713D
	Configuration item: motor number	103H6701-5010	103H6703-5010	103H7121-5710	103H7123-5710
Holding torque	N · m (oz · in)	0.28 (39.6)	0.49 (69.4)	0.55 (77.9)	1.0 (141.6)
Rotor inertia	$\times 10^{-4}$ kg · m ² (oz · in ²)	0.057 (0.31)	0.118 (0.65)	0.1 (0.55)	0.21 (1.15)
Rated current	A/phase	2	2	2	2
Motor mass ^(Note 1)	kg (lbs)	0.35 (0.77)	0.5 (1.10)	0.47 (1.04)	0.65 (1.43)
Allowable thrust load	N (lbs)	15 (3.37)	15 (3.37)	15 (3.37)	15 (3.37)
Allowable radial load ^(Note 2)	N (lbs)	99 (22)	99 (22)	71 (15)	71 (15)

(Note 1) Driver mass ▶ P.19

(Note2) When load is applied at 1/3 length from output shaft edge.

Characteristic drawing

With rubber coupling

Pull-out torque — Full step — Half step — fs : Maximum self-start frequency when not loaded
 Source current (no load) — Full step — Half step — Source current (load applied) — Full step — Half step

DB16H671S
DB16H671D

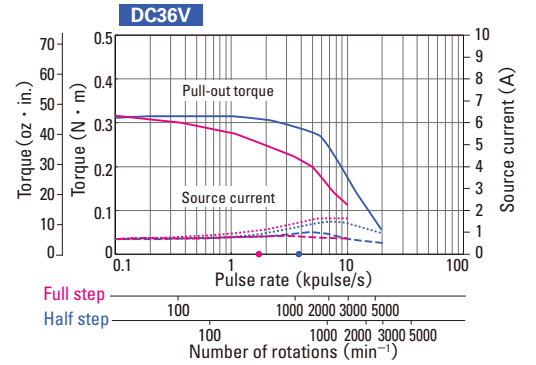
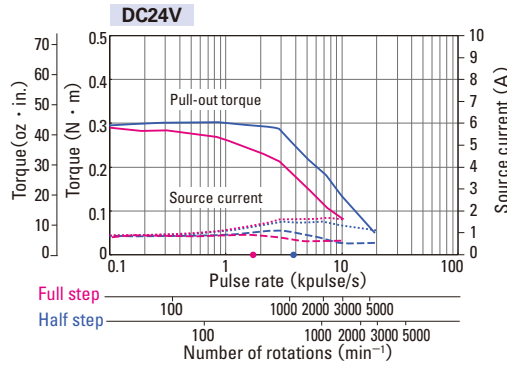

DB16H673S
DB16H673D

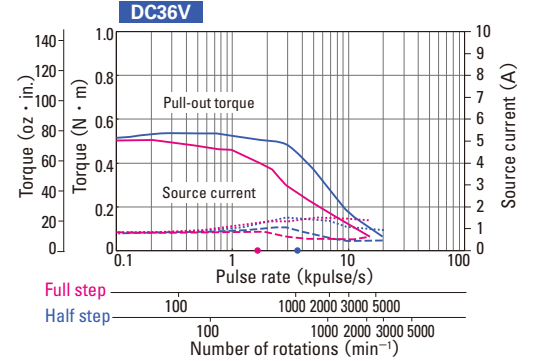
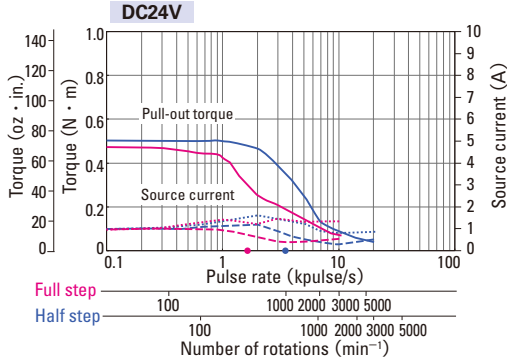

DB16H711S
DB16H711D

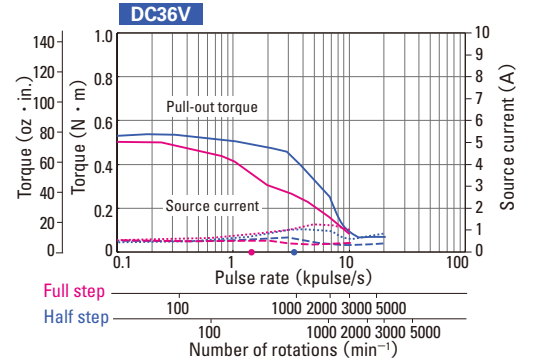
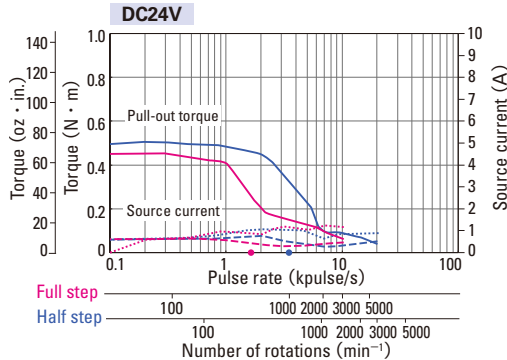

DB16H713S
DB16H713D

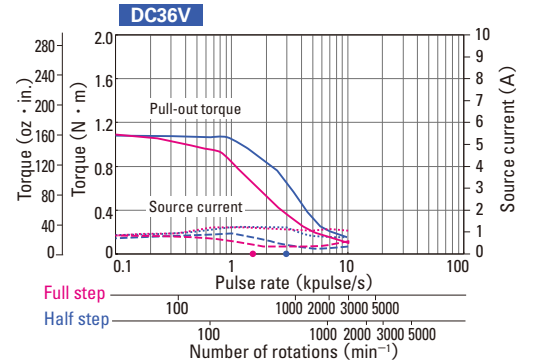
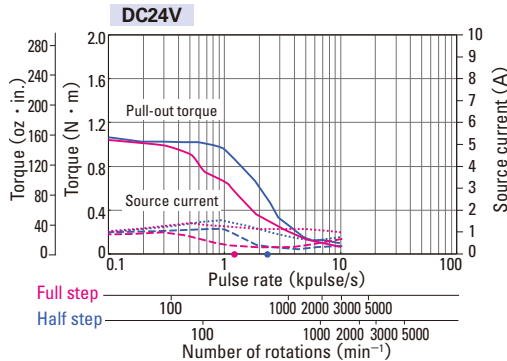

System configuration diagram ▶ P.8 Set Model Configuration ▶ P.10 Motor dimensions ▶ P.64 to 67 Driver dimensions ▶ P.70
 The data are measured under the drive condition of our company. Driving torque may vary according to actual machine precision.

Size	Motor size	60mm sq. (2.36inch sq.) / Basic step angle 1.8°			
	Motor length	75.8mm (2.98inch)	44.8mm (1.76inch)	53.8mm (2.12inch)	85.8mm (3.38inch)
Single shaft	Set model number	DB16H716S	DB16H781S	DB16H782S	DB16H783S
	Configuration item: motor number	103H7126-5740	103H7821-5740	103H7822-5740	103H7823-5740
Double shaft	Set model number	DB16H716D	DB16H781D	DB16H782D	DB16H783D
	Configuration item: motor number	103H7126-5710	103H7821-5710	103H7822-5710	103H7823-5710
Holding torque	N · m (oz · in)	1.6 (226.6)	0.88 (124.6)	1.37 (194.0)	2.7 (382.3)
Rotor inertia	$\times 10^{-4} \text{kg} \cdot \text{m}^2$ (oz · in ²)	0.36 (1.97)	0.275 (1.50)	0.4 (2.19)	0.84 (4.59)
Rated current	A/phase	2	2	2	2
Motor mass ^(Note 1)	kg (lbs)	0.98 (2.16)	0.6 (1.32)	0.77 (1.70)	1.34 (2.95)
Allowable thrust load	N (lbs)	15 (3.37)	15 (3.37)	15 (3.37)	15 (3.37)
Allowable radial load ^(Note 2)	N (lbs)	71 (15)	95 (21)	95 (21)	95 (21)

(Note 1) Driver mass ▶ P.19
 (Note2) When load is applied at 1/3 length from output shaft edge.

Characteristic drawing

With rubber coupling

Pull-out torque Source current (no load) Full step Half step fs : Maximum self-start frequency when not loaded Full step Half step
 Source current (load applied) Full step Half step

DB16H716S
DB16H716D

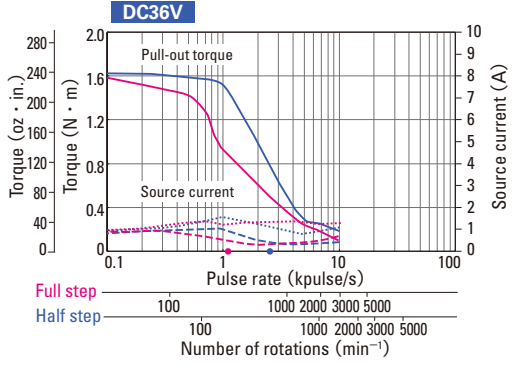
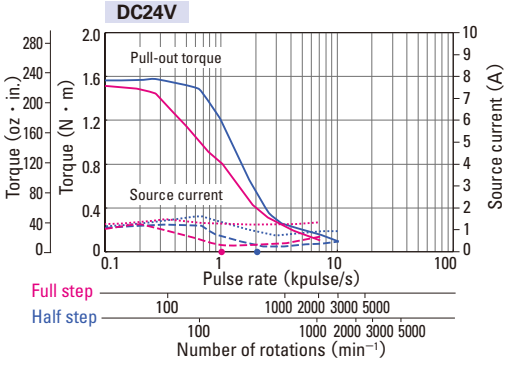

DB16H781S
DB16H781D

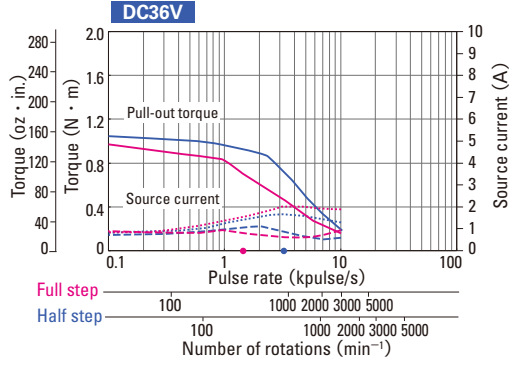
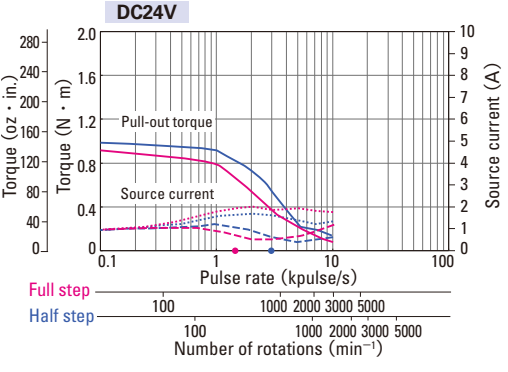

DB16H782S
DB16H782D

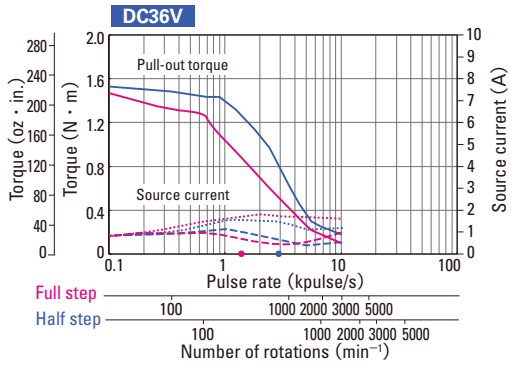
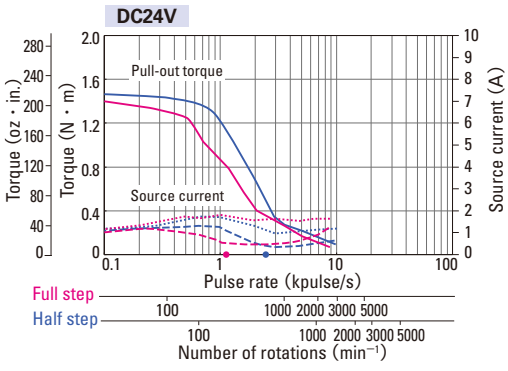

DB16H783S
DB16H783D

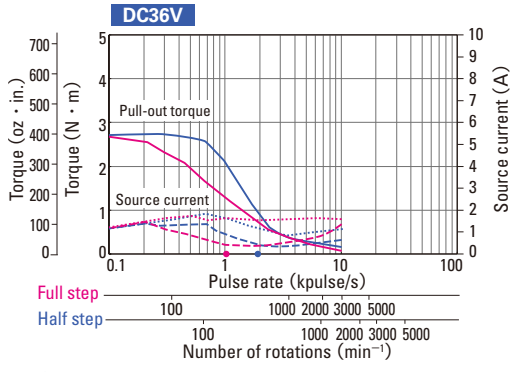
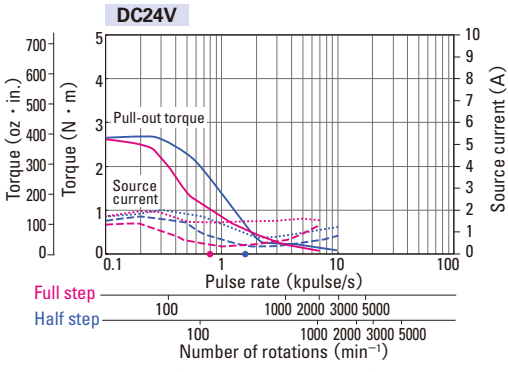

System configuration diagram ▶ P.8 Set Model Configuration ▶ P.10 Motor dimensions ▶ P.64 to 67 Driver dimensions ▶ P.70
 The data are measured under the drive condition of our company. Driving torque may vary according to actual machine precision.

Bipolar DC input driver (Model No.: BS1D200P10) + Motor

Size	Motor size	60mm sq. (2.36inch sq.) / Basic step angle 0.9°	
	Motor length	42mm (16.54inch)	54mm (21.26inch)
Single shaft	Set model number	DB16S161S	DB16S162S
	Configuration item: motor number	SH1601-5240	SH1602-5240
Double shaft	Set model number	DB16S161D	DB16S162D
	Configuration item: motor number	SH1601-5210	SH1602-5210
Holding torque	N · m (oz · in)	0.69 (97.71)	1.28 (181.26)
Rotor inertia	$\times 10^{-4}$ kg · m ² (oz · in ²)	0.24 (1.312)	0.4 (2.187)
Rated current	A/phase	2	2
Motor mass ^(Note 1)	kg (lbs)	0.55 (1.21)	0.8 (1.76)
Allowable thrust load	N (lbs)	15 (3.37)	15 (3.37)
Allowable radial load ^(Note 2)	N (lbs)	79 (18)	79 (18)

(Note 1) Driver mass ▶ P.19

(Note 2) When load is applied at 1/3 length from output shaft edge.

Characteristic drawing

With rubber coupling

— Pull-out torque Full step — Half step ● fs : Maximum self-start frequency when not loaded Full step ● Half step
- - - Source current (no load) Full step - - - Half step - - - Source current (load applied) Full step - - - Half step

DB16S161S
DB16S161D

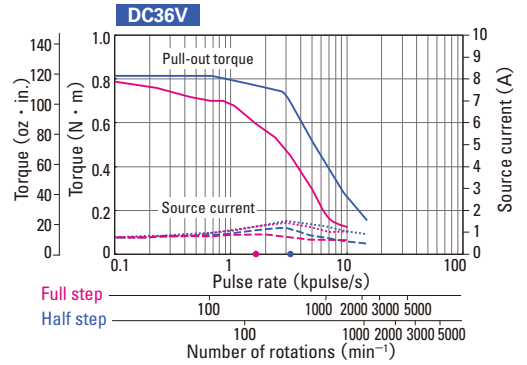
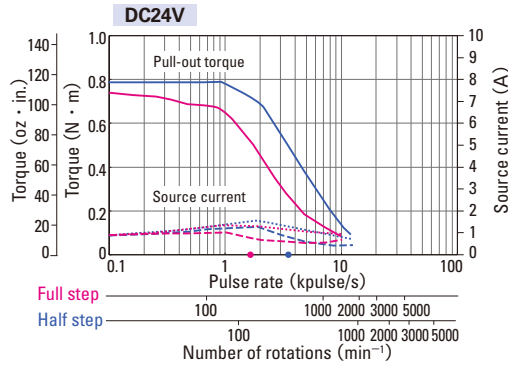

DB16S162S
DB16S162D

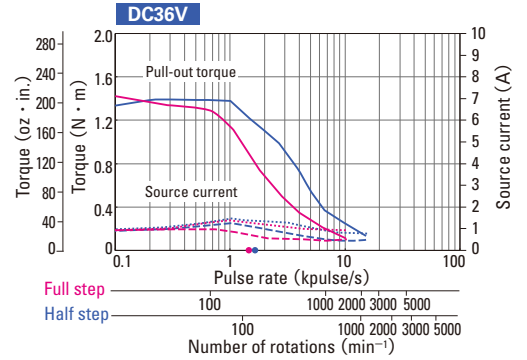
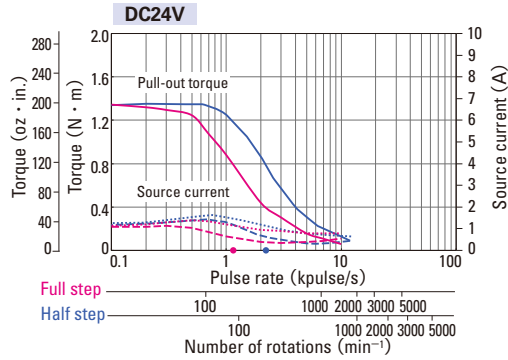

General Specifications

		Unipolar	Bipolar	
Basic specifications	Model number	US1D200P10	BS1D200P10	
	Input source	DC24 V/36 V ± 10 %		
	Source current	3 A		
	Environment	Protection class	Class III	
		Operation environment	Installation category (over-voltage category) : I , pollution degree : 2	
		Ambient operation temperature	0 to + 50°C	
		Conservation temperature	- 20 to + 70°C	
		Operating ambient humidity	35 to 85% RH (no condensation)	
		Conservation humidity	10 to 90% RH (no condensation)	
		Operation altitude	1000 m (3281 feet) or less above sea level	
		Vibration resistance	Tested under the following conditions; 5 m/s ² frequency range 10 to 55Hz, direction along X, Y and Z axes, for 2 hours each	
		Impact resistance	Not influenced at NDS-C-0110 standard section 3.2.2 division "C".	
		Withstand voltage	Not influenced when 0.5 kV AC is applied between power input terminal and cabinet for one minute.	
	Insulation resistance	10 M Ω MIN. when measured with 500V DC megohmmeter between input terminal and cabinet.		
Mass (Weight)	0.09 kg (0.20 lbs)			
Functions	Selection functions	Step angle, Pulse input mode, Low vibration mode, Step current, Operating current, Original excitation phase		
	Protection functions	Open phase protection, Main circuit power source voltage decrease		
	LED indication	Power monitor, alarm		
I/O signals	Command pulse input signal	Photo-coupler input system, input resistance : 220 Ω input-signal "H" level : 4.0 to 5.5 V, input-signal "L" level : 0 to 0.5 V Maximum input frequency : 150 kpulse/s		
	Power down input signal	Photo-coupler input system, input resistance : 220 Ω input-signal "H" level : 4.0 to 5.5V, input-signal "L" level : 0 to 0.5 V		
	Phase origin monitor output signal	From the photo coupler by the open collector output Output specification : V _{ceo} = 40 V MAX., I _c = 10 mA MAX.		
	Rotation monitor output signal	From the photo coupler by the open collector output Output specification : V _{ceo} = 40 V MAX., I _c = 10 mA MAX.		

Safety standards

	Directives	Category	Standard part	Name
CE (TÜV)	Low-voltage directives	—	EN61010-1	—
	EMC directives	Emission	EN55011-A	Terminal disturbance voltage
			EN55011-A	Electromagnetic radiation disturbance
		Immunity	EN61000-4-2	ESD (Electrostatic discharge)
			EN61000-4-3	RS (Radio-frequency amplitude modulated electromagnetic field)
			EN61000-4-4	Fast transients
			EN61000-4-6	Surges
UL	Acquired standards		Standard part	File No.
	UL		UL508C	E179775
	UL for Canada			

- EMC characteristics may vary depending on the configuration of the users' control panel, which contains the driver or stepping motor, or the arrangement and wiring of other electrical devices.
- Parts for EMC noise suppression like noise filters and toroidal type ferrite cores may be required depending on circumstances.
- Validation test of driver has been performed for low-voltage EMC directives at TÜV (TÜV product service) for self-declaration of CE marking.

Driver Controls and Connectors

Unipolar

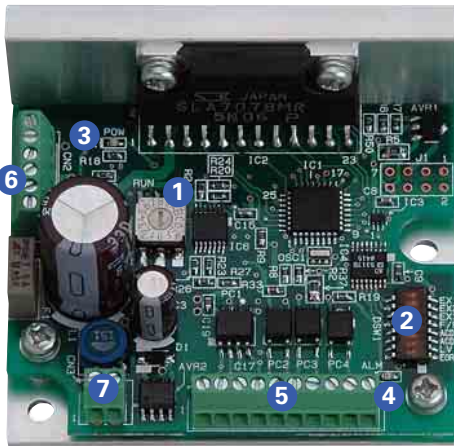

Bipolar

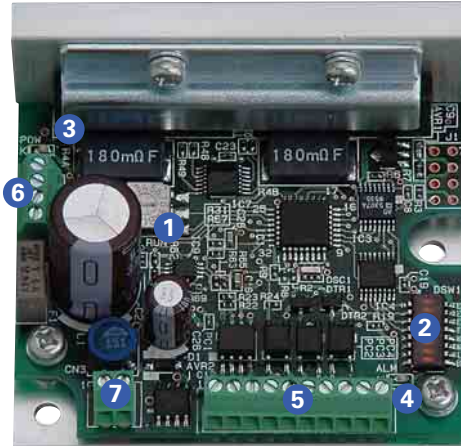

1 Driving current selection switch (RUN)

You can select the value of the motor current when driving.

Dial	0	1	2	3	4	5	6	7
Stepping motor current (A)	2.0	1.9	1.8	1.7	1.6	1.5	1.4	1.3
Dial	8	9	A	B	C	D	E	F
Stepping motor current (A)	1.2	1.1	1.0	0.9	0.8	0.7	0.6	0.5

- The factory setting is F (0.5A).
Select the current after checking the rated current of the combination motor.

2 Function selection DIP switchpack

Select the function depending on your specification.

Ex-factory settings

	OFF	ON	
EX1	<input type="checkbox"/>	<input type="checkbox"/>	Partition number: 8
EX2	<input type="checkbox"/>	<input type="checkbox"/>	
EX3	<input type="checkbox"/>	<input type="checkbox"/>	
F/R	<input type="checkbox"/>	<input type="checkbox"/>	Input method 2 (CW/CCW pulse input)
ACD1	<input type="checkbox"/>	<input type="checkbox"/>	Stopping current: 40% of driving current
ACD2	<input type="checkbox"/>	<input type="checkbox"/>	
LV	<input type="checkbox"/>	<input type="checkbox"/>	Micro step operation
EORG	<input type="checkbox"/>	<input type="checkbox"/>	Phase origin

1, Step angle select (EX1, EX2, EX3)

Select the partition number of the basic step angle.

EX1	EX2	EX3	Partition number
ON	ON	ON	1-division
OFF	ON	OFF	2-division
ON	OFF	OFF	4-division
OFF	OFF	OFF	8-division
OFF	OFF	ON	16-division

2, Input method select (F/R)

Selects input pulse type

F/R	Input pulse type
ON	1 input (CK, U/D)
OFF	2 input (CW, CCW)

3, Current selection when stopping (ACD1, ACD2)

Select the current value of the motor when stopping.

ACD2	ACD1	Current value of the motor
ON	ON	100% of driving current
ON	OFF	60% of driving current
OFF	ON	50% of driving current
OFF	OFF	40% of driving current

- Initial configuration of factory shipment is set to 40% of rated value.
Driver and motor should be operated at around 50% of rated value to reduce heat.

4, Low-vibration mode select (LV)

Provides low-vibration, smooth operation even if resolution is rough (1-division, 2-division, etc)

LV	Operation
ON	Auto-micro function
OFF	Micro-step

5, Excitation select (EORG)

The excitation phase when the power supply is turned on is selected.

EORG	Original excitation phase
ON	Excitation phase at power shut off
OFF	Phase origin

- By turning on the EORG, excitation phase when power OFF will be saved. Therefore, there will be no shaft displacement when turning the power ON.

3 LED for power supply monitor (POW)

Lit up when the main circuit power supply is connected.

4 LED for alarm display (ALM)

Lights in the following conditions

- Motor cable is broken.
- Switching element in driver is faulty.
- The main circuit voltage is out of specifications range (Less than 19V DC).

When "ALM" is displayed, the winding current of the stepping motor is cut off and it is in a "non-excitation" state. At the same time, an output signal (photocoupler ON) is transmitted from the alarm output terminal (AL) to an external source. When the alarm circuit is operating, this state is maintained until it is reset by switching on the power supply again. When an alarm condition has occurred, please take corrective actions to rectify the cause of the alarm before switching on the power supply again.

5 I/O signal terminal block (CN1)

Connect the I/O signal.

6 Motor terminal block (CN2)

Connect the motor's power line.

7 Power supply terminal block (CN3)

Connect the main circuit power supply.

Connections and Signals

External wiring diagram

Unipolar

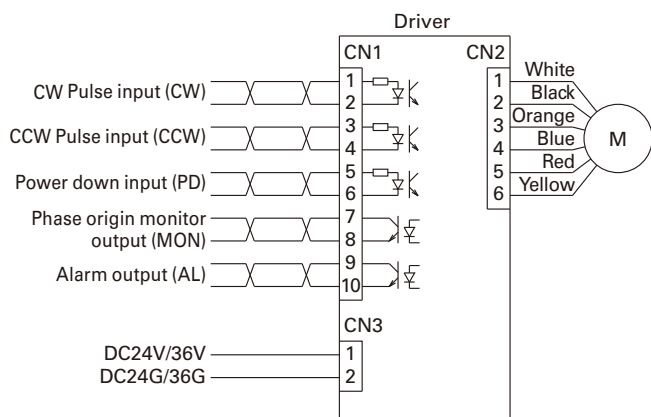

Bipolar

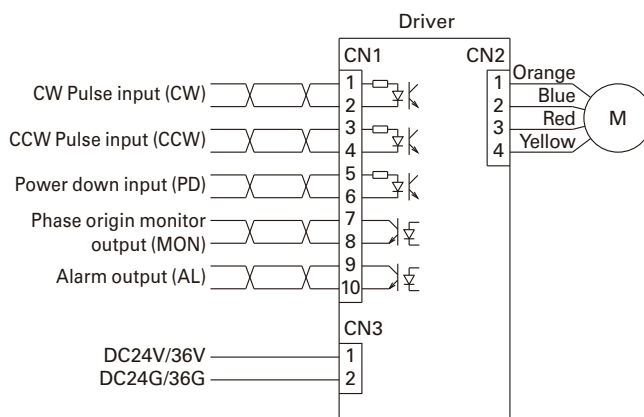

Applicable Wire Sizes

Part	Wire Sizes	Allowable wire length
For power supply	AWG22 (0.3mm ²)	2 m MAX.
For input/output signal	AWG24 (0.2mm ²) to AWG22 (0.3mm ²)	2 m MAX.
For motor	AWG22 (0.3mm ²)	Under 3 m

Specification Summary of Input/Output Signals

Signal	CN1 Pin Number	Function Summary
CW pulse input (CW) (Standard)	1 2	When "2 input mode", Input drive pulse rotating CW direction.
Pulse train input (CK)	1 2	When "1 input mode", Input drive pulse train for motor rotation.
CCW pulse input (CCW) (Standard)	3 4	When "2 input mode", Input drive pulse rotating CCW direction.
Rotational direction input (U/D)	3 4	When "1 input mode", Input motor rotational direction signal. Internal photo coupler ON ... CW direction Internal photo coupler OFF ... CCW direction
Power down input (PD)	5 6	Inputting PD signal will cut off (power off) the current flowing to the Motor (With dip switch select, change to the Power low function is possible). PD input signal on (internal photo coupler on) ... PD function is valid. PD input signal off (internal photo coupler off) ... PD function is invalid.
Phase origin monitor output (MON)	7 8	When the excitation phase is at the origin (in power on) it turns on. When FULL step, ON once for 4 pulses, when HALF step, ON once for 8 pulses.
Alarm output (AL)	9 10	When alarm circuits actuated inside the Driver, outputs signals to outside. Then the Stepping motor becomes unexcited status.

※ As for the Motor rotational direction, CW direction is regard as the clockwise revolution, and CCW direction is regard as the counterclockwise revolution by viewing the Motor from output shaft side.

Circuit configuration of pulse input CW (CK), CCW (U/D)

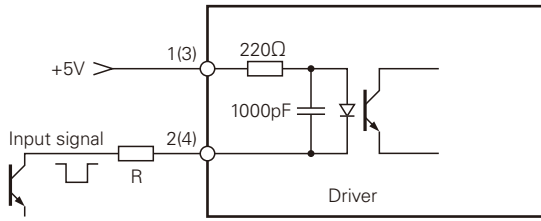

- Pulse duty 50% MAX.
- Maximum input frequency:150kpulse/s
- When the crest value of the input signal exceeds 5V, use the external limit resistance R to limit the input current to approximately 15mA.

Input signal specifications

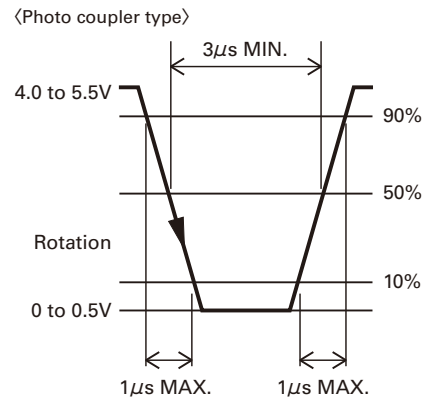

Timing of the command pulse

2 input mode (CW, CCW)

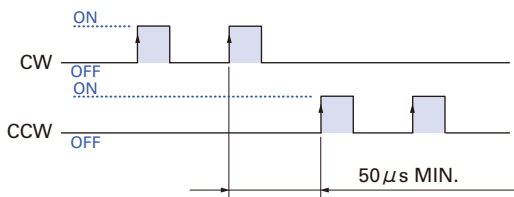

- Shaded area ■ indicates internal photo coupler "ON". Internal circuit (motor) starts operating at leading edge of the photo coupler "ON".
- To apply pulse to CW, set CCW side internal photo coupler to "OFF".
- To apply pulse to CCW, set CW side internal photo coupler to "OFF".

1 input type (CW, CCW)

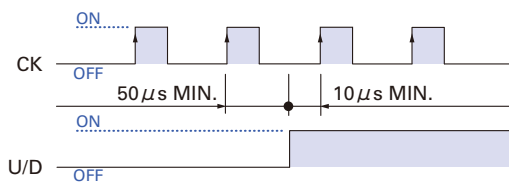

- Shaded area ■ indicates internal photo coupler "ON". Internal circuit (motor) starts operating at leading edge of CK side photo coupler "ON".
- Switching of U/D input signal must be done while CK side internal photo coupler is "OFF".

Input circuit configuration of power down input (PD)

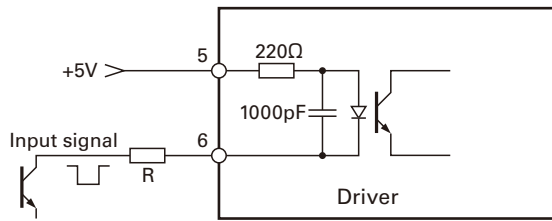

- When the crest value of the input signal exceeds 5V, use the external limit resistance R to limit the input current to approximately 15mA.

Output signal configuration of phase origin monitor output (MON) and alarm output (AL)

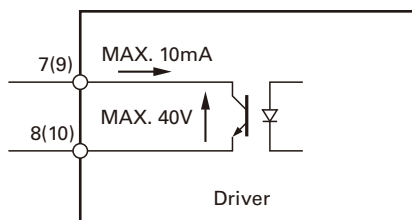

MON output

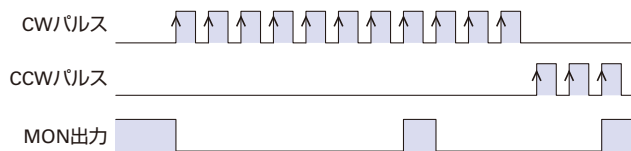

- Photo coupler at phase origin of motor excitation is set to "ON" (setting when number of divisions is 2)
- Output from MON is set to on at every 7.2 degrees of motor output shaft from phase origin.

Stepping Motor

Allowable load · Internal wiring · Rotation direction ▶ P.53

General Specifications ▶ P.54

Motor dimensions ▶ P.64 to 69



14mm sq. (0.55inch sq.)

1.8° /step

Bipolar winding · Lead wire type

Bipolar winding · Lead wire type

Model number		Holding torque at 2-phase energization	Rated current	Wiring resistance	Winding inductance	Rotor inertia	Mass (Weight)
Single shaft	Double shafts	[N · m (oz · in) MIN.]	A/phase	Ω /phase	mH/phase	[×10 ⁻⁴ kg · m ² (oz · in ²)]	[kg (lbs)]
SH2141-5541	SH2141-5511	0.0065 (0.92)	0.3	21	4.2	0.00058 (0.0032)	0.028 (0.062)

Characteristics diagram

SH2141-5541
SH2141-5511

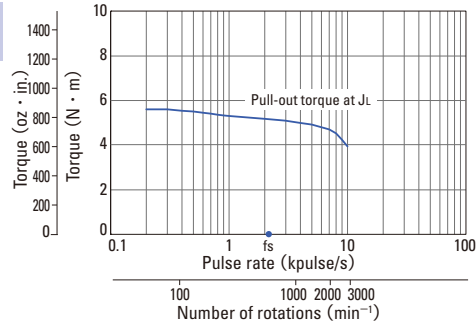

Constant current circuit
Source voltage : DC24V · Operating current : 0.3A/phase,
2-phase energization (full-step)
J_L=[0.01 × 10⁻⁴kg · m² (1.80 oz · in²) pulley balancer method]
fs: Maximum self-start frequency when not loaded



28mm sq. (1.10inch sq.)

1.8° /step

Unipolar winding · Lead wire type

Bipolar winding · Lead wire type ▶ P.26

Unipolar winding · Lead wire type

Model number		Holding torque at 2-phase energization	Rated current	Wiring resistance	Winding inductance	Rotor inertia	Mass (Weight)
Single shaft	Double shafts	[N · m (oz · in) MIN.]	A/phase	Ω /phase	mH/phase	[$\times 10^{-4}$ kg · m ² (oz · in ²)]	[kg (lbs)]
SH2281-5171	SH2281-5131	0.055 (7.79)	0.5	10.5	3.7	0.01 (0.05)	0.11 (0.24)
SH2281-5271	SH2281-5231	0.055 (7.79)	1	2.85	1	0.01 (0.05)	0.11 (0.24)
SH2285-5171	SH2285-5131	0.115 (16.28)	0.5	17	7	0.022 (0.12)	0.2 (0.44)
SH2285-5271	SH2285-5231	0.115 (16.28)	1	4.1	1.9	0.022 (0.12)	0.2 (0.44)

Characteristics diagram

SH2281-5171
SH2281-5131

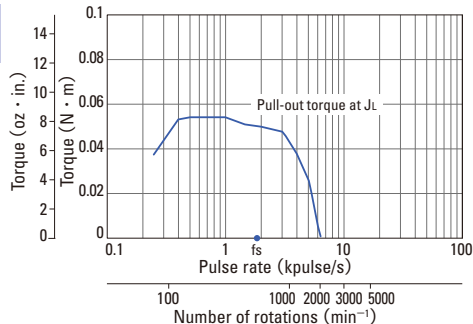

Constant current circuit
Source voltage : DC24V · Operating current : 0.5A/phase,
2-phase energization (full-step)
 $J_L = [0.01 \times 10^{-4} \text{kg} \cdot \text{m}^2 (1.80 \text{oz} \cdot \text{in}^2) \text{ pulley balancer method}]$
fs: Maximum self-start frequency when not loaded

SH2281-5271
SH2281-5231

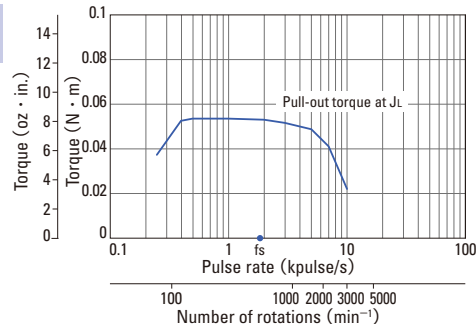

Constant current circuit
Source voltage : DC24V · Operating current : 1A/phase,
2-phase energization (full-step)
 $J_L = [0.01 \times 10^{-4} \text{kg} \cdot \text{m}^2 (1.80 \text{oz} \cdot \text{in}^2) \text{ pulley balancer method}]$
fs: Maximum self-start frequency when not loaded

SH2285-5171
SH2285-5131

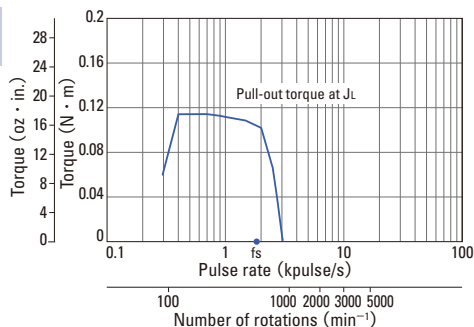

Constant current circuit
Source voltage : DC24V · Operating current : 0.5A/phase,
2-phase energization (full-step)
 $J_L = [0.01 \times 10^{-4} \text{kg} \cdot \text{m}^2 (1.80 \text{oz} \cdot \text{in}^2) \text{ pulley balancer method}]$
fs: Maximum self-start frequency when not loaded

SH2285-5271
SH2285-5231

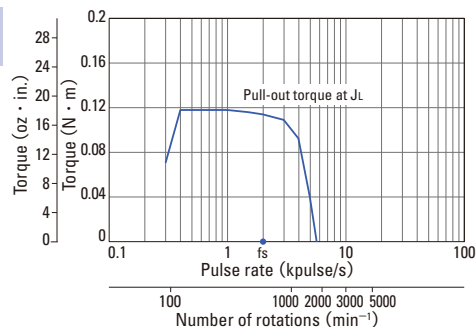

Constant current circuit
Source voltage : DC24V · Operating current : 1A/phase,
2-phase energization (full-step)
 $J_L = [0.01 \times 10^{-4} \text{kg} \cdot \text{m}^2 (1.80 \text{oz} \cdot \text{in}^2) \text{ pulley balancer method}]$
fs: Maximum self-start frequency when not loaded



28mm sq. (1.10inch sq.)

1.8° /step

Unipolar winding · Lead wire type ▶ P.25

Bipolar winding · Lead wire type

Bipolar winding · Lead wire type

Model number		Holding torque at 2-phase energization	Rated current	Wiring resistance	Winding inductance	Rotor inertia	Mass (Weight)
Single shaft	Double shafts	[N · m (oz · in) MIN.]	A/phase	Ω /phase	mH/phase	[×10 ⁻⁴ kg · m ² (oz · in ²)]	[kg (lbs)]
SH2281-5671	SH2281-5631	0.07 (9.91)	0.5	10.5	7.2	0.01 (0.05)	0.11 (0.24)
SH2281-5771	SH2281-5731	0.07 (9.91)	1	2.6	1.85	0.01 (0.05)	0.11 (0.24)
SH2285-5671	SH2285-5631	0.145 (20.53)	0.5	15	13.5	0.022 (0.12)	0.2 (0.44)
SH2285-5771	SH2285-5731	0.145 (20.53)	1	3.75	3.4	0.022 (0.12)	0.2 (0.44)

Characteristics diagram

SH2281-5671
SH2281-5631

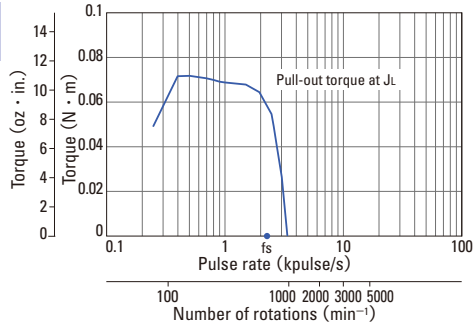

Constant current circuit
Source voltage : DC24V · Operating current : 0.5A/phase,
2-phase energization (full-step)
 $J_L=[0.01 \times 10^{-4} \text{kg} \cdot \text{m}^2 (1.80 \text{oz} \cdot \text{in}^2) \text{ pulley balancer method}]$
fs: Maximum self-start frequency when not loaded

SH2281-5771
SH2281-5731

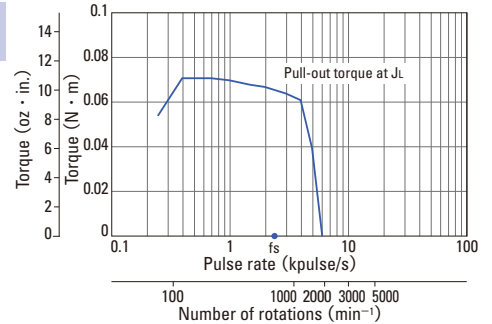

Constant current circuit
Source voltage : DC24V · Operating current : 1A/phase,
2-phase energization (full-step)
 $J_L=[0.01 \times 10^{-4} \text{kg} \cdot \text{m}^2 (1.80 \text{oz} \cdot \text{in}^2) \text{ pulley balancer method}]$
fs: Maximum self-start frequency when not loaded

SH2285-5671
SH2285-5631

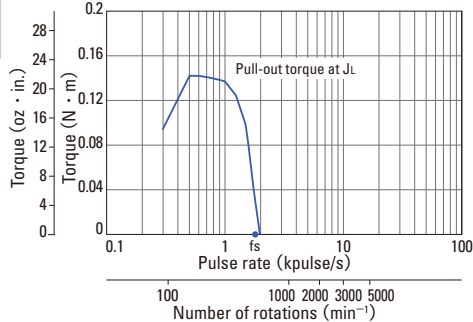

Constant current circuit
Source voltage : DC24V · Operating current : 0.5A/phase,
2-phase energization (full-step)
 $J_L=[0.01 \times 10^{-4} \text{kg} \cdot \text{m}^2 (1.80 \text{oz} \cdot \text{in}^2) \text{ pulley balancer method}]$
fs: Maximum self-start frequency when not loaded

SH2285-5771
SH2285-5731

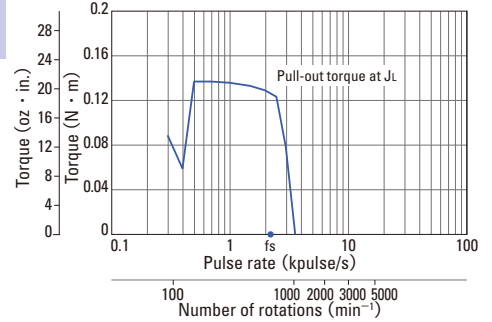

Constant current circuit
Source voltage : DC24V · Operating current : 1A/phase,
2-phase energization (full-step)
 $J_L=[0.01 \times 10^{-4} \text{kg} \cdot \text{m}^2 (1.80 \text{oz} \cdot \text{in}^2) \text{ pulley balancer method}]$
fs: Maximum self-start frequency when not loaded



35mm sq. (1.38inch sq.)

1.8° /step

Unipolar winding · Lead wire type

Unipolar winding · Lead wire type

Model number		Holding torque at 2-phase energization	Rated current	Wiring resistance	Winding inductance	Rotor inertia	Mass (Weight)
Single shaft	Double shafts	[N · m (oz · in) MIN.]	A/phase	Ω /phase	mH/phase	[×10 ⁻⁴ kg · m ² (oz · in ²)]	[kg (lbs)]
SH3533-12U40	SH3533-12U10	0.12 (16.99)	1.2	2.4	1.3	0.02 (1.09)	0.17 (0.37)
SH3537-12U40	SH3537-12U10	0.15 (21.24)	1.2	2.7	2	0.025 (1.37)	0.2 (0.44)
SH3552-12U40	SH3552-12U10	0.23 (32.57)	1.2	3.4	2.8	0.043 (2.35)	0.3 (0.66)

Characteristics diagram

SH3533-12U40
SH3533-12U10

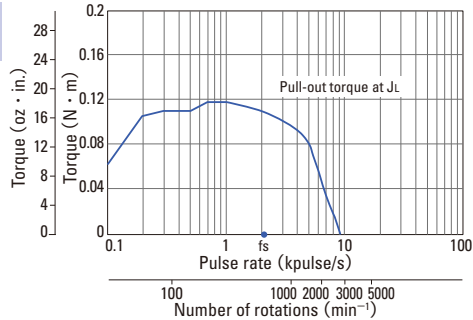

Constant current circuit
Source voltage : DC24V · Operating current : 1.2A/phase,
2-phase energization (full-step)
 $J_t = [0.33 \times 10^{-4} \text{kg} \cdot \text{m}^2 (1.80 \text{oz} \cdot \text{in}^2)$ use the rubber coupling]
fs: Maximum self-start frequency when not loaded

SH3537-12U40
SH3537-12U10

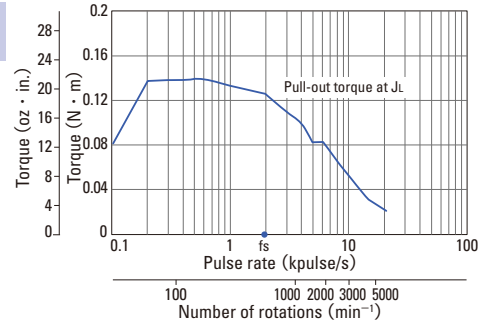

Constant current circuit
Source voltage : DC24V · Operating current : 1.2A/phase,
2-phase energization (full-step)
 $J_t = [0.33 \times 10^{-4} \text{kg} \cdot \text{m}^2 (1.80 \text{oz} \cdot \text{in}^2)$ use the rubber coupling]
fs: Maximum self-start frequency when not loaded

SH3552-12U40
SH3552-12U10

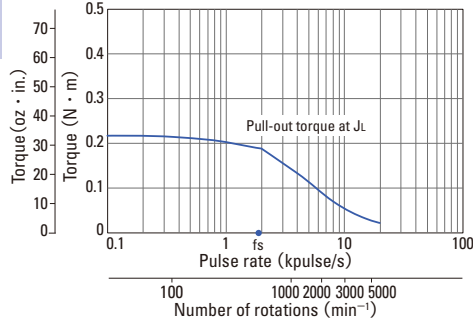

Constant current circuit
Source voltage : DC24V · Operating current : 1.2A/phase,
2-phase energization (full-step)
 $J_t = [0.94 \times 10^{-4} \text{kg} \cdot \text{m}^2 (5.14 \text{oz} \cdot \text{in}^2)$ use the rubber coupling]
fs: Maximum self-start frequency when not loaded



42mm sq. (1.65inch sq.)

1.8° /step **Slim form**

Bipolar winding · Lead wire type

Bipolar winding · Lead wire type

Model number		Holding torque at 2-phase energization	Rated current	Wiring resistance	Winding inductance	Rotor inertia	Mass (Weight)
Single shaft	Double shafts	[N · m (oz · in) MIN.]	A/phase	Ω /phase	mH/phase	[×10 ⁻⁴ kg · m ² (oz · in ²)]	[kg (lbs)]
SS2421-5041	SS2421-5011	0.083 (11.75)	1	3.5	1.2	0.015 (0.082)	0.07 (0.15)
SS2422-5041	SS2422-5011	0.186 (26.33)	1	5.4	2.9	0.028 (0.153)	0.14 (0.31)

Characteristics diagram

SS2421-5041
SS2421-5011

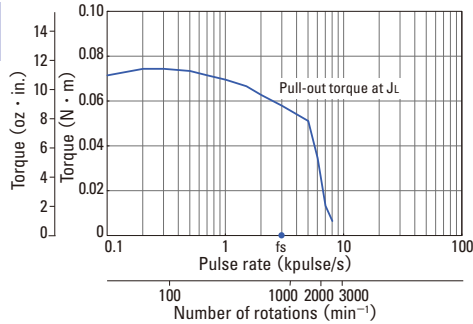

Constant current circuit
Source voltage : DC24V · Operating current : 1A/phase,
2-phase energization (full-step)
 $J_L = [0.33 \times 10^{-4} \text{kg} \cdot \text{m}^2 (1.80 \text{oz} \cdot \text{in}^2) \text{ use the rubber coupling}]$
fs: Maximum self-start frequency when not loaded

SS2422-5041
SS2422-5011

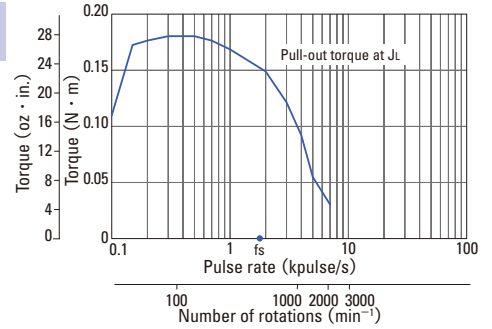

Constant current circuit
Source voltage : DC24V · Operating current : 1A/phase,
2-phase energization (full-step)
 $J_L = [0.33 \times 10^{-4} \text{kg} \cdot \text{m}^2 (1.80 \text{oz} \cdot \text{in}^2) \text{ use the rubber coupling}]$
fs: Maximum self-start frequency when not loaded



42mm sq. (1.65inch sq.)

0.9° /step

Unipolar winding · Lead wire type

Bipolar winding · Lead wire type ▶ P.30

Unipolar winding · Lead wire type

Model number		Holding torque at 2-phase energization	Rated current	Wiring resistance	Winding inductance	Rotor inertia	Mass (Weight)
Single shaft	Double shafts	[N · m (oz · in) MIN.]	A/phase	Ω /phase	mH/phase	[×10 ⁻⁴ kg · m ² (oz · in ²)]	[kg (lbs)]
SH1421-0441	SH1421-0411	0.20 (28.32)	1.2	2.7	3.2	0.044 (0.241)	0.24 (0.53)
SH1422-0441	SH1422-0411	0.29 (41.07)	1.2	3.1	5.3	0.066 (0.361)	0.29 (0.64)
SH1424-0441	SH1424-0411	0.39 (55.23)	1.2	3.5	5.3	0.089 (0.487)	0.38 (0.84)

Characteristics diagram

SH1421-0441
SH1421-0411

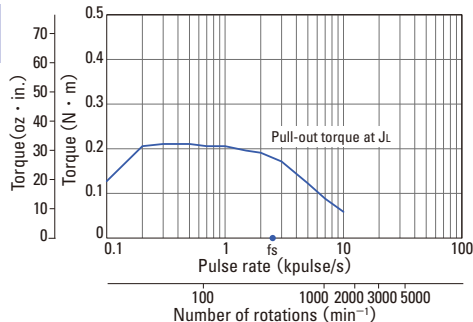

Constant current circuit
Source voltage : DC24V · Operating current : 1.2A/phase,
2-phase energization (full-step)
J_L=[0.94 × 10⁻⁴kg · m² (5.14 oz · in²) use the rubber coupling]
fs: Maximum self-start frequency when not loaded

SH1422-0441
SH1422-0411

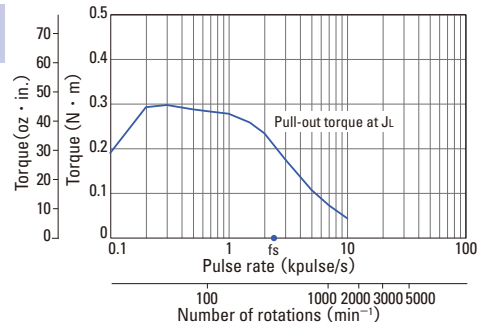

Constant current circuit
Source voltage : DC24V · Operating current : 1.2A/phase,
2-phase energization (full-step)
J_L=[0.94 × 10⁻⁴kg · m² (5.14 oz · in²) use the rubber coupling]
fs: Maximum self-start frequency when not loaded

SH1424-0441
SH1424-0411

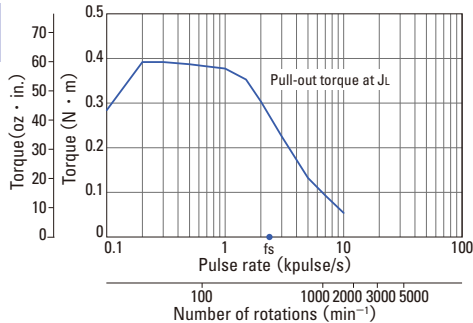

Constant current circuit
Source voltage : DC24V · Operating current : 1.2A/phase,
2-phase energization (full-step)
J_L=[0.94 × 10⁻⁴kg · m² (5.14 oz · in²) use the rubber coupling]
fs: Maximum self-start frequency when not loaded



42mm sq. (1.65inch sq.)

0.9° /step

Unipolar winding · Lead wire type ▶ P.29
Bipolar winding · Lead wire type

Bipolar winding · Lead wire type

Model number		Holding torque at 2-phase energization	Rated current	Wiring resistance	Winding inductance	Rotor inertia	Mass (Weight)
Single shaft	Double shafts	[N · m (oz · in) MIN.]	A/phase	Ω /phase	mH/phase	[×10 ⁻⁴ kg · m ² (oz · in ²)]	[kg (lbs)]
SH1421-5041	SH1421-5011	0.23 (32.5)	1	3.3	8.0	0.044 (0.24)	0.24 (0.53)
SH1421-5241	SH1421-5211	0.23 (32.5)	2	0.85	2.1	0.044 (0.24)	0.24 (0.53)
SH1422-5041	SH1422-5011	0.34 (48.1)	1	4.0	14.0	0.066 (0.36)	0.29 (0.64)
SH1422-5241	SH1422-5211	0.34 (48.1)	2	1.05	3.6	0.066 (0.36)	0.29 (0.64)
SH1424-5041	SH1424-5011	0.48 (67.9)	1	4.7	15.0	0.089 (0.49)	0.38 (0.84)
SH1424-5241	SH1424-5211	0.48 (67.9)	2	1.25	3.75	0.089 (0.49)	0.38 (0.84)

Characteristics diagram

SH1421-5041
SH1421-5011

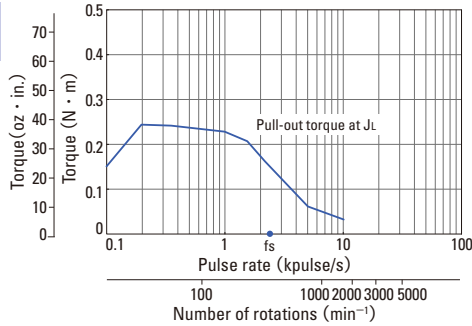

Constant current circuit
Source voltage : DC24V · Operating current : 1A/phase,
2-phase energization (full-step)
 $J_L=[0.94 \times 10^{-4} \text{kg} \cdot \text{m}^2 (5.14 \text{oz} \cdot \text{in}^2)$ use the rubber coupling]
fs: Maximum self-start frequency when not loaded

SH1421-5241
SH1421-5211

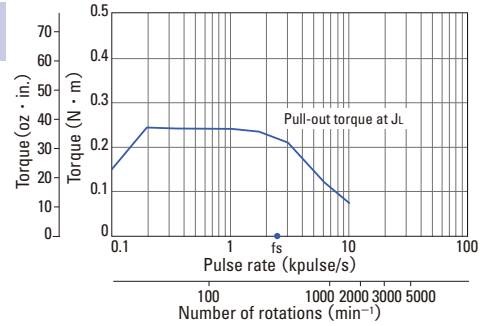

Constant current circuit
Source voltage : DC24V · Operating current : 2A/phase,
2-phase energization (full-step)
 $J_L=[0.94 \times 10^{-4} \text{kg} \cdot \text{m}^2 (5.14 \text{oz} \cdot \text{in}^2)$ use the rubber coupling]
fs: Maximum self-start frequency when not loaded

SH1422-5041
SH1422-5011

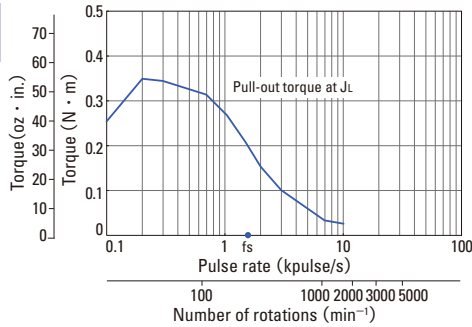

Constant current circuit
Source voltage : DC24V · Operating current : 1A/phase,
2-phase energization (full-step)
 $J_L=[0.94 \times 10^{-4} \text{kg} \cdot \text{m}^2 (5.14 \text{oz} \cdot \text{in}^2)$ use the rubber coupling]
fs: Maximum self-start frequency when not loaded

SH1422-5241
SH1422-5211

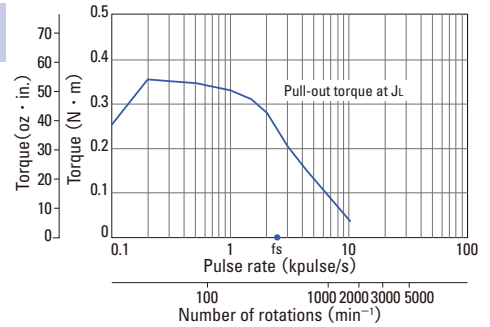

Constant current circuit
Source voltage : DC24V · Operating current : 2A/phase,
2-phase energization (full-step)
 $J_L=[0.94 \times 10^{-4} \text{kg} \cdot \text{m}^2 (5.14 \text{oz} \cdot \text{in}^2)$ use the rubber coupling]
fs: Maximum self-start frequency when not loaded

SH1424-5041
SH1424-5011

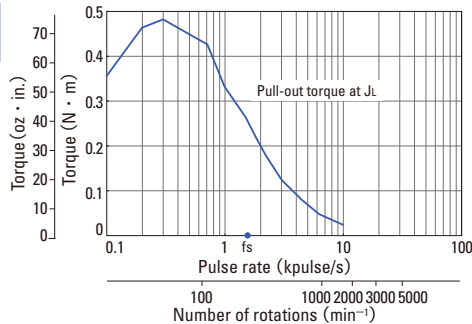

Constant current circuit
Source voltage : DC24V · Operating current : 1A/phase,
2-phase energization (full-step)
 $J_L=[0.94 \times 10^{-4} \text{kg} \cdot \text{m}^2 (5.14 \text{oz} \cdot \text{in}^2)$ use the rubber coupling]
fs: Maximum self-start frequency when not loaded

SH1424-5241
SH1424-5211

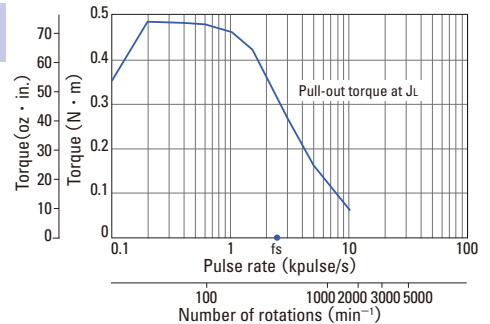

Constant current circuit
Source voltage : DC24V · Operating current : 2A/phase,
2-phase energization (full-step)
 $J_L=[0.94 \times 10^{-4} \text{kg} \cdot \text{m}^2 (5.14 \text{oz} \cdot \text{in}^2)$ use the rubber coupling]
fs: Maximum self-start frequency when not loaded



42mm sq. (1.65inch sq.)

1.8° /step

Unipolar winding · Connector type
Bipolar winding · Lead wire type ▶ P.32

Unipolar winding · Connector type

Model number		Holding torque at 2-phase energization	Rated current	Wiring resistance	Winding inductance	Rotor inertia	Mass (Weight)
Single shaft	Double shafts	[N · m (oz · in) MIN.]	A/phase	Ω /phase	mH/phase	[×10 ⁻⁴ kg · m ² (oz · in ²)]	[kg (lbs)]
103H5205-0440	103H5205-0410	0.2 (28.32)	1.2	2.4	2.3	0.036 (0.20)	0.23 (0.51)
103H5208-0440	103H5208-0410	0.3 (42.48)	1.2	2.9	3.4	0.056 (0.31)	0.29 (0.64)
103H5209-0440	103H5209-0410	0.32 (45.31)	1.2	3	3.9	0.062 (0.34)	0.31 (0.68)
103H5210-0440	103H5210-0410	0.37 (52.39)	1.2	3.3	3.4	0.074 (0.40)	0.37 (0.82)

Motor cable : Model No.4835710-1

Characteristics diagram

103H5205-0440
103H5205-0410

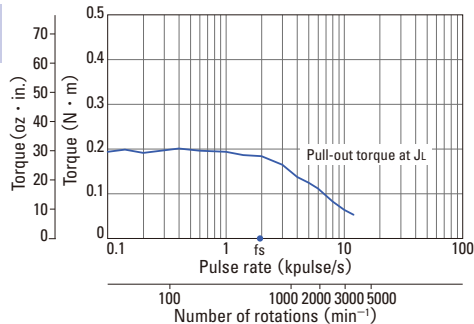

Constant current circuit
Source voltage : DC24V · Operating current : 1.2A/phase,
2-phase energization (full-step)
 $J_L = [0.94 \times 10^{-4} \text{kg} \cdot \text{m}^2 (5.14 \text{oz} \cdot \text{in}^2)$ use the rubber coupling]
fs: Maximum self-start frequency when not loaded

103H5208-0440
103H5208-0410

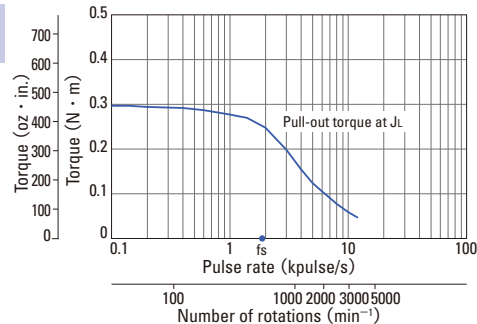

Constant current circuit
Source voltage : DC24V · Operating current : 1.2A/phase,
2-phase energization (full-step)
 $J_L = [0.94 \times 10^{-4} \text{kg} \cdot \text{m}^2 (5.14 \text{oz} \cdot \text{in}^2)$ use the rubber coupling]
fs: Maximum self-start frequency when not loaded

103H5209-0440
103H5209-0410

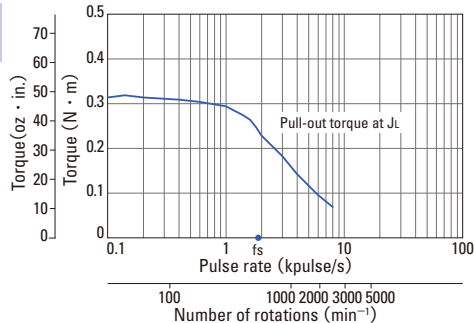

Constant current circuit
Source voltage : DC24V · Operating current : 1.2A/phase,
2-phase energization (full-step)
 $J_L = [0.94 \times 10^{-4} \text{kg} \cdot \text{m}^2 (5.14 \text{oz} \cdot \text{in}^2)$ use the rubber coupling]
fs: Maximum self-start frequency when not loaded

103H5210-0440
103H5210-0410

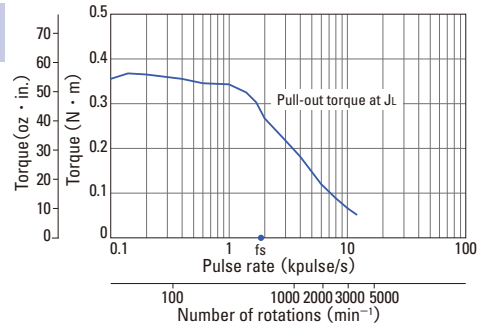

Constant current circuit
Source voltage : DC24V · Operating current : 1.2A/phase,
2-phase energization (full-step)
 $J_L = [0.94 \times 10^{-4} \text{kg} \cdot \text{m}^2 (5.14 \text{oz} \cdot \text{in}^2)$ use the rubber coupling]
fs: Maximum self-start frequency when not loaded



Photo: Connector type

42mm sq. (1.65inch sq.)

1.8° /step

Unipolar winding · Connector type ▶ P.31
Bipolar winding · Lead wire type

Bipolar winding · Lead wire type

Model number		Holding torque at 2-phase energization	Rated current	Wiring resistance	Winding inductance	Rotor inertia	Mass (Weight)
Single shaft	Double shafts	[N · m (oz · in) MIN.]	A/phase	Ω /phase	mH/phase	[×10 ⁻⁴ kg · m ² (oz · in ²)]	[kg (lbs)]
103H5205-5040	103H5205-5010	0.23 (32.57)	0.25	54	78	0.036 (0.20)	0.23 (0.51)
103H5205-5140	103H5205-5110	0.25 (35.40)	0.5	13.4	23.4	0.036 (0.20)	0.23 (0.51)
103H5205-5240	103H5205-5210	0.265 (37.53)	1	3.4	6.5	0.036 (0.20)	0.23 (0.51)
103H5208-5040	103H5208-5010	0.35 (49.56)	0.25	66	116	0.056 (0.31)	0.29 (0.64)
103H5208-5140	103H5208-5110	0.38 (53.81)	0.5	16.5	34	0.056 (0.31)	0.29 (0.64)
103H5208-5240	103H5208-5210	0.39 (55.23)	1	4.1	9.5	0.056 (0.31)	0.29 (0.64)
103H5209-5040	103H5209-5010	0.38 (53.81)	0.25	71.4	133	0.062 (0.34)	0.31 (0.68)
103H5209-5140	103H5209-5110	0.41 (58.06)	0.5	18.2	39	0.062 (0.34)	0.31 (0.68)
103H5209-5240	103H5209-5210	0.425 (60.18)	1	4.4	11	0.062 (0.34)	0.31 (0.68)
103H5210-5040	103H5210-5010	0.465 (65.85)	0.25	80	123.3	0.074 (0.40)	0.37 (0.82)
103H5210-5140	103H5210-5110	0.49 (69.39)	0.5	20	35	0.074 (0.40)	0.37 (0.82)
103H5210-5240	103H5210-5210	0.51 (72.22)	1	4.8	9.5	0.074 (0.40)	0.37 (0.82)

Characteristics diagram

103H5205-5040
103H5205-5010

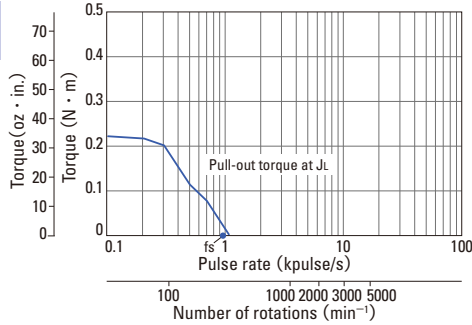

Constant current circuit
Source voltage : DC24V · Operating current : 0.25A/phase,
2-phase energization (full-step)
 $J_L = [0.94 \times 10^{-4} \text{kg} \cdot \text{m}^2 (5.14 \text{oz} \cdot \text{in}^2)$ use the rubber coupling]
fs: Maximum self-start frequency when not loaded

103H5205-5140
103H5205-5110

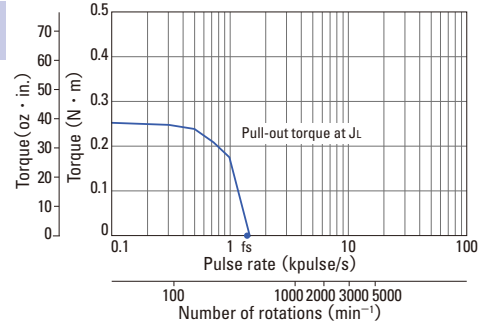

Constant current circuit
Source voltage : DC24V · Operating current : 0.5A/phase,
2-phase energization (full-step)
 $J_L = [0.94 \times 10^{-4} \text{kg} \cdot \text{m}^2 (5.14 \text{oz} \cdot \text{in}^2)$ use the rubber coupling]
fs: Maximum self-start frequency when not loaded

103H5205-5240
103H5205-5210

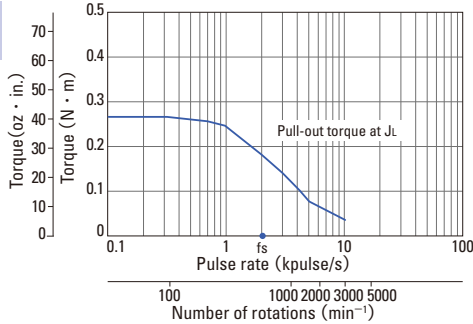

Constant current circuit
Source voltage : DC24V · Operating current : 1A/phase,
2-phase energization (full-step)
 $J_L = [0.94 \times 10^{-4} \text{kg} \cdot \text{m}^2 (5.14 \text{oz} \cdot \text{in}^2)$ use the rubber coupling]
fs: Maximum self-start frequency when not loaded

103H5208-5040
103H5208-5010

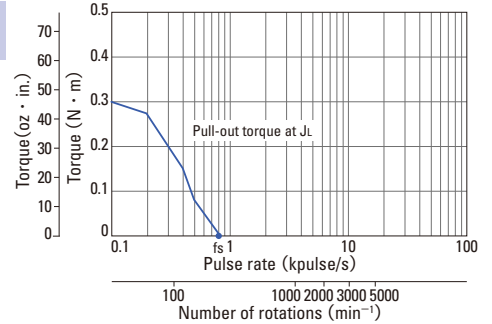

Constant current circuit
Source voltage : DC24V · Operating current : 0.25A/phase,
2-phase energization (full-step)
 $J_L = [0.94 \times 10^{-4} \text{kg} \cdot \text{m}^2 (5.14 \text{oz} \cdot \text{in}^2)$ use the rubber coupling]
fs: Maximum self-start frequency when not loaded

Characteristics diagram

103H5208-5140
103H5208-5110

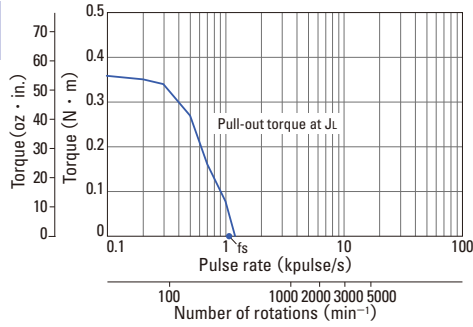

Constant current circuit
Source voltage : DC24V · Operating current : 0.5A/phase,
2-phase energization (full-step)
 $J_L=[0.94 \times 10^{-4} \text{kg} \cdot \text{m}^2$ (5.14 oz · in²) use the rubber coupling]
fs: Maximum self-start frequency when not loaded

103H5208-5240
103H5208-5210

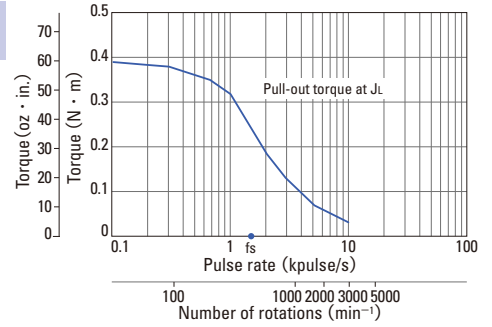

Constant current circuit
Source voltage : DC24V · Operating current : 1A/phase,
2-phase energization (full-step)
 $J_L=[0.94 \times 10^{-4} \text{kg} \cdot \text{m}^2$ (5.14 oz · in²) use the rubber coupling]
fs: Maximum self-start frequency when not loaded

103H5209-5040
103H5209-5010

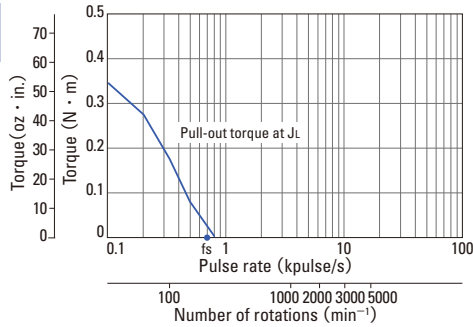

Constant current circuit
Source voltage : DC24V · Operating current : 0.25A/phase,
2-phase energization (full-step)
 $J_L=[0.94 \times 10^{-4} \text{kg} \cdot \text{m}^2$ (5.14 oz · in²) use the rubber coupling]
fs: Maximum self-start frequency when not loaded

103H5209-5140
103H5209-5110

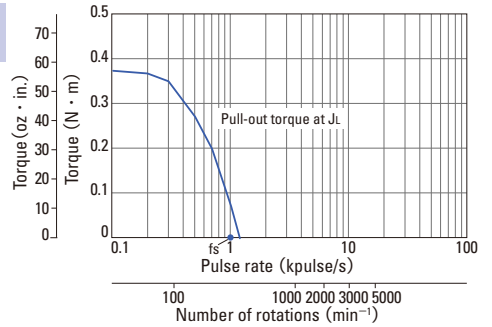

Constant current circuit
Source voltage : DC24V · Operating current : 0.5A/phase,
2-phase energization (full-step)
 $J_L=[0.94 \times 10^{-4} \text{kg} \cdot \text{m}^2$ (5.14 oz · in²) use the rubber coupling]
fs: Maximum self-start frequency when not loaded

103H5209-5240
103H5209-5210

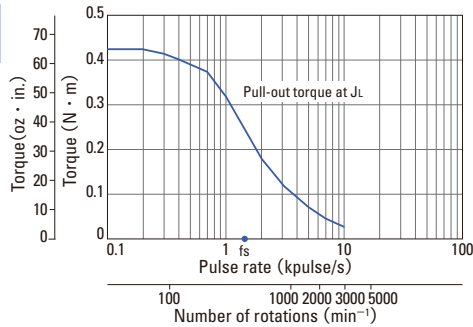

Constant current circuit
Source voltage : DC24V · Operating current : 1A/phase,
2-phase energization (full-step)
 $J_L=[0.94 \times 10^{-4} \text{kg} \cdot \text{m}^2$ (5.14 oz · in²) use the rubber coupling]
fs: Maximum self-start frequency when not loaded

103H5210-5040
103H5210-5010

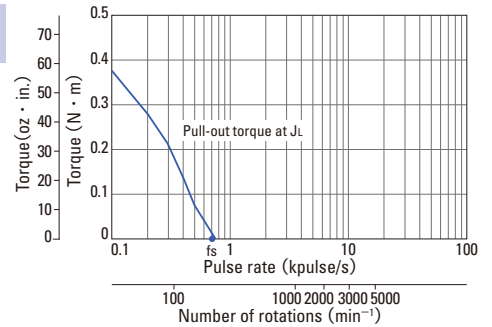

Constant current circuit
Source voltage : DC24V · Operating current : 0.25A/phase,
2-phase energization (full-step)
 $J_L=[0.94 \times 10^{-4} \text{kg} \cdot \text{m}^2$ (5.14 oz · in²) use the rubber coupling]
fs: Maximum self-start frequency when not loaded

103H5210-5140
103H5210-5110

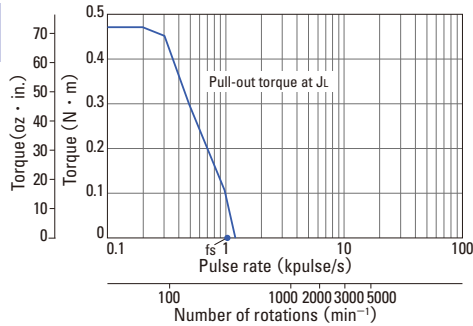

Constant current circuit
Source voltage : DC24V · Operating current : 0.5A/phase,
2-phase energization (full-step)
 $J_L=[0.94 \times 10^{-4} \text{kg} \cdot \text{m}^2$ (5.14 oz · in²) use the rubber coupling]
fs: Maximum self-start frequency when not loaded

103H5210-5240
103H5210-5210

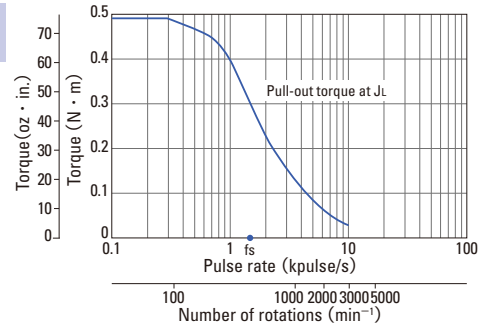

Constant current circuit
Source voltage : DC24V · Operating current : 1A/phase,
2-phase energization (full-step)
 $J_L=[0.94 \times 10^{-4} \text{kg} \cdot \text{m}^2$ (5.14 oz · in²) use the rubber coupling]
fs: Maximum self-start frequency when not loaded



50mm sq. (1.97inch sq.)

1.8° /step

Unipolar winding · Lead wire type
Bipolar winding · Lead wire type ▶ P.36

Unipolar winding · Lead wire type

Model number		Holding torque at 2-phase energization	Rated current	Wiring resistance	Winding inductance	Rotor inertia	Mass (Weight)
Single shaft	Double shafts	[N · m (oz · in) MIN.]	A/phase	Ω /phase	mH/phase	[×10 ⁻⁴ kg · m ² (oz · in ²)]	[kg (lbs)]
103H6701-0140	103H6701-0110	0.28 (39.6)	1	4.3	6.8	0.057 (0.31)	0.35 (0.77)
103H6701-0440	103H6701-0410	0.28 (39.6)	2	1.1	1.6	0.057 (0.31)	0.35 (0.77)
103H6701-0740	103H6701-0710	0.28 (39.6)	3	0.6	0.7	0.057 (0.31)	0.35 (0.77)
103H6703-0140	103H6703-0110	0.49 (69.4)	1	6	13	0.118 (0.65)	0.5 (1.10)
103H6703-0440	103H6703-0410	0.49 (69.4)	2	1.6	3.2	0.118 (0.65)	0.5 (1.10)
103H6703-0740	103H6703-0710	0.49 (69.4)	3	0.83	1.4	0.118 (0.65)	0.5 (1.10)
103H6704-0140	103H6704-0110	0.53 (75.1)	1	6.5	16.5	0.14 (0.77)	0.55 (1.21)
103H6704-0440	103H6704-0410	0.52 (73.6)	2	1.7	3.8	0.14 (0.77)	0.55 (1.21)
103H6704-0740	103H6704-0710	0.53 (75.1)	3	0.9	1.7	0.14 (0.77)	0.55 (1.21)

Characteristics diagram

103H6701-0140
103H6701-0110

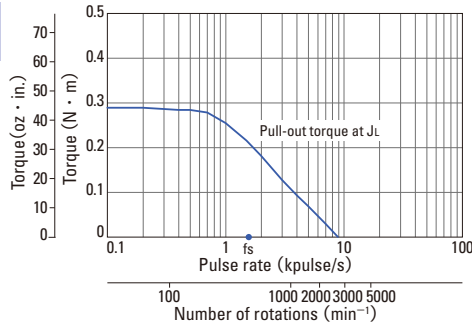

Constant current circuit
Source voltage : DC24V · Operating current : 1A/phase,
2-phase energization (full-step)
 $J_c = [0.94 \times 10^{-4} \text{kg} \cdot \text{m}^2 (5.14 \text{oz} \cdot \text{in}^2) \text{ use the rubber coupling}]$
fs: Maximum self-start frequency when not loaded

103H6701-0440
103H6701-0410

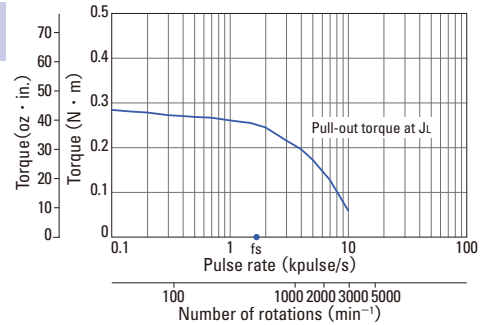

Constant current circuit
Source voltage : DC24V · Operating current : 2A/phase,
2-phase energization (full-step)
 $J_c = [0.94 \times 10^{-4} \text{kg} \cdot \text{m}^2 (5.14 \text{oz} \cdot \text{in}^2) \text{ use the rubber coupling}]$
fs: Maximum self-start frequency when not loaded

103H6701-0740
103H6701-0710

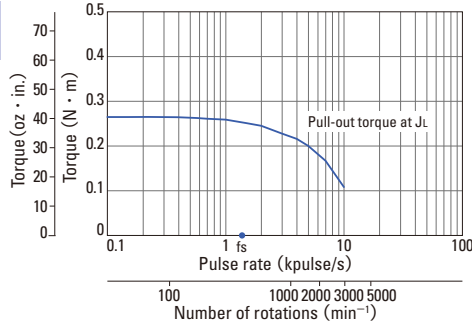

Constant current circuit
Source voltage : DC24V · Operating current : 3A/phase,
2-phase energization (full-step)
 $J_c = [0.94 \times 10^{-4} \text{kg} \cdot \text{m}^2 (5.14 \text{oz} \cdot \text{in}^2) \text{ use the rubber coupling}]$
fs: Maximum self-start frequency when not loaded

103H6703-0140
103H6703-0110

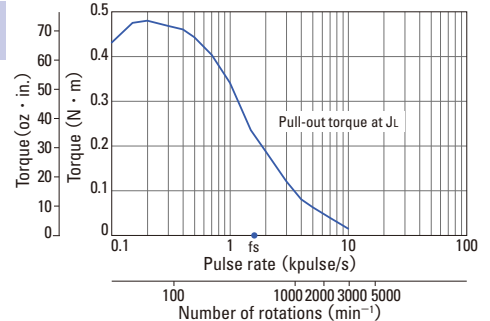

Constant current circuit
Source voltage : DC24V · Operating current : 1A/phase,
2-phase energization (full-step)
 $J_c = [0.94 \times 10^{-4} \text{kg} \cdot \text{m}^2 (5.14 \text{oz} \cdot \text{in}^2) \text{ use the rubber coupling}]$
fs: Maximum self-start frequency when not loaded

Characteristics diagram

103H6703-0440
103H6703-0410

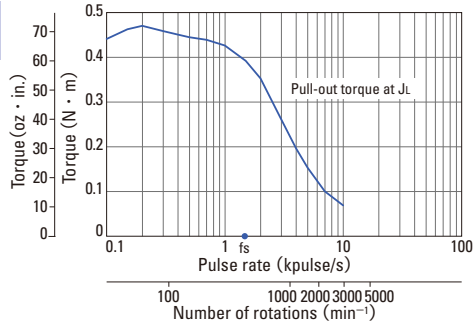

Constant current circuit
Source voltage : DC24V · Operating current : 2A/phase,
2-phase energization (full-step)
 $J_L = [0.94 \times 10^{-4} \text{kg} \cdot \text{m}^2 (5.14 \text{oz} \cdot \text{in}^2) \text{ use the rubber coupling}]$
fs: Maximum self-start frequency when not loaded

103H6703-0740
103H6703-0710

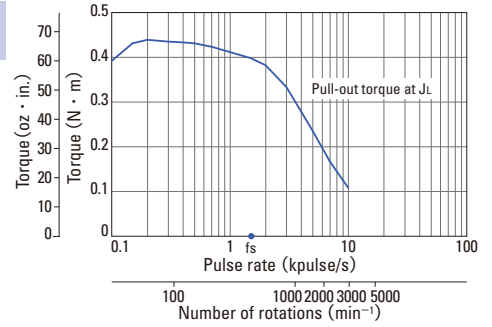

Constant current circuit
Source voltage : DC24V · Operating current : 3A/phase,
2-phase energization (full-step)
 $J_L = [0.94 \times 10^{-4} \text{kg} \cdot \text{m}^2 (5.14 \text{oz} \cdot \text{in}^2) \text{ use the rubber coupling}]$
fs: Maximum self-start frequency when not loaded

103H6704-0140
103H6704-0110

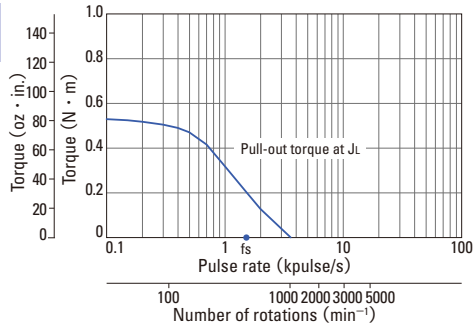

Constant current circuit
Source voltage : DC24V · Operating current : 1A/phase,
2-phase energization (full-step)
 $J_L = [0.94 \times 10^{-4} \text{kg} \cdot \text{m}^2 (5.14 \text{oz} \cdot \text{in}^2) \text{ use the rubber coupling}]$
fs: Maximum self-start frequency when not loaded

103H6704-0440
103H6704-0410

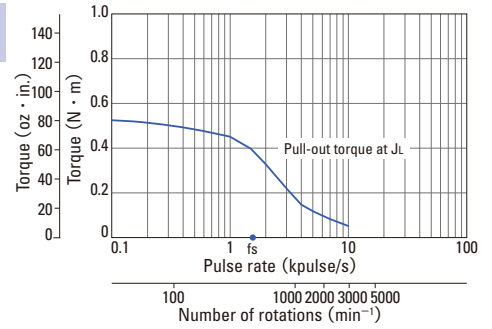

Constant current circuit
Source voltage : DC24V · Operating current : 2A/phase,
2-phase energization (full-step)
 $J_L = [0.94 \times 10^{-4} \text{kg} \cdot \text{m}^2 (5.14 \text{oz} \cdot \text{in}^2) \text{ use the rubber coupling}]$
fs: Maximum self-start frequency when not loaded

103H6704-0740
103H6704-0710

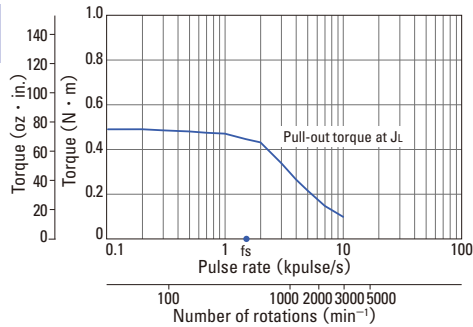

Constant current circuit
Source voltage : DC24V · Operating current : 3A/phase,
2-phase energization (full-step)
 $J_L = [0.94 \times 10^{-4} \text{kg} \cdot \text{m}^2 (5.14 \text{oz} \cdot \text{in}^2) \text{ use the rubber coupling}]$
fs: Maximum self-start frequency when not loaded



50mm sq. (1.97inch sq.)

1.8° /step

Unipolar winding · Lead wire type ▶ P.34

Bipolar winding · Lead wire type

Bipolar winding · Lead wire type

Model number		Holding torque at 2-phase energization	Rated current	Wiring resistance	Winding inductance	Rotor inertia	Mass (Weight)
Single shaft	Double shafts	[N · m (oz · in) MIN.]	A/phase	Ω /phase	mH/phase	[×10 ⁻⁴ kg · m ² (oz · in ²)]	[kg (lbs)]
103H6701-5040	103H6701-5010	0.28 (39.6)	2	0.6	1.6	0.057 (0.31)	0.35 (0.77)
103H6703-5040	103H6703-5010	0.49 (69.4)	2	0.8	3.2	0.118 (0.65)	0.5 (1.10)
103H6704-5040	103H6704-5010	0.52 (73.6)	2	0.9	3.8	0.14 (0.77)	0.55 (1.21)

Characteristics diagram

103H6701-5040
103H6701-5010

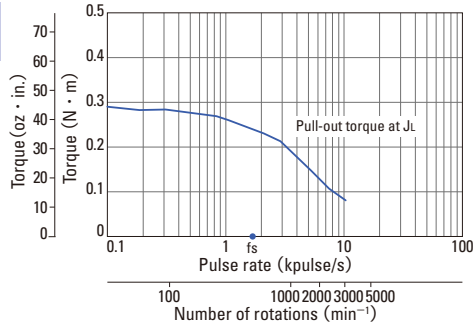

Constant current circuit
Source voltage : DC24V · Operating current : 2A/phase,
2-phase energization (full-step)
 $J_t = [0.94 \times 10^{-4} \text{kg} \cdot \text{m}^2 (5.14 \text{oz} \cdot \text{in}^2) \text{ use the rubber coupling}]$
fs: Maximum self-start frequency when not loaded

103H6703-5040
103H6703-5010

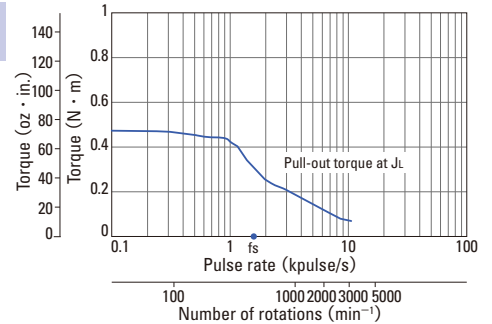

Constant current circuit
Source voltage : DC24V · Operating current : 2A/phase,
2-phase energization (full-step)
 $J_t = [0.94 \times 10^{-4} \text{kg} \cdot \text{m}^2 (5.14 \text{oz} \cdot \text{in}^2) \text{ use the rubber coupling}]$
fs: Maximum self-start frequency when not loaded

103H6704-5040
103H6704-5010

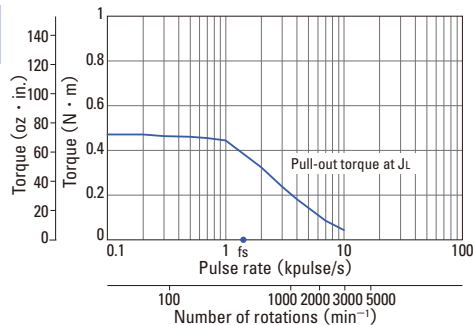

Constant current circuit
Source voltage : DC24V · Operating current : 2A/phase,
2-phase energization (full-step)
 $J_t = [0.94 \times 10^{-4} \text{kg} \cdot \text{m}^2 (5.14 \text{oz} \cdot \text{in}^2) \text{ use the rubber coupling}]$
fs: Maximum self-start frequency when not loaded



50mm sq. (1.97inch sq.)

1.8° /step **Slim form**

Bipolar winding · Lead wire type

Bipolar winding · Lead wire type

Model number		Holding torque at 2-phase energization	Rated current	Wiring resistance	Winding inductance	Rotor inertia	Mass (Weight)
Single shaft	Double shafts	[N · m (oz · in) MIN.]	A/phase	Ω /phase	mH/phase	[×10 ⁻⁴ kg · m ² (oz · in ²)]	[kg (lbs)]
SS2501-8040	SS2501-8010	0.1 (14.16)	1	4.5	2	0.026 (0.142)	0.09 (0.20)
SS2502-8040	SS2502-8010	0.215 (30.44)	1	5.9	3.2	0.049 (0.268)	0.15 (0.33)

Characteristics diagram

SS2501-8040
SS2501-8010

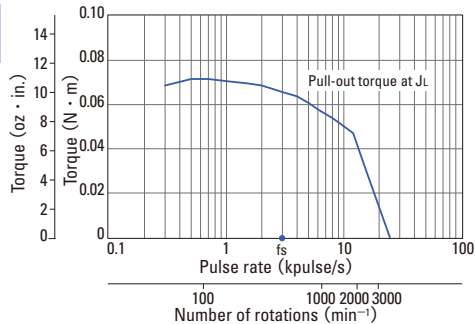

Constant current circuit
Source voltage : DC24V · operating current : 1A/phase,
1-2-phase energization (half-step)
 $J_L = [0.01 \times 10^{-4} \text{kg} \cdot \text{m}^2 (1.80 \text{oz} \cdot \text{in}^2) \text{ pulley balancer method}]$
fs: Maximum self-start frequency when not loaded

SS2502-8040
SS2502-8010

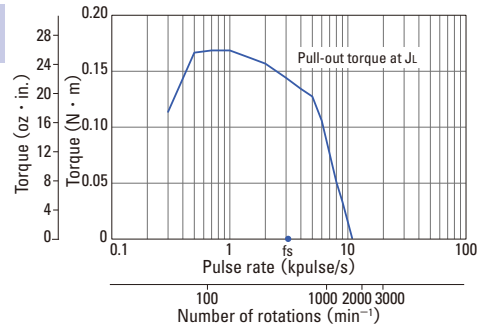

Constant current circuit
Source voltage : DC24V · operating current : 1A/phase,
1-2-phase energization (half-step)
 $J_L = [0.01 \times 10^{-4} \text{kg} \cdot \text{m}^2 (1.80 \text{oz} \cdot \text{in}^2) \text{ pulley balancer method}]$
fs: Maximum self-start frequency when not loaded



56mm sq. (2.20inch sq.)

1.8° /step

Unipolar winding · Lead wire type
Bipolar winding · Lead wire type ▶ P.40

Unipolar winding · Lead wire type

Model number		Holding torque at 2-phase energization	Rated current	Wiring resistance	Winding inductance	Rotor inertia	Mass (Weight)
Single shaft	Double shafts	[N · m (oz · in) MIN.]	A/phase	Ω /phase	mH/phase	[×10 ⁻⁴ kg · m ² (oz · in ²)]	[kg (lbs)]
103H7121-0140	103H7121-0110	0.39 (55.2)	1	4.8	8	0.1 (0.55)	0.47 (1.04)
103H7121-0440	103H7121-0410	0.39 (55.2)	2	1.25	1.9	0.1 (0.55)	0.47 (1.04)
103H7121-0740	103H7121-0710	0.39 (55.2)	3	0.6	0.8	0.1 (0.55)	0.47 (1.04)
103H7123-0140	103H7123-0110	0.83 (117.)	1	6.7	15	0.21 (1.15)	0.65 (1.43)
103H7123-0440	103H7123-0410	0.83 (117.5)	2	1.6	3.8	0.21 (1.15)	0.65 (1.43)
103H7123-0740	103H7123-0710	0.78 (110.5)	3	0.77	1.58	0.21 (1.15)	0.65 (1.43)
103H7124-0140	103H7124-0110	0.98 (138.8)	1	7	14.5	0.245 (1.34)	0.8 (1.76)
103H7124-0440	103H7124-0410	0.98 (138.8)	2	1.7	3.1	0.245 (1.34)	0.8 (1.76)
103H7124-0740	103H7124-0710	0.98 (138.8)	3	0.74	1.4	0.245 (1.34)	0.8 (1.76)
103H7126-0140	103H7126-0110	1.27 (179.8)	1	8.6	19	0.36 (1.97)	0.98 (2.16)
103H7126-0440	103H7126-0410	1.27 (179.8)	2	2	4.5	0.36 (1.97)	0.98 (2.16)
103H7126-0740	103H7126-0710	1.27 (179.8)	3	0.9	2.2	0.36 (1.97)	0.98 (2.16)

Characteristics diagram

103H7121-0140
103H7121-0110

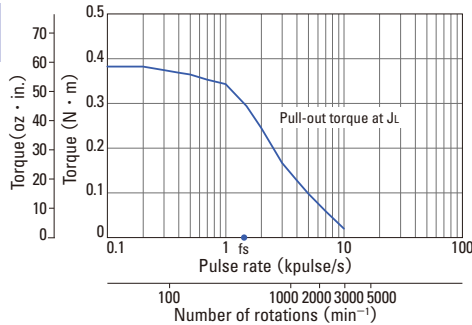

Constant current circuit
Source voltage : DC24V · Operating current : 1A/phase,
2-phase energization (full-step)
 $J_1 = [0.94 \times 10^{-4} \text{kg} \cdot \text{m}^2 (5.14 \text{oz} \cdot \text{in}^2)]$ use the rubber coupling]
fs: Maximum self-start frequency when not loaded

103H7121-0440
103H7121-0410

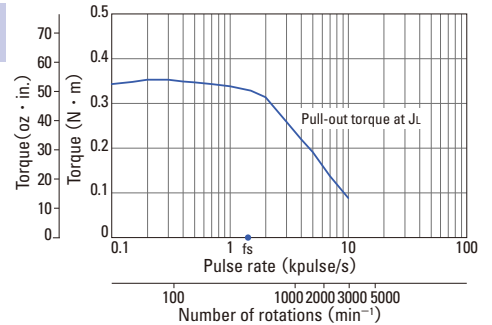

Constant current circuit
Source voltage : DC24V · Operating current : 2A/phase,
2-phase energization (full-step)
 $J_1 = [0.94 \times 10^{-4} \text{kg} \cdot \text{m}^2 (5.14 \text{oz} \cdot \text{in}^2)]$ use the rubber coupling]
fs: Maximum self-start frequency when not loaded

103H7121-0740
103H7121-0710

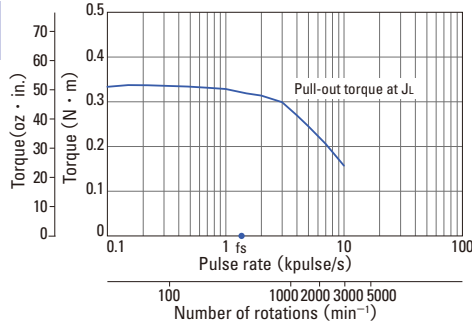

Constant current circuit
Source voltage : DC24V · Operating current : 3A/phase,
2-phase energization (full-step)
 $J_1 = [0.94 \times 10^{-4} \text{kg} \cdot \text{m}^2 (5.14 \text{oz} \cdot \text{in}^2)]$ use the rubber coupling]
fs: Maximum self-start frequency when not loaded

103H7123-0140
103H7123-0110

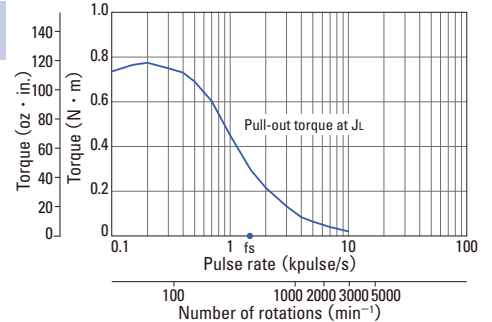

Constant current circuit
Source voltage : DC24V · Operating current : 1A/phase,
2-phase energization (full-step)
 $J_1 = [0.94 \times 10^{-4} \text{kg} \cdot \text{m}^2 (5.14 \text{oz} \cdot \text{in}^2)]$ use the rubber coupling]
fs: Maximum self-start frequency when not loaded

Characteristics diagram

103H7123-0440
103H7123-0410

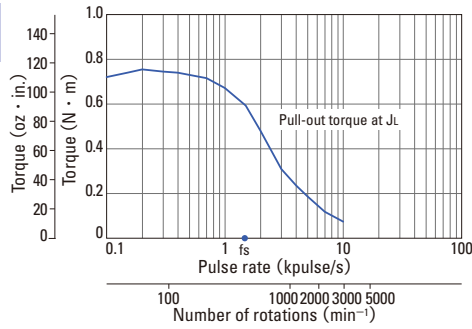

Constant current circuit
Source voltage : DC24V · Operating current : 2A/phase,
2-phase energization (full-step)
 $J_L = [0.94 \times 10^{-4} \text{kg} \cdot \text{m}^2 (5.14 \text{oz} \cdot \text{in}^2) \text{ use the rubber coupling}]$
 f_s : Maximum self-start frequency when not loaded

103H7123-0740
103H7123-0710

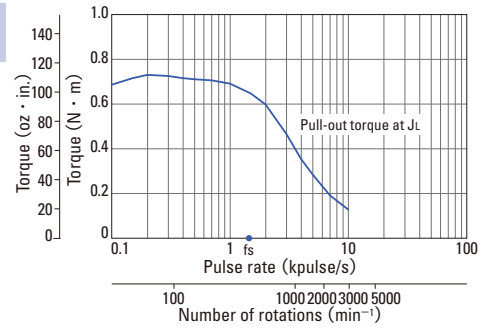

Constant current circuit
Source voltage : DC24V · Operating current : 3A/phase,
2-phase energization (full-step)
 $J_L = [0.94 \times 10^{-4} \text{kg} \cdot \text{m}^2 (5.14 \text{oz} \cdot \text{in}^2) \text{ use the rubber coupling}]$
 f_s : Maximum self-start frequency when not loaded

103H7124-0140
103H7124-0110

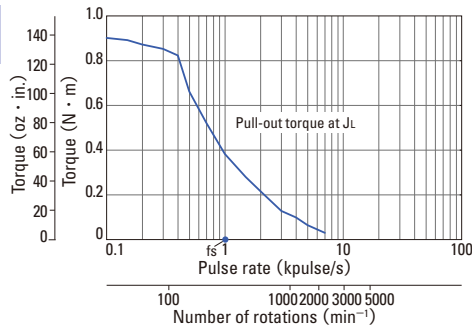

Constant current circuit
Source voltage : DC24V · Operating current : 1A/phase,
2-phase energization (full-step)
 $J_L = [2.6 \times 10^{-4} \text{kg} \cdot \text{m}^2 (14.22 \text{oz} \cdot \text{in}^2) \text{ use the rubber coupling}]$
 f_s : Maximum self-start frequency when not loaded

103H7124-0440
103H7124-0410

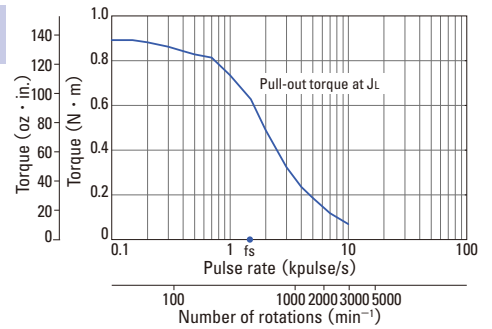

Constant current circuit
Source voltage : DC24V · Operating current : 2A/phase,
2-phase energization (full-step)
 $J_L = [2.6 \times 10^{-4} \text{kg} \cdot \text{m}^2 (14.22 \text{oz} \cdot \text{in}^2) \text{ use the rubber coupling}]$
 f_s : Maximum self-start frequency when not loaded

103H7124-0740
103H7124-0710

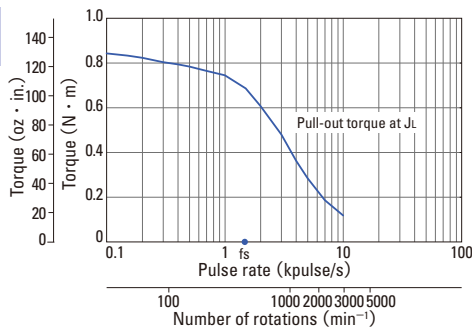

Constant current circuit
Source voltage : DC24V · Operating current : 3A/phase,
2-phase energization (full-step)
 $J_L = [2.6 \times 10^{-4} \text{kg} \cdot \text{m}^2 (14.22 \text{oz} \cdot \text{in}^2) \text{ use the rubber coupling}]$
 f_s : Maximum self-start frequency when not loaded

103H7126-0140
103H7126-0110

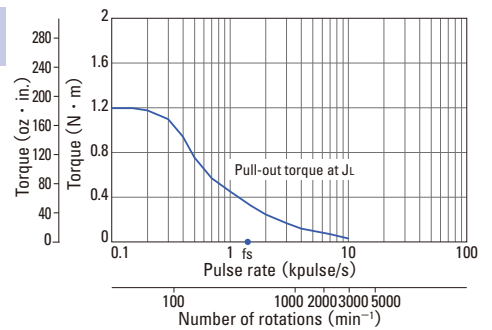

Constant current circuit
Source voltage : DC24V · Operating current : 1A/phase,
2-phase energization (full-step)
 $J_L = [2.6 \times 10^{-4} \text{kg} \cdot \text{m}^2 (14.22 \text{oz} \cdot \text{in}^2) \text{ use the rubber coupling}]$
 f_s : Maximum self-start frequency when not loaded

103H7126-0440
103H7126-0410

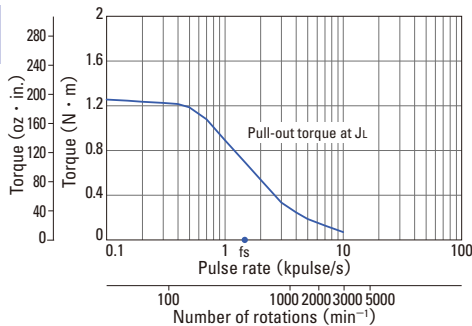

Constant current circuit
Source voltage : DC24V · Operating current : 2A/phase,
2-phase energization (full-step)
 $J_L = [2.6 \times 10^{-4} \text{kg} \cdot \text{m}^2 (14.22 \text{oz} \cdot \text{in}^2) \text{ use the rubber coupling}]$
 f_s : Maximum self-start frequency when not loaded

103H7126-0740
103H7126-0710

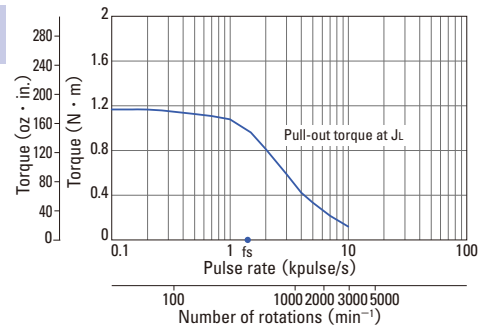

Constant current circuit
Source voltage : DC24V · Operating current : 3A/phase,
2-phase energization (full-step)
 $J_L = [2.6 \times 10^{-4} \text{kg} \cdot \text{m}^2 (14.22 \text{oz} \cdot \text{in}^2) \text{ use the rubber coupling}]$
 f_s : Maximum self-start frequency when not loaded



56mm sq. (2.20inch sq.)

1.8° /step

Unipolar winding · Lead wire type ▶ P.38

Bipolar winding · Lead wire type

Bipolar winding · Lead wire type

Model number		Holding torque at 2-phase energization	Rated current	Wiring resistance	Winding inductance	Rotor inertia	Mass (Weight)
Single shaft	Double shafts	[N · m (oz · in) MIN.]	A/phase	Ω /phase	mH/phase	[×10 ⁻⁴ kg · m ² (oz · in ²)]	[kg (lbs)]
103H7121-5640	103H7121-5610	0.55 (77.9)	1	4.3	14.5	0.1 (0.55)	0.47 (1.04)
103H7121-5740	103H7121-5710	0.55 (77.9)	2	1.1	3.7	0.1 (0.55)	0.47 (1.04)
103H7121-5840	103H7121-5810	0.55 (77.9)	3	0.54	1.74	0.1 (0.55)	0.47 (1.04)
103H7123-5640	103H7123-5610	1.0 (141.6)	1	5.7	29.4	0.21 (1.15)	0.65 (1.43)
103H7123-5740	103H7123-5710	1.0 (141.6)	2	1.5	7.5	0.21 (1.15)	0.65 (1.43)
103H7123-5840	103H7123-5810	1.0 (141.6)	3	0.7	3.5	0.21 (1.15)	0.65 (1.43)
103H7126-5640	103H7126-5610	1.6 (226.6)	1	7.7	34.6	0.36 (1.97)	0.98 (2.16)
103H7126-5740	103H7126-5710	1.6 (226.6)	2	2	9.1	0.36 (1.97)	0.98 (2.16)
103H7126-5840	103H7126-5810	1.6 (226.6)	3	0.94	4	0.36 (1.97)	0.98 (2.16)
103H7128-5640	103H7128-5610	2.0 (283.2)	1	8.9	40.1	0.49 (2.68)	1.3 (2.87)
103H7128-5740	103H7128-5710	2.0 (283.2)	2	2.3	10.4	0.49 (2.68)	1.3 (2.87)
103H7128-5840	103H7128-5810	2.0 (283.2)	3	1.03	4.3	0.49 (2.68)	1.3 (2.87)

Characteristics diagram

103H7121-5640
103H7121-5610

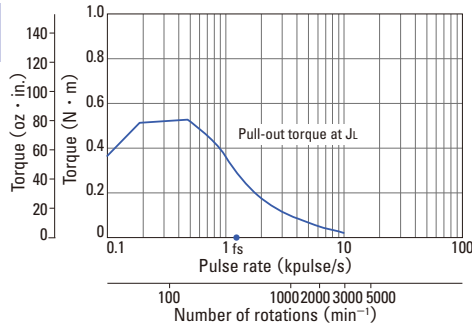

Constant current circuit
Source voltage : DC24V · Operating current : 1A/phase,
2-phase energization (full-step)
 $J_L = [0.94 \times 10^{-4} \text{kg} \cdot \text{m}^2 (5.14 \text{oz} \cdot \text{in}^2)]$ use the rubber coupling]
fs: Maximum self-start frequency when not loaded

103H7121-5740
103H7121-5710

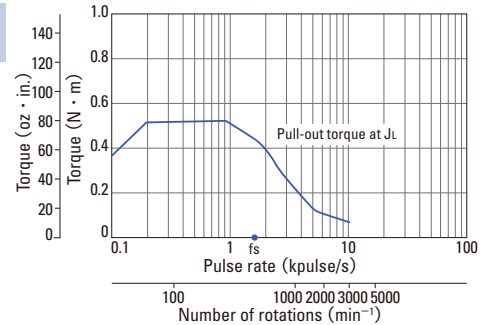

Constant current circuit
Source voltage : DC24V · Operating current : 2A/phase,
2-phase energization (full-step)
 $J_L = [0.94 \times 10^{-4} \text{kg} \cdot \text{m}^2 (5.14 \text{oz} \cdot \text{in}^2)]$ use the rubber coupling]
fs: Maximum self-start frequency when not loaded

103H7121-5840
103H7121-5810

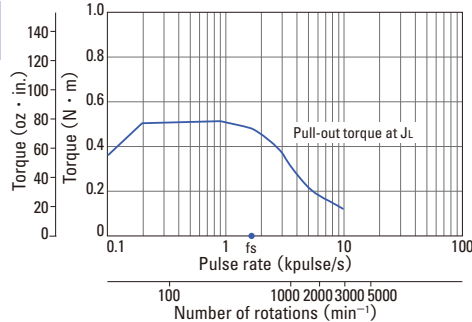

Constant current circuit
Source voltage : DC24V · Operating current : 3A/phase,
2-phase energization (full-step)
 $J_L = [0.94 \times 10^{-4} \text{kg} \cdot \text{m}^2 (5.14 \text{oz} \cdot \text{in}^2)]$ use the rubber coupling]
fs: Maximum self-start frequency when not loaded

103H7123-5640
103H7123-5610

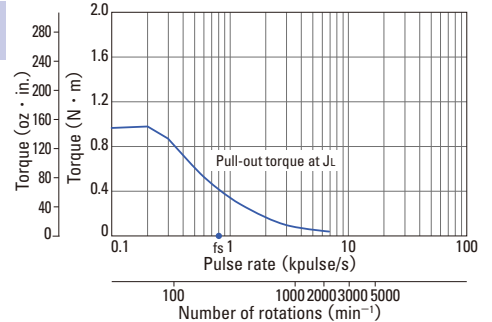

Constant current circuit
Source voltage : DC24V · Operating current : 1A/phase,
2-phase energization (full-step)
 $J_L = [2.6 \times 10^{-4} \text{kg} \cdot \text{m}^2 (14.22 \text{oz} \cdot \text{in}^2)]$ use the rubber coupling]
fs: Maximum self-start frequency when not loaded

Characteristics diagram

103H7123-5740
103H7123-5710

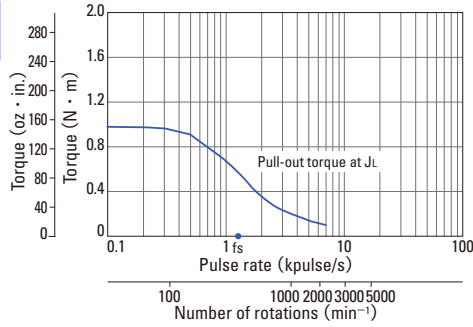

Constant current circuit
Source voltage : DC24V · operating current : 2A/phase,
2-phase energization (full-step)
 $J_L = [2.6 \times 10^{-4} \text{kg} \cdot \text{m}^2 (14.22 \text{oz} \cdot \text{in}^2)]$ use the rubber coupling]
fs: Maximum self-start frequency when not loaded

103H7123-5840
103H7123-5810

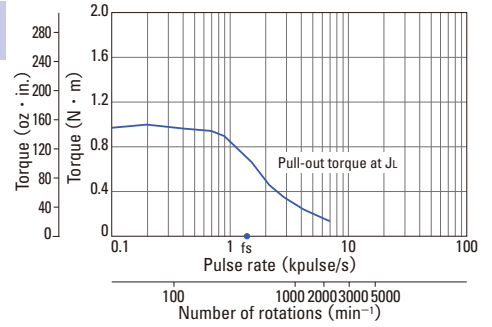

Constant current circuit
Source voltage : DC24V · Operating current : 3A/phase,
2-phase energization (full-step)
 $J_L = [2.6 \times 10^{-4} \text{kg} \cdot \text{m}^2 (14.22 \text{oz} \cdot \text{in}^2)]$ use the rubber coupling]
fs: Maximum self-start frequency when not loaded

103H7126-5640
103H7126-5610

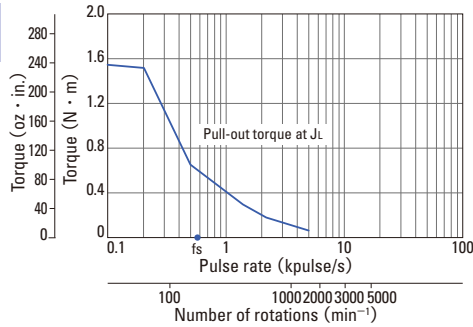

Constant current circuit
Source voltage : DC24V · Operating current : 1A/phase,
2-phase energization (full-step)
 $J_L = [2.6 \times 10^{-4} \text{kg} \cdot \text{m}^2 (14.22 \text{oz} \cdot \text{in}^2)]$ use the rubber coupling]
fs: Maximum self-start frequency when not loaded

103H7126-5740
103H7126-5710

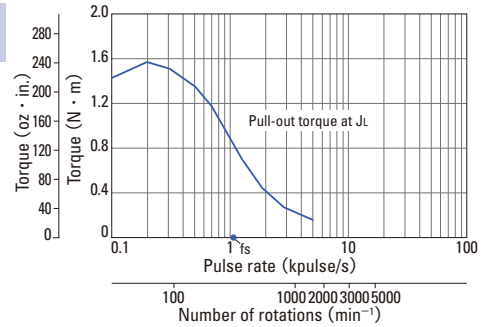

Constant current circuit
Source voltage : DC24V · Operating current : 2A/phase,
2-phase energization (full-step)
 $J_L = [2.6 \times 10^{-4} \text{kg} \cdot \text{m}^2 (14.22 \text{oz} \cdot \text{in}^2)]$ use the rubber coupling]
fs: Maximum self-start frequency when not loaded

103H7126-5840
103H7126-5810

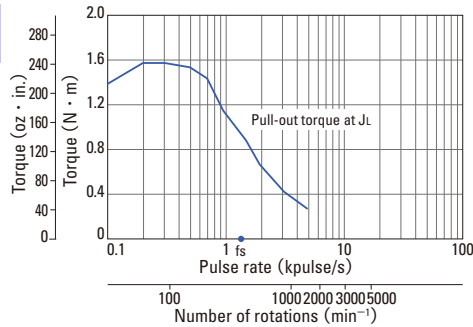

Constant current circuit
Source voltage : DC24V · Operating current : 3A/phase,
2-phase energization (full-step)
 $J_L = [2.6 \times 10^{-4} \text{kg} \cdot \text{m}^2 (14.22 \text{oz} \cdot \text{in}^2)]$ use the rubber coupling]
fs: Maximum self-start frequency when not loaded

103H7128-5640
103H7128-5610

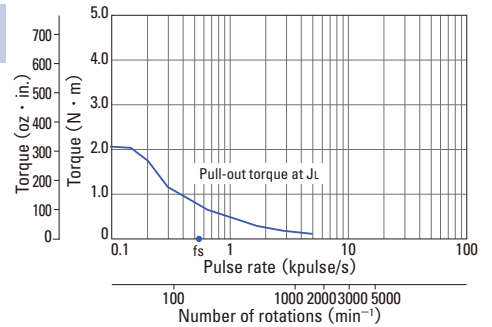

Constant current circuit
Source voltage : DC24V · Operating current : 1A/phase,
2-phase energization (full-step)
 $J_L = [7.4 \times 10^{-4} \text{kg} \cdot \text{m}^2 (40.46 \text{oz} \cdot \text{in}^2)]$ use the rubber coupling]
fs: Maximum self-start frequency when not loaded

103H7128-5740
103H7128-5710

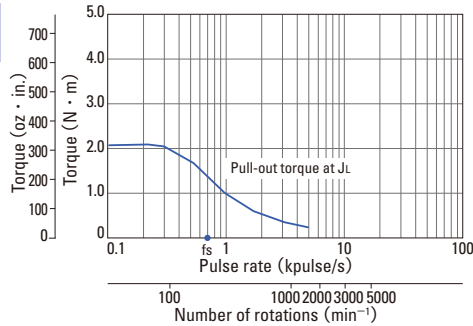

Constant current circuit
Source voltage : DC24V · Operating current : 2A/phase,
2-phase energization (full-step)
 $J_L = [7.4 \times 10^{-4} \text{kg} \cdot \text{m}^2 (40.46 \text{oz} \cdot \text{in}^2)]$ use the rubber coupling]
fs: Maximum self-start frequency when not loaded

103H7128-5840
103H7128-5810

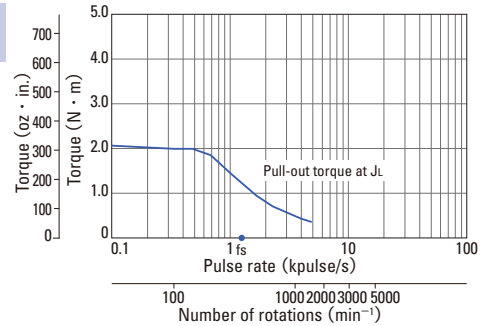

Constant current circuit
Source voltage : DC24V · Operating current : 3A/phase,
2-phase energization (full-step)
 $J_L = [7.4 \times 10^{-4} \text{kg} \cdot \text{m}^2 (40.46 \text{oz} \cdot \text{in}^2)]$ use the rubber coupling]
fs: Maximum self-start frequency when not loaded



60mm sq. (2.36inch sq.)

0.9° /step

Unipolar winding · Lead wire type
Bipolar winding · Lead wire type

Unipolar winding · Lead wire type

Model number		Holding torque at 2-phase energization	Rated current	Wiring resistance	Winding inductance	Rotor inertia	Mass (Weight)
Single shaft	Double shafts	[N · m (oz · in) MIN.]	A/phase	Ω /phase	mH/phase	[×10 ⁻⁴ kg · m ² (oz · in ²)]	[kg (lbs)]
SH1601-0440	SH1601-0410	0.57 (80.71)	2	1.35	2	0.24 (1.312)	0.55 (1.21)
SH1602-0440	SH1602-0410	1.1 (155.77)	2	1.8	3.5	0.4 (2.187)	0.8 (1.76)
SH1603-0440	SH1603-0410	1.7 (240.74)	2	2.3	4.5	0.75 (4.101)	1.2 (2.64)

Characteristics diagram

SH1601-0440
SH1601-0410

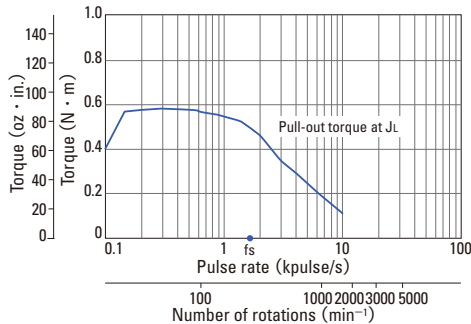

Constant current circuit
Source voltage : DC24V · Operating current : 2A/phase,
2-phase energization (full-step)
 $J_L = [0.94 \times 10^{-4} \text{kg} \cdot \text{m}^2 (5.14 \text{oz} \cdot \text{in}^2)]$ use the rubber coupling]
fs: Maximum self-start frequency when not loaded

SH1602-0440
SH1602-0410

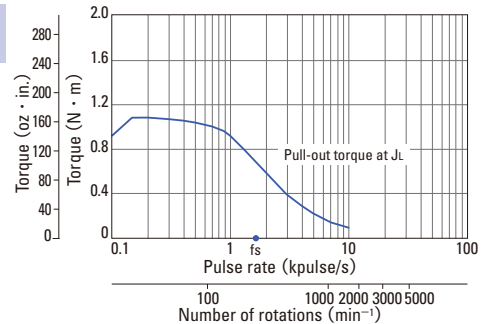

Constant current circuit
Source voltage : DC24V · Operating current : 2A/phase,
2-phase energization (full-step)
 $J_L = [2.6 \times 10^{-4} \text{kg} \cdot \text{m}^2 (14.22 \text{oz} \cdot \text{in}^2)]$ use the rubber coupling]
fs: Maximum self-start frequency when not loaded

SH1603-0440
SH1603-0410

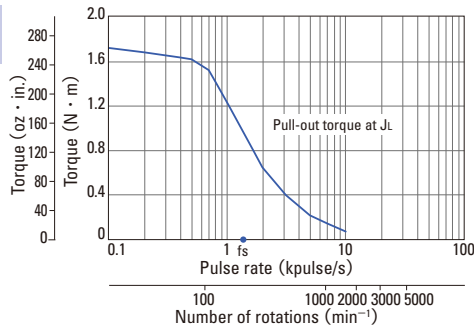

Constant current circuit
Source voltage : DC24V · Operating current : 2A/phase,
2-phase energization (full-step)
 $J_L = [7.4 \times 10^{-4} \text{kg} \cdot \text{m}^2 (40.46 \text{oz} \cdot \text{in}^2)]$ use the rubber coupling]
fs: Maximum self-start frequency when not loaded

Bipolar winding • Lead wire type

Model number		Holding torque at 2-phase energization	Rated current	Wiring resistance	Winding inductance	Rotor inertia	Mass (Weight)
Single shaft	Double shafts	[N · m (oz · in) MIN.]	A/phase	Ω /phase	mH/phase	[×10 ⁻⁴ kg · m ² (oz · in ²)]	[kg (lbs)]
SH1601-5240	SH1601-5210	0.69 (97.7)	2	1.2	3.5	0.24 (1.31)	0.55 (1.21)
SH1602-5240	SH1602-5210	1.28 (181.2)	2	1.65	6.1	0.4 (2.19)	0.8 (1.76)
SH1603-5240	SH1603-5210	2.15 (304.4)	2	2.3	8.8	0.75 (4.10)	1.2 (2.65)

Characteristics diagram

**SH1601-5240
SH1601-5210**

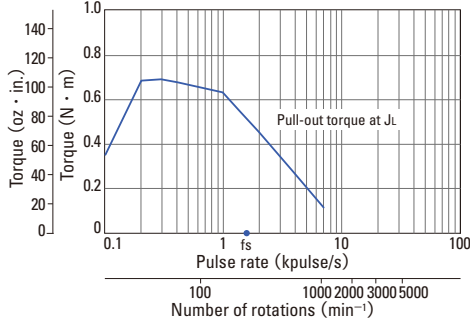

Constant current circuit
 Source voltage : DC24V · Operating current : 2A/phase,
 2-phase energization (full-step)
 $J_L = [0.94 \times 10^{-4} \text{kg} \cdot \text{m}^2 (5.14 \text{oz} \cdot \text{in}^2)$ use the rubber coupling]
 fs: Maximum self-start frequency when not loaded

**SH1602-5240
SH1602-5210**

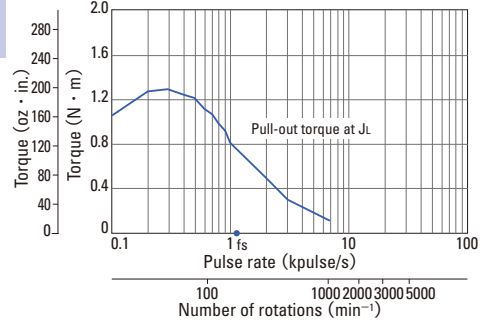

Constant current circuit
 Source voltage : DC24V · Operating current : 2A/phase,
 2-phase energization (full-step)
 $J_L = [2.6 \times 10^{-4} \text{kg} \cdot \text{m}^2 (14.22 \text{oz} \cdot \text{in}^2)$ use the rubber coupling]
 fs: Maximum self-start frequency when not loaded

**SH1603-5240
SH1603-5210**

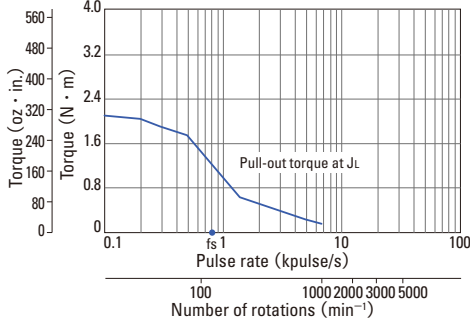

Constant current circuit
 Source voltage : DC24V · Operating current : 2A/phase,
 2-phase energization (full-step)
 $J_L = [7.4 \times 10^{-4} \text{kg} \cdot \text{m}^2 (40.46 \text{oz} \cdot \text{in}^2)$ use the rubber coupling]
 fs: Maximum self-start frequency when not loaded



60mm sq. (2.36inch sq.)

1.8° /step

Unipolar winding · Connector type

Unipolar winding · Lead wire type Dimensions for attaching NEMA23 are interchangeable (47.14mm-pitch)

Bipolar winding · Connector type ▶ P.46

Bipolar winding · Lead wire type Dimensions for attaching NEMA23 are interchangeable (47.14mm-pitch) ▶ P.46

Unipolar winding · Connector type

Model number		Holding torque at 2-phase energization [N · m (oz · in) MIN.]	Rated current A/phase	Wiring resistance Ω /phase	Winding inductance mH/phase	Rotor inertia [×10 ⁻⁴ kg · m ² (oz · in ²)]	Mass (Weight) [kg (lbs)]
Single shaft	Double shafts						
103H7821-0140	103H7821-0110	0.78 (110.5)	1	5.7	8.3	0.275 (1.50)	0.6 (1.32)
103H7821-0440	103H7821-0410	0.78 (110.5)	2	1.5	2	0.275 (1.50)	0.6 (1.32)
103H7821-0740	103H7821-0710	0.78 (110.5)	3	0.68	0.8	0.275 (1.50)	0.6 (1.32)
103H7822-0140	103H7822-0110	1.17 (165.7)	1	6.9	14	0.4 (2.19)	0.77 (1.70)
103H7822-0440	103H7822-0410	1.17 (165.7)	2	1.8	3.6	0.4 (2.19)	0.77 (1.70)
103H7822-0740	103H7822-0710	1.17 (165.7)	3	0.8	1.38	0.4 (2.19)	0.77 (1.70)
103H7823-0140	103H7823-0110	2.1 (297.4)	1	10	21.7	0.84 (4.59)	1.34 (2.95)
103H7823-0440	103H7823-0410	2.1 (297.4)	2	2.7	5.6	0.84 (4.59)	1.34 (2.95)
103H7823-0740	103H7823-0710	2.1 (297.4)	3	1.25	2.4	0.84 (4.59)	1.34 (2.95)

Motor cable : Model No. 4837798-1

Unipolar winding · Lead wire type Dimensions for attaching NEMA23 are interchangeable (47.14mm-pitch)

Model number		Holding torque at 2-phase energization [N · m (oz · in) MIN.]	Rated current A/phase	Wiring resistance Ω /phase	Winding inductance mH/phase	Rotor inertia [×10 ⁻⁴ kg · m ² (oz · in ²)]	Mass (Weight) [kg (lbs)]
Single shaft	Double shafts						
103H7821-0160	103H7821-0130	0.78 (110.5)	1	5.7	8.3	0.275 (1.50)	0.6 (1.32)
103H7821-0460	103H7821-0430	0.78 (110.5)	2	1.5	2	0.275 (1.50)	0.6 (1.32)
103H7821-0760	103H7821-0730	0.78 (110.5)	3	0.68	0.8	0.275 (1.50)	0.6 (1.32)
103H7822-0160	103H7822-0130	1.17 (165.7)	1	6.9	14	0.4 (2.19)	0.77 (1.70)
103H7822-0460	103H7822-0430	1.17 (165.7)	2	1.8	3.6	0.4 (2.19)	0.77 (1.70)
103H7822-0760	103H7822-0730	1.17 (165.7)	3	0.8	1.38	0.4 (2.19)	0.77 (1.70)
103H7823-0160	103H7823-0130	2.1 (297.4)	1	10	21.7	0.84 (4.59)	1.34 (2.95)
103H7823-0460	103H7823-0430	2.1 (297.4)	2	2.7	5.6	0.84 (4.59)	1.34 (2.95)
103H7823-0760	103H7823-0730	2.1 (297.4)	3	1.25	2.4	0.84 (4.59)	1.34 (2.95)

Characteristics diagram

103H7821-0140
103H7821-0110

103H7821-0160
103H7821-0130

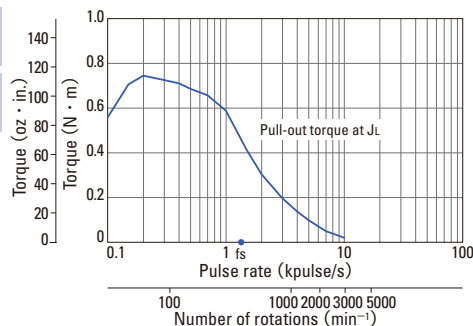

Constant current circuit
Source voltage : DC24V · Operating current : 1A/phase,
2-phase energization (full-step)
J_c=[0.94 × 10⁻⁴kg · m² (5.14 oz · in²) use the rubber coupling]
fs: Maximum self-start frequency when not loaded

103H7821-0440
103H7821-0410

103H7821-0460
103H7821-0430

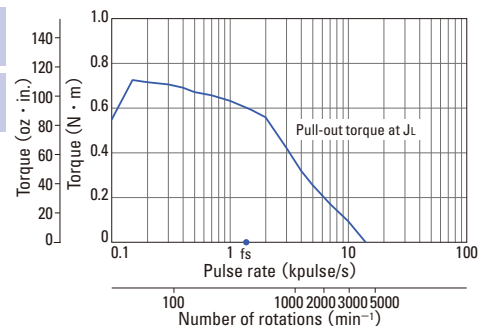

Constant current circuit
Source voltage : DC24V · Operating current : 2A/phase,
2-phase energization (full-step)
J_c=[0.94 × 10⁻⁴kg · m² (5.14 oz · in²) use the rubber coupling]
fs: Maximum self-start frequency when not loaded

Characteristics diagram

103H7821-0740
103H7821-0710

103H7821-0760
103H7821-0730

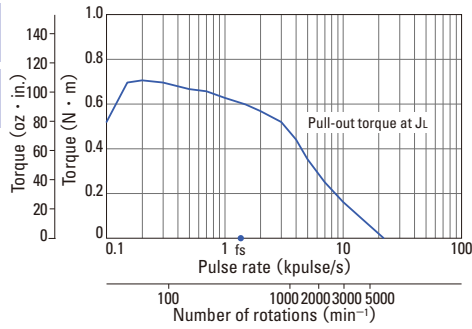

Constant current circuit
Source voltage : DC24V · Operating current : 3A/phase,
2-phase energization (full-step)
 $J_L=0.94 \times 10^{-4} \text{kg} \cdot \text{m}^2$ (5.14 oz · in²) use the rubber coupling]
fs: Maximum self-start frequency when not loaded

103H7822-0140
103H7822-0110

103H7822-0160
103H7822-0130

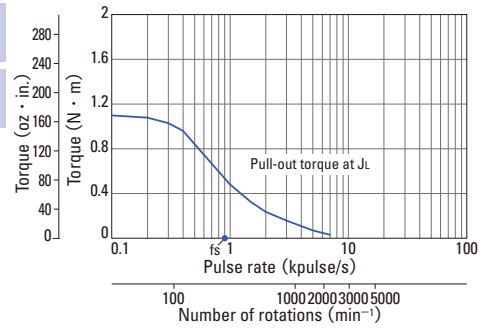

Constant current circuit
Source voltage : DC24V · Operating current : 1A/phase,
2-phase energization (full-step)
 $J_L=7.4 \times 10^{-4} \text{kg} \cdot \text{m}^2$ (40.46 oz · in²) use the rubber coupling]
fs: Maximum self-start frequency when not loaded

103H7822-0440
103H7822-0410

103H7822-0460
103H7822-0430

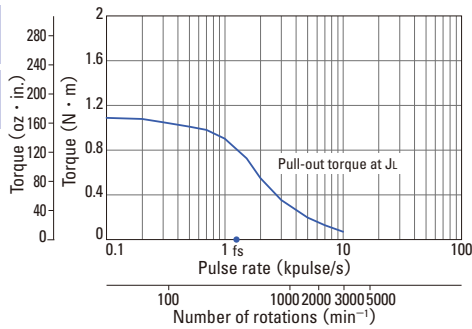

Constant current circuit
Source voltage : DC24V · Operating current : 2A/phase,
2-phase energization (full-step)
 $J_L=7.4 \times 10^{-4} \text{kg} \cdot \text{m}^2$ (40.46 oz · in²) use the rubber coupling]
fs: Maximum self-start frequency when not loaded

103H7822-0740
103H7822-0710

103H7822-0760
103H7822-0730

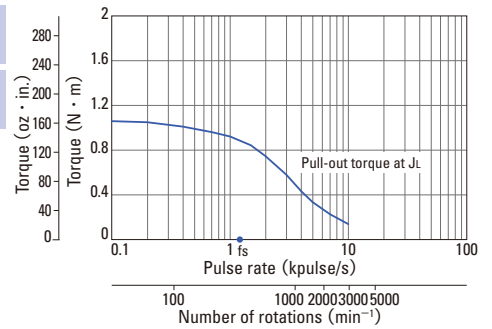

Constant current circuit
Source voltage : DC24V · Operating current : 3A/phase,
2-phase energization (full-step)
 $J_L=7.4 \times 10^{-4} \text{kg} \cdot \text{m}^2$ (40.46 oz · in²) use the rubber coupling]
fs: Maximum self-start frequency when not loaded

103H7823-0140
103H7823-0110

103H7823-0160
103H7823-0130

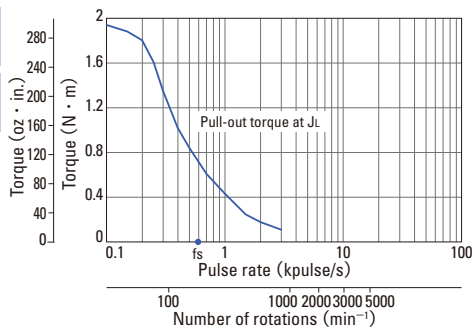

Constant current circuit
Source voltage : DC24V · Operating current : 1A/phase,
2-phase energization (full-step)
 $J_L=7.4 \times 10^{-4} \text{kg} \cdot \text{m}^2$ (40.46 oz · in²) use the rubber coupling]
fs: Maximum self-start frequency when not loaded

103H7823-0440
103H7823-0410

103H7823-0460
103H7823-0430

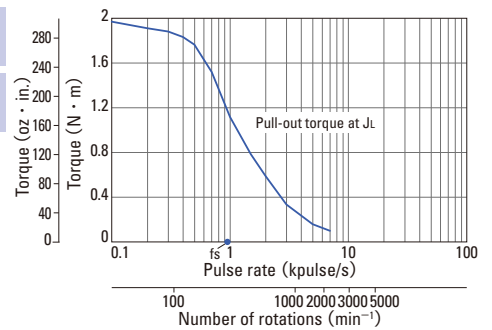

Constant current circuit
Source voltage : DC24V · Operating current : 2A/phase,
2-phase energization (full-step)
 $J_L=7.4 \times 10^{-4} \text{kg} \cdot \text{m}^2$ (40.46 oz · in²) use the rubber coupling]
fs: Maximum self-start frequency when not loaded

103H7823-0740
103H7823-0710

103H7823-0760
103H7823-0730

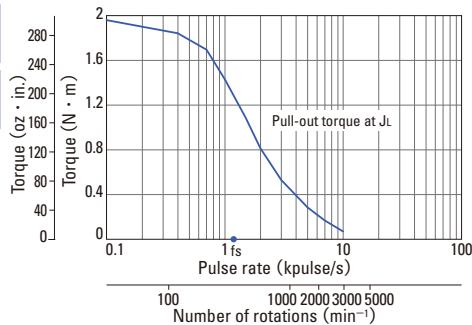

Constant current circuit
Source voltage : DC24V · Operating current : 3A/phase,
2-phase energization (full-step)
 $J_L=7.4 \times 10^{-4} \text{kg} \cdot \text{m}^2$ (40.46 oz · in²) use the rubber coupling]
fs: Maximum self-start frequency when not loaded



60mm sq. (2.36inch sq.)

1.8° /step

Unipolar winding · Connector type ▶ P.44

Unipolar winding · Lead wire type Dimensions for attaching NEMA23 are interchangeable (47.14mm-pitch) ▶ P.44

Bipolar winding · Connector type

Bipolar winding · Lead wire type Dimensions for attaching NEMA23 are interchangeable (47.14mm-pitch)

Bipolar winding · Connector type

Model number		Holding torque at 2-phase energization	Rated current	Wiring resistance	Winding inductance	Rotor inertia	Mass (Weight)
Single shaft	Double shafts	[N · m (oz · in) MIN.]	A/phase	Ω /phase	mH/phase	[×10 ⁻⁴ kg · m ² (oz · in ²)]	[kg (lbs)]
103H7821-5740	103H7821-5710	0.88 (124.6)	2	1.27	3.3	0.275 (1.50)	0.6 (1.32)
103H7821-1740	103H7821-1710	0.88 (124.6)	4	0.35	0.8	0.275 (1.50)	0.6 (1.32)
103H7822-5740	103H7822-5710	1.37 (194.0)	2	1.55	5.5	0.4 (2.19)	0.77 (1.70)
103H7822-1740	103H7822-1710	1.37 (194.0)	4	0.43	1.38	0.4 (2.19)	0.77 (1.70)
103H7823-5740	103H7823-5710	2.7 (382.3)	2	2.4	9.5	0.84 (4.59)	1.34 (2.95)
103H7823-1740	103H7823-1710	2.7 (382.3)	4	0.65	2.4	0.84 (4.59)	1.34 (2.95)

Motor cable : Model No. 4837961-1

Bipolar winding · Lead wire type Dimensions for attaching NEMA23 are interchangeable (47.14mm-pitch)

Model number		Holding torque at 2-phase energization	Rated current	Wiring resistance	Winding inductance	Rotor inertia	Mass (Weight)
Single shaft	Double shafts	[N · m (oz · in) MIN.]	A/phase	Ω /phase	mH/phase	[×10 ⁻⁴ kg · m ² (oz · in ²)]	[kg (lbs)]
103H7821-5760	103H7821-5730	0.88 (124.6)	2	1.27	3.3	0.275 (1.50)	0.6 (1.32)
103H7821-1760	103H7821-1730	0.88 (124.6)	4	0.35	0.8	0.275 (1.50)	0.6 (1.32)
103H7822-5760	103H7822-5730	1.37 (194.0)	2	1.55	5.5	0.4 (2.19)	0.77 (1.70)
103H7822-1760	103H7822-1730	1.37 (194.0)	4	0.43	1.38	0.4 (2.19)	0.77 (1.70)
103H7823-5760	103H7823-5730	2.7 (382.3)	2	2.4	9.5	0.84 (4.59)	1.34 (2.95)
103H7823-1760	103H7823-1730	2.7 (382.3)	4	0.65	2.4	0.84 (4.59)	1.34 (2.95)

Characteristics diagram

103H7821-5740
103H7821-5710

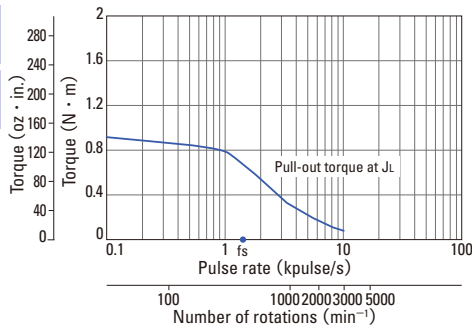

103H7821-5760
103H7821-5730

Constant current circuit
Source voltage : DC24V · Operating current : 2A/phase,
2-phase energization (full-step)
J_L=[2.6 × 10⁻⁴kg · m² (14.22 oz · in²) use the rubber coupling]
fs: Maximum self-start frequency when not loaded

103H7821-1740
103H7821-1710

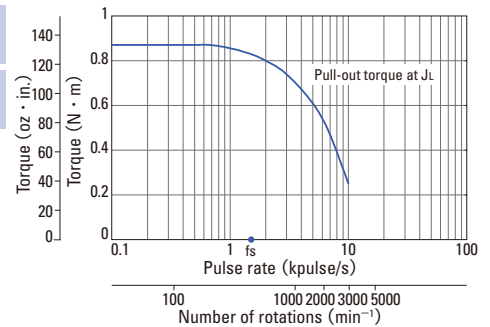

103H7821-1760
103H7821-1730

Constant current circuit
Source voltage : AC100V · operating current : 4A/phase,
2-phase energization (full-step)
J_L=[2.6 × 10⁻⁴kg · m² (14.22 oz · in²) use the rubber coupling]
fs: Maximum self-start frequency when not loaded

103H7822-5740
103H7822-5710

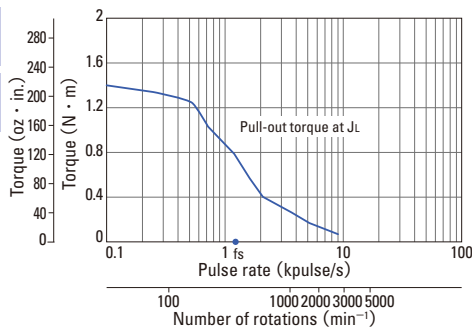

103H7822-5760
103H7822-5730

Constant current circuit
Source voltage : DC24V · Operating current : 2A/phase,
2-phase energization (full-step)
J_L=[2.6 × 10⁻⁴kg · m² (14.22 oz · in²) use the rubber coupling]
fs: Maximum self-start frequency when not loaded

103H7822-1740
103H7822-1710

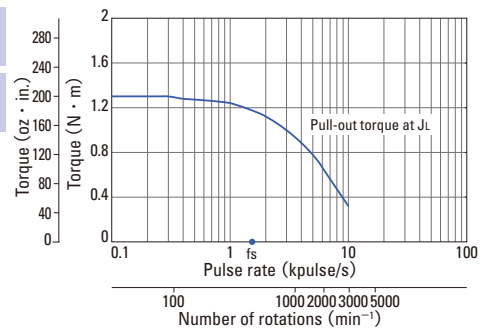

103H7822-1760
103H7822-1730

Constant current circuit
Source voltage : AC100V · operating current : 4A/phase,
2-phase energization (full-step)
J_L=[2.6 × 10⁻⁴kg · m² (14.22 oz · in²) use the rubber coupling]
fs: Maximum self-start frequency when not loaded

Characteristics diagram

103H7823-5740
103H7823-5710

103H7823-5760
103H7823-5730

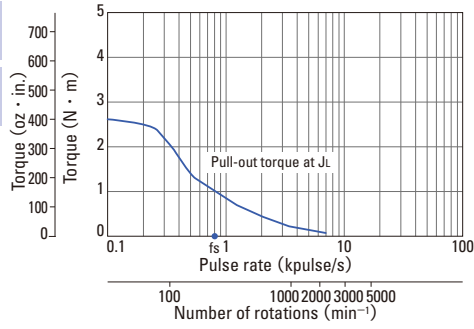

Constant current circuit
Source voltage : DC24V · Operating current : 2A/phase,
2-phase energization (full-step)
[$J_L=7.4 \times 10^{-4} \text{kg} \cdot \text{m}^2$ (40.46 oz · in²) use the rubber coupling]
fs: Maximum self-start frequency when not loaded

103H7823-1740
103H7823-1710

103H7823-1760
103H7823-1730

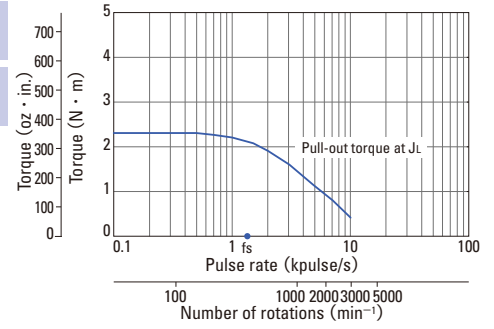

Constant current circuit
Source voltage : AC100V · operating current : 4A/phase,
2-phase energization (full-step)
[$J_L=7.4 \times 10^{-4} \text{kg} \cdot \text{m}^2$ (40.46 oz · in²) use the rubber coupling]
fs: Maximum self-start frequency when not loaded



86mm sq. (3.39inch sq.)

1.8° /step

- Unipolar winding · Lead wire type
- Unipolar winding · Lead wire type CE · UL model
- Bipolar winding · Lead wire type ▶ P.50
- Bipolar winding · Lead wire type CE · UL model ▶ P.50
- Bipolar winding · Terminal block type CE · UL model ▶ P.50

Unipolar winding · Lead wire type

Model number		Holding torque at 2-phase energization	Rated current	Wiring resistance	Winding inductance	Rotor inertia	Mass (Weight)
Single shaft	Double shafts	[N · m (oz · in) MIN.]	A/phase	Ω /phase	mH/phase	[×10 ⁻⁴ kg · m ² (oz · in ²)]	[kg (lbs)]
SH2861-0441	SH2861-0411	2.5 (354)	2	2.3	8.0	1.48 (8.09)	1.75 (3.92)
SH2861-0941	SH2861-0911	2.5 (354)	4	0.6	2.0	1.48 (8.09)	1.75 (3.92)
SH2862-0441	SH2862-0411	4.7 (665.6)	2	3.2	13.0	3.0 (16.4)	2.9 (6.5)
SH2862-0941	SH2862-0911	4.7 (665.6)	4	0.85	3.4	3.0 (16.4)	2.9 (6.5)
SH2863-0441	SH2863-0411	6.7 (948.8)	2	4.0	17.0	4.5 (24.6)	4.0 (8.96)
SH2863-0941	SH2863-0911	6.7 (948.8)	4	0.9	4.2	4.5 (24.6)	4.0 (8.96)

Unipolar winding · Lead wire type CE · UL model

Model number		Holding torque at 2-phase energization	Rated current	Wiring resistance	Winding inductance	Rotor inertia	Mass (Weight)
Single shaft	Double shafts	[N · m (oz · in) MIN.]	A/phase	Ω /phase	mH/phase	[×10 ⁻⁴ kg · m ² (oz · in ²)]	[kg (lbs)]
SM2861-0451	SM2861-0421	2.5 (354)	2	2.3	8.0	1.48 (8.09)	1.75 (3.92)
SM2861-0951	SM2861-0921	2.5 (354)	4	0.6	2.0	1.48 (8.09)	1.75 (3.92)
SM2862-0451	SM2862-0421	4.7 (665.6)	2	3.2	13.0	3.0 (16.4)	2.9 (6.5)
SM2862-0951	SM2862-0921	4.7 (665.6)	4	0.85	3.4	3.0 (16.4)	2.9 (6.5)
SM2863-0451	SM2863-0421	6.7 (948.8)	2	4.0	17.0	4.5 (24.6)	4.0 (8.96)
SM2863-0951	SM2863-0921	6.7 (948.8)	4	0.9	4.2	4.5 (24.6)	4.0 (8.96)

Characteristics diagram

SH2861-0441
SH2861-0411

SM2861-0451
SM2861-0421

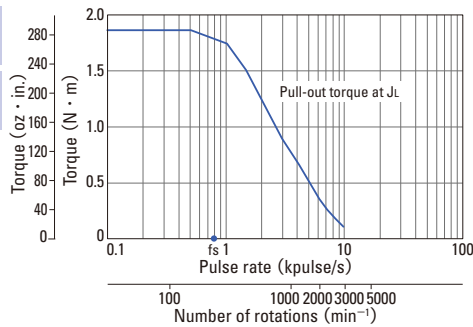

Constant current circuit
Source voltage : AC100V · operating current : 2A/phase,
2-phase energization (full-step)
[J_L=7.4 × 10⁻⁴kg · m² (40.46 oz · in²) use the rubber coupling]
fs: Maximum self-start frequency when not loaded

SH2861-0941
SH2861-0911

SM2861-0951
SM2861-0921

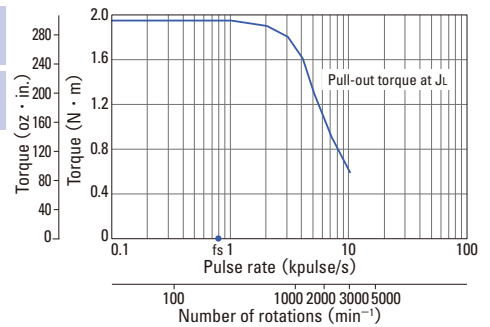

Constant current circuit
Source voltage : AC100V · operating current : 4A/phase,
2-phase energization (full-step)
[J_L=7.4 × 10⁻⁴kg · m² (40.46 oz · in²) use the rubber coupling]
fs: Maximum self-start frequency when not loaded

SH2862-0441
SH2862-0411

SM2862-0451
SM2862-0421

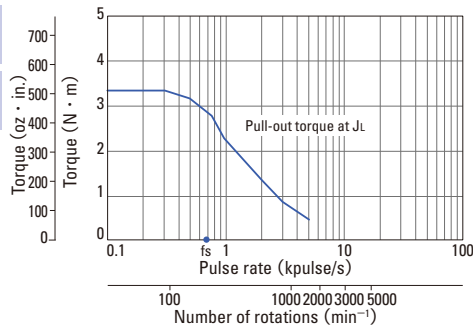

Constant current circuit
Source voltage : AC100V · operating current : 2A/phase,
2-phase energization (full-step)
J_L=[15.3 × 10⁻⁴kg · m² (83.65 oz · in²) use the rubber coupling]
fs: Maximum self-start frequency when not loaded

SH2862-0941
SH2862-0911

SM2862-0951
SM2862-0921

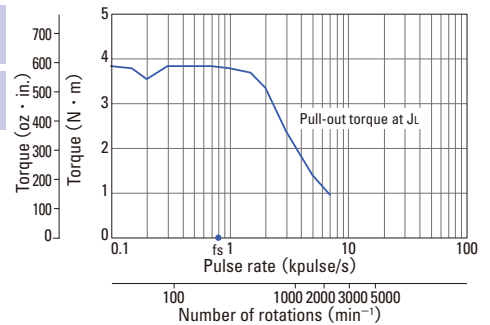

Constant current circuit
Source voltage : AC100V · operating current : 4A/phase,
2-phase energization (full-step)
J_L=[15.3 × 10⁻⁴kg · m² (83.65 oz · in²) use the rubber coupling]
fs: Maximum self-start frequency when not loaded

Characteristics diagram

SH2863-0441
SH2863-0411

SM2863-0451
SM2863-0421

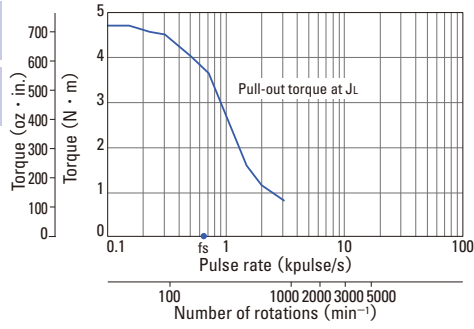

Constant current circuit
Source voltage : AC100V · operating current : 2A/phase,
2-phase energization (full-step)
 $J_L = [15.3 \times 10^{-4} \text{kg} \cdot \text{m}^2 (83.65 \text{oz} \cdot \text{in}^2)]$ use the rubber coupling]
fs: Maximum self-start frequency when not loaded

SH2863-0941
SH2863-0911

SM2863-0951
SM2863-0921

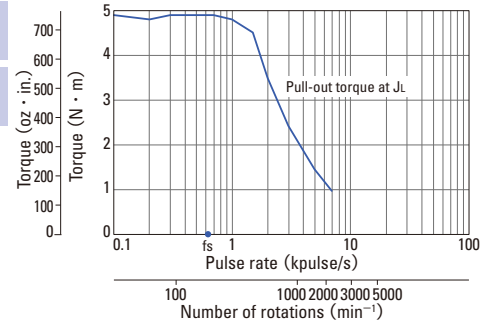

Constant current circuit
Source voltage : AC100V · operating current : 4A/phase,
2-phase energization (full-step)
 $J_L = [15.3 \times 10^{-4} \text{kg} \cdot \text{m}^2 (83.65 \text{oz} \cdot \text{in}^2)]$ use the rubber coupling]
fs: Maximum self-start frequency when not loaded



86mm sq. (3.39inch sq.)

1.8° /step

Unipolar winding · Lead wire type ▶ P.48

Unipolar winding · Lead wire type CE · UL model ▶ P.48

Bipolar winding · Lead wire type

Bipolar winding · Lead wire type CE · UL model

Bipolar winding · Terminal block type CE · UL model

Bipolar winding · Lead wire type

Model number		Holding torque at 2-phase energization [N · m (oz · in) MIN.]	Rated current A/phase	Wiring resistance Ω /phase	Winding inductance mH/phase	Rotor inertia [×10 ⁻⁴ kg · m ² (oz · in ²)]	Mass (Weight) [kg (lbs)]
Single shaft	Double shafts						
SH2861-5041	SH2861-5011	3.3 (467.3)	2	2.2	15	1.48 (8.09)	1.75 (3.92)
SH2861-5141	SH2861-5111	3.3 (467.3)	4	0.56	3.7	1.48 (8.09)	1.75 (3.92)
SH2861-5241	SH2861-5211	3.3 (467.3)	6	0.29	1.7	1.48 (8.09)	1.75 (3.92)
SH2862-5041	SH2862-5011	6.4 (906.3)	2	3.2	25	3.0 (16.4)	2.9 (6.5)
SH2862-5141	SH2862-5111	6.4 (906.3)	4	0.83	6.4	3.0 (16.4)	2.9 (6.5)
SH2862-5241	SH2862-5211	6.4 (906.3)	6	0.36	2.8	3.0 (16.4)	2.9 (6.5)
SH2863-5041	SH2863-5011	9 (1274.4)	2	4.0	32	4.5 (24.6)	4.0 (8.96)
SH2863-5141	SH2863-5111	9 (1274.4)	4	1.0	7.9	4.5 (24.6)	4.0 (8.96)
SH2863-5241	SH2863-5211	9 (1274.4)	6	0.46	3.8	4.5 (24.6)	4.0 (8.96)

Bipolar winding · Lead wire type CE · UL model

Model number		Holding torque at 2-phase energization [N · m (oz · in) MIN.]	Rated current A/phase	Wiring resistance Ω /phase	Winding inductance mH/phase	Rotor inertia [×10 ⁻⁴ kg · m ² (oz · in ²)]	Mass (Weight) [kg (lbs)]
Single shaft	Double shafts						
SM2861-5051	SM2861-5021	3.3 (467.3)	2	2.2	15	1.48 (8.09)	1.75 (3.92)
SM2861-5151	SM2861-5121	3.3 (467.3)	4	0.56	3.7	1.48 (8.09)	1.75 (3.92)
SM2861-5251	SM2861-5221	3.3 (467.3)	6	0.29	1.7	1.48 (8.09)	1.75 (3.92)
SM2862-5051	SM2862-5021	6.4 (906.3)	2	3.2	25	3.0 (16.4)	2.9 (6.5)
SM2862-5151	SM2862-5121	6.4 (906.3)	4	0.83	6.4	3.0 (16.4)	2.9 (6.5)
SM2862-5251	SM2862-5221	6.4 (906.3)	6	0.36	2.8	3.0 (16.4)	2.9 (6.5)
SM2863-5051	SM2863-5021	9 (1274.4)	2	4.0	32	4.5 (24.6)	4.0 (8.96)
SM2863-5151	SM2863-5121	9 (1274.4)	4	1.0	7.9	4.5 (24.6)	4.0 (8.96)
SM2863-5251	SM2863-5221	9 (1274.4)	6	0.46	3.8	4.5 (24.6)	4.0 (8.96)

Bipolar winding · Terminal block type CE · UL model

Model number		Holding torque at 2-phase energization [N · m (oz · in) MIN.]	Rated current A/phase	Wiring resistance Ω /phase	Winding inductance mH/phase	Rotor inertia [×10 ⁻⁴ kg · m ² (oz · in ²)]	Mass (Weight) [kg (lbs)]
Single shaft	Double shafts						
SM2861-5066		3.3 (467.3)	2	2.03	15	1.48 (8.09)	1.9 (4.19)
SM2861-5166		3.3 (467.3)	4	0.52	3.7	1.48 (8.09)	1.9 (4.19)
SM2861-5266		3.3 (467.3)	6	0.27	1.7	1.48 (8.09)	1.9 (4.19)
SM2862-5066		6.4 (906.3)	2	3.08	25	3.0 (16.4)	3.05 (6.72)
SM2862-5166		6.4 (906.3)	4	0.79	6.4	3.0 (16.4)	3.05 (6.72)
SM2862-5266		6.4 (906.3)	6	0.33	2.8	3.0 (16.4)	3.05 (6.72)
SM2863-5066		9 (1274.4)	2	3.83	32	4.5 (24.6)	4.15 (9.15)
SM2863-5166		9 (1274.4)	4	0.96	7.9	4.5 (24.6)	4.15 (9.15)
SM2863-5266		9 (1274.4)	6	0.48	3.8	4.5 (24.6)	4.15 (9.15)

Characteristics diagram

SH2861-5041
SH2861-5011

SM2861-5051
SM2861-5021

SM2861-5066

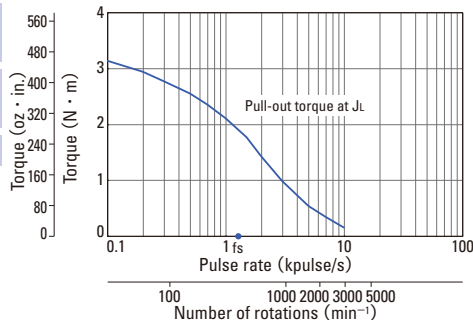

Constant current circuit
Source voltage : AC100V · operating current : 2A/phase,
2-phase energization (full-step)
[J₁=7.4 × 10⁻⁴kg · m² (40.46 oz · in²) use the rubber coupling]
fs: Maximum self-start frequency when not loaded

SH2861-5141
SH2861-5111

SM2861-5151
SM2861-5121

SM2861-5166

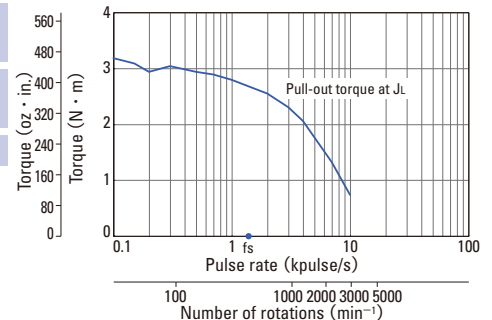

Constant current circuit
Source voltage : AC100V · operating current : 4A/phase,
2-phase energization (full-step)
[J₁=7.4 × 10⁻⁴kg · m² (40.46 oz · in²) use the rubber coupling]
fs: Maximum self-start frequency when not loaded

Characteristics diagram

SH2861-5241
SH2861-5211

SM2861-5251
SM2861-5221

SM2861-5266

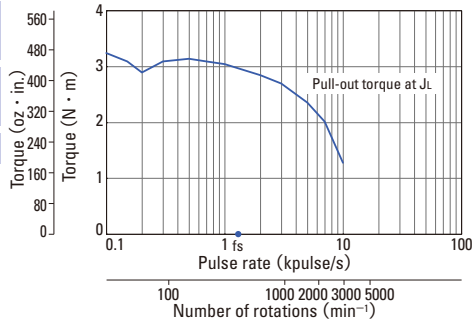

Constant current circuit
Source voltage : AC100V · operating current : 6A/phase,
2-phase energization (full-step)
 $J_t = [15.3 \times 10^{-4} \text{kg} \cdot \text{m}^2 (83.65 \text{oz} \cdot \text{in}^2)]$ use the rubber coupling]
 f_s : Maximum self-start frequency when not loaded

SH2862-5041
SH2862-5011

SM2862-5051
SM2862-5021

SM2862-5066

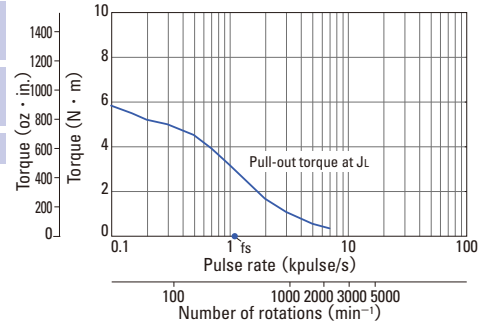

Constant current circuit
Source voltage : AC100V · operating current : 2A/phase,
2-phase energization (full-step)
 $J_t = [15.3 \times 10^{-4} \text{kg} \cdot \text{m}^2 (83.65 \text{oz} \cdot \text{in}^2)]$ use the rubber coupling]
 f_s : Maximum self-start frequency when not loaded

SH2862-5141
SH2862-5111

SM2862-5151
SM2862-5121

SM2862-5166

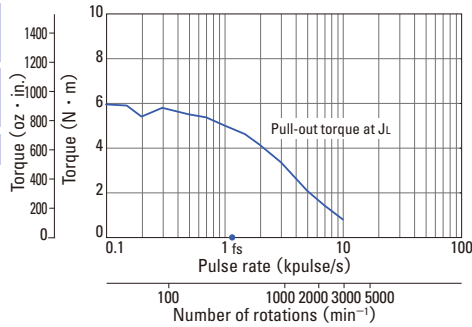

Constant current circuit
Source voltage : AC100V · operating current : 4A/phase,
2-phase energization (full-step)
 $J_t = [15.3 \times 10^{-4} \text{kg} \cdot \text{m}^2 (83.65 \text{oz} \cdot \text{in}^2)]$ use the rubber coupling]
 f_s : Maximum self-start frequency when not loaded

SH2862-5241
SH2862-5211

SM2862-5251
SM2862-5221

SM2862-5266

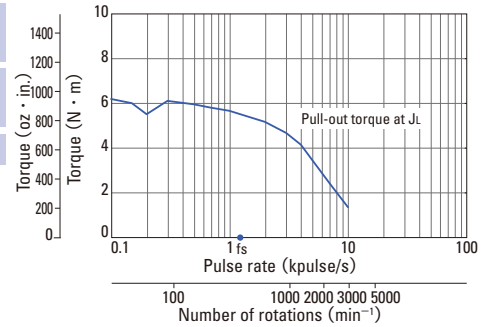

Constant current circuit
Source voltage : AC100V · operating current : 6A/phase,
2-phase energization (full-step)
 $J_t = [15.3 \times 10^{-4} \text{kg} \cdot \text{m}^2 (83.65 \text{oz} \cdot \text{in}^2)]$ use the rubber coupling]
 f_s : Maximum self-start frequency when not loaded

SH2863-5041
SH2863-5011

SM2863-5051
SM2863-5021

SM2863-5066

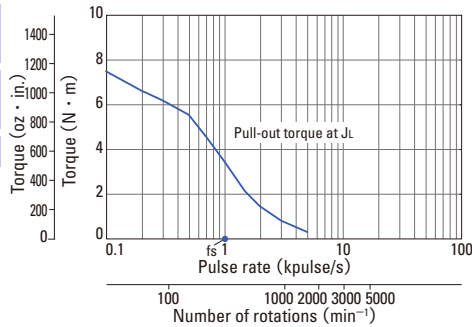

Constant current circuit
Source voltage : AC100V · operating current : 2A/phase,
2-phase energization (full-step)
 $J_t = [43 \times 10^{-4} \text{kg} \cdot \text{m}^2 (235.10 \text{oz} \cdot \text{in}^2)]$ use the rubber coupling]
 f_s : Maximum self-start frequency when not loaded

SH2863-5141
SH2863-5111

SM2863-5151
SM2863-5121

SM2863-5166

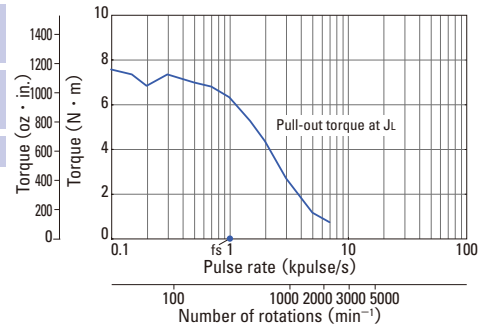

Constant current circuit
Source voltage : AC100V · operating current : 4A/phase,
2-phase energization (full-step)
 $J_t = [43 \times 10^{-4} \text{kg} \cdot \text{m}^2 (235.10 \text{oz} \cdot \text{in}^2)]$ use the rubber coupling]
 f_s : Maximum self-start frequency when not loaded

SH2863-5241
SH2863-5211

SM2863-5251
SM2863-5221

SM2863-5266

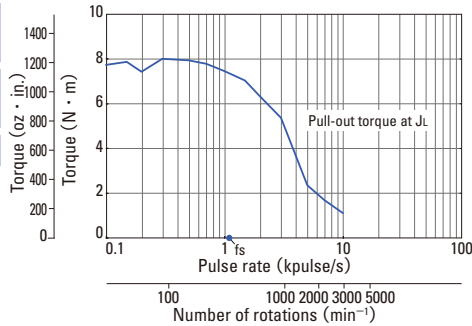

Constant current circuit
Source voltage : AC100V · operating current : 6A/phase,
2-phase energization (full-step)
 $J_t = [43 \times 10^{-4} \text{kg} \cdot \text{m}^2 (235.10 \text{oz} \cdot \text{in}^2)]$ use the rubber coupling]
 f_s : Maximum self-start frequency when not loaded



φ 106mm (φ 4.17inch)

1.8° /step

Unipolar winding · Lead wire type
Bipolar winding · Lead wire type

Unipolar winding · Lead wire type

Model number		Holding torque at 2-phase energization	Rated current	Wiring resistance	Winding inductance	Rotor inertia	Mass (Weight)
Single shaft	Double shafts	[N · m (oz · in) MIN.]	A/phase	Ω /phase	mH/phase	[×10 ⁻⁴ kg · m ² (oz · in ²)]	[kg (lbs)]
103H89222-0941	103H89222-0911	10.8 (1529.4)	4	0.98	6.3	14.6 (79.83)	7.5 (16.53)
103H89223-0941	103H89223-0911	15.5 (2194.9)	4	1.4	9.7	22 (120.28)	10.5 (23.15)

Bipolar winding · Lead wire type

Model number		Holding torque at 2-phase energization	Rated current	Wiring resistance	Winding inductance	Rotor inertia	Mass (Weight)
Single shaft	Double shafts	[N · m (oz · in) MIN.]	A/phase	Ω /phase	mH/phase	[×10 ⁻⁴ kg · m ² (oz · in ²)]	[kg (lbs)]
103H89222-5241	103H89222-5211	13.2 (1869.2)	6	0.45	5.4	14.6 (79.83)	7.5 (16.53)
103H89223-5241	103H89223-5211	19 (2690.5)	6	0.63	8	22 (120.28)	10.5 (23.15)

Characteristics diagram

103H89222-0941
103H89222-0911

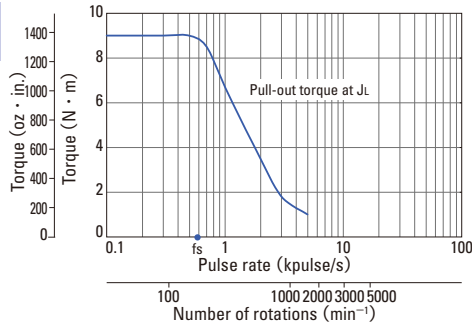

Constant current circuit
Source voltage : AC100V · operating current : 4A/phase,
2-phase energization (full-step)
 $J_L = [43 \times 10^{-4} \text{kg} \cdot \text{m}^2 (235.10 \text{oz} \cdot \text{in}^2)]$ use the rubber coupling)
fs: Maximum self-start frequency when not loaded

103H89223-0941
103H89223-0911

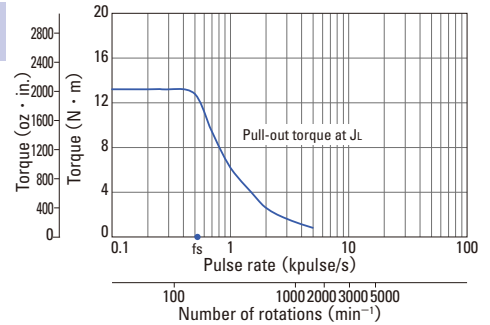

Constant current circuit
Source voltage : AC100V · operating current : 4A/phase,
2-phase energization (full-step)
 $J_L = [43 \times 10^{-4} \text{kg} \cdot \text{m}^2 (235.10 \text{oz} \cdot \text{in}^2)]$ use the rubber coupling)
fs: Maximum self-start frequency when not loaded

103H89222-5241
103H89222-5211

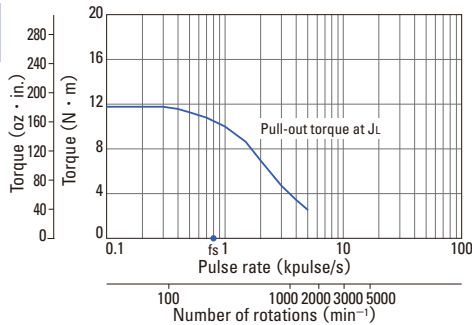

Constant current circuit
Source voltage : AC100V · operating current : 6A/phase,
2-phase energization (full-step)
 $J_L = [43 \times 10^{-4} \text{kg} \cdot \text{m}^2 (235.10 \text{oz} \cdot \text{in}^2)]$ use the rubber coupling)
fs: Maximum self-start frequency when not loaded

103H89223-5241
103H89223-5211

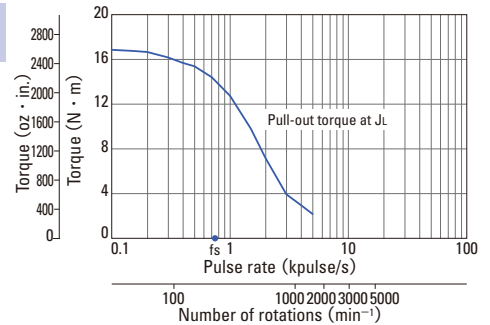

Constant current circuit
Source voltage : AC100V · operating current : 6A/phase,
2-phase energization (full-step)
 $J_L = [43 \times 10^{-4} \text{kg} \cdot \text{m}^2 (235.10 \text{oz} \cdot \text{in}^2)]$ use the rubber coupling)
fs: Maximum self-start frequency when not loaded

Allowable radial / thrust load

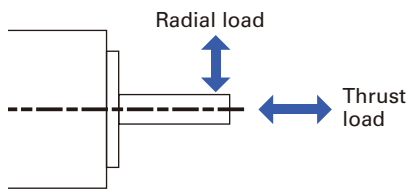

Frange size	Model number	Distance from end of shaft : mm (inch)				Thrust load N (lbs)
		0	5	10	15	
14mm sq. (0.55inch sq.)	SH2141	10 (2.25)	11 (2.47)	13 (2.92)	-	0.7 (0.16)
28mm sq. (1.10inch sq.)	SH228 □	42 (9)	48 (10)	56 (12)	66 (14)	3 (0.67)
35mm sq. (1.38inch sq.)	SH353 □	40 (8)	50 (11)	67 (15)	98 (22)	10 (2.25)
42mm sq. (1.65inch sq.)	103H52 □□ SH142 □	22 (4)	26 (5)	33 (7)	46 (10)	10 (2.25)
50mm sq. (1.97inch sq.)	103H670 □	71 (15)	87 (19)	115 (25)	167 (37)	15 (3.37)
56mm sq. (2.20inch sq.)	103H712 □	52 (11)	65 (14)	85 (19)	123 (27)	15 (3.37)
	103H7128	85 (19)	105 (23)	138 (31)	200 (44)	15 (3.37)
60mm sq. (2.36inch sq.)	103H782 □	70 (15)	87 (19)	114 (25)	165 (37)	20 (4.50)
	SH160 □					15 (3.37)
86mm sq. (3.39inch sq.)	SM286 □	167 (37)	193 (43)	229 (51)	280 (62)	60 (13.488)
	SH286 □					
φ106mm (φ4.17inch)	103H8922 □	321 (72)	356 (79)	401 (90)	457 (101)	100 (22.48)

Internal Wiring and Rotation Direction

Unipolar winding

103H52 □□ Connector type

Internal wire connection

() connector pin number

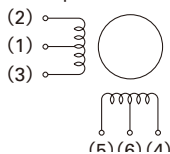

103H782 □□ Connector type

Internal wire connection

() connector pin number

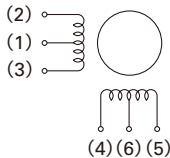

Lead wire type

Internal wire connection

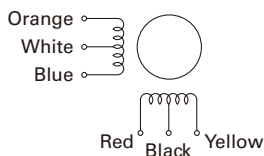

Direction of motor rotate

The output shaft shall rotate clockwise as seen from the shaft side, when excited by DC in the following order.

Exciting order	Connector pin number				
	(1.6)	(5)	(3)	(4)	(2)
1	+	-	-	-	-
2	+	-	-	-	-
3	+	-	-	-	-
4	+	-	-	-	-

Direction of motor rotate

The output shaft shall rotate clockwise as seen from the shaft side, when excited by DC in the following order.

Exciting order	Connector pin number				
	(1.6)	(4)	(3)	(5)	(2)
1	+	-	-	-	-
2	+	-	-	-	-
3	+	-	-	-	-
4	+	-	-	-	-

Direction of motor rotate

The output shaft shall rotate clockwise as seen from the shaft side, when excited by DC in the following order.

Exciting order	リード線色				
	White & black	Red	Blue	Yellow	Orange
1	+	-	-	-	-
2	+	-	-	-	-
3	+	-	-	-	-
4	+	-	-	-	-

Bipolar winding

Connector type

Internal wire connection

() connector pin number · terminal block number

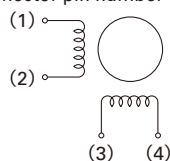

Lead wire type

Internal wire connection

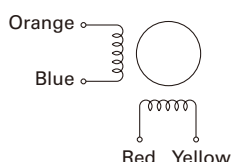

Direction of motor rotate

The output shaft shall rotate clockwise as seen from the shaft side, when excited by DC in the following order.

Exciting order	Connector pin number · terminal block number			
	(3)	(2)	(4)	(1)
1	-	-	+	+
2	+	-	-	+
3	+	+	-	-
4	-	+	+	-

Direction of motor rotate

The output shaft shall rotate clockwise as seen from the shaft side, when excited by DC in the following order.

Exciting order	Lead wire color			
	Red	Blue	Yellow	Orange
1	-	-	+	+
2	+	-	-	+
3	+	+	-	-
4	-	+	+	-

General Specifications

Motor model number	SH2141	SH228 <input type="checkbox"/>	SH353 <input type="checkbox"/>	SS242 <input type="checkbox"/>	SH142 <input type="checkbox"/>	103H52 <input type="checkbox"/>	SS250 <input type="checkbox"/>	103H67 <input type="checkbox"/>	103H712 <input type="checkbox"/>
Type	-								
Operating ambient temperature	- 10°C to + 50°C								
Conversation temperature	- 20°C to + 65°C								
Operating ambient humidity	95%MAX. : 40°C MAX., 57%MAX. : 50°C MAX., 35%MAX. : 60°C MAX. (no condensation)								
Conversation humidity									
Operation altitude	1000m (3280 feet) MAX above sea level								
Vibration resistance	Vibration frequency 10 to 500 Hz, total amplitude 1.52 mm (10 to 70 Hz), vibration acceleration 147m/s ² (70 to 500 Hz), sweep time 15 min/cycle, 12 sweeps in each X, Y and Z direction.								
Impact resistance	490m/s ² of acceleration for 11 ms with half-sine wave applying three times for X, Y, and Z axes each, 18 times in total.								
Insulation class	Class B (+130°C)								
Withstand voltage	At normal temperature and humidity, no failure with 500 V AC @50/60 Hz applied for oneminute between motor winding and frame.							At normal temperature and humidity, no failure with 1000 V AC @50/60 Hz applied for oneminute between motor winding and frame.	
Insulation resistance	At normal temperature and humidity, not less than 100M Ω between winding and frame by DC500V megger.								
Protection grade	IP40								
Winding temperature rise	80K MAX. (Based on Sanyo Denki standard)								
Static angle error	± 0.09°			± 0.054°		± 0.09°			
Axial play ^(Note 1)	0.075 mm (0.003 inch) MAX. (load: 4.4N (1 lbs))						0.075mm (0.003inch) max. (load: 9N (2.02lbs))		
Radial play ^(Note 2)	0.025 mm (0.001 inch) MAX. (load: 4.4N (1 lbs))								
Shaft runout	0.025 mm (0.001 inch)								
Concentricity of mounting pilot relative to shaft	φ 0.05mm (φ 0.002inch)						φ 0.075mm (φ 0.003inch)		
Squareness of mounting surface relative to shaft	0.1mm (0.004inch)						0.075mm (0.003inch)		

Motor model number	SH160 <input type="checkbox"/>	103H78 <input type="checkbox"/>	SH286 <input type="checkbox"/>	103H8922 <input type="checkbox"/>	SM286 <input type="checkbox"/>
Type	-				S1 (continuous operation)
Operating ambient temperature	- 10°C to + 50°C				- 10°C ~ + 40°C
Conversation temperature	- 20°C to + 65°C				- 20°C ~ + 60°C
Operating ambient humidity	95%MAX. : 40°C MAX., 57%MAX. : 50°C MAX., 35%MAX. : 60°C MAX. (no condensation)				
Conversation humidity					
Operation altitude	1000m (3280 feet) MAX above sea level				
Vibration resistance	Vibration frequency 10 to 500 Hz, total amplitude 1.52 mm (10 to 70 Hz), vibration acceleration 147m/s ² (70 to 500 Hz), sweep time 15 min/cycle, 12 sweeps in each X, Y and Z direction.				
Impact resistance	490m/s ² of acceleration for 11 ms with half-sine wave applying three times for X, Y, and Z axes each, 18 times in total.				
Insulation class	Class B (+130°C)				Class F (+155°C)
Withstand voltage	At normal temperature and humidity, no failure with 1000 V AC @50/60 Hz applied for one minute between motor winding and frame.			At normal temperature and humidity, no failure with 1500 V AC @50/60 Hz applied for oneminute between motor winding and frame.	
Insulation resistance	At normal temperature and humidity, not less than 100M Ω between winding and frame by DC500V megger.				
Protection grade	IP40				IP43
Winding temperature rise	80K MAX. (Based on Sanyo Denki standard)				
Static angle error	± 0.054°		± 0.09°		
Axial play ^(Note 1)	0.075mm (0.003inch) max. (load: 9N (2.02lbs))				
Radial play ^(Note 2)	0.025 mm (0.001 inch) MAX. (load: 4.4N (1 lbs))				
Shaft runout	0.025 mm (0.001 inch)				
Concentricity of mounting pilot relative to shaft	φ 0.075mm (φ 0.003inch)				
Squareness of mounting surface relative to shaft	0.1mm (0.004inch)	0.075mm (0.003inch)	0.15mm (0.006inch)	0.075mm (0.003inch)	0.15mm (0.006inch)

(Note 1) Axial play: Shaft displacement under axial load.

(Note 2) Radial play: Shaft displacement under radial load applied 1/3rd of the length from the end of the shaft.

Safety standards

Model Number : SM286 CE • UL marked models

CE	Standard category		Standard part
	Low-voltage directives		EN60034-1, EN60034-5
UL	Acquired standards	Standard part	File No.
	UL	UL1004-1	E179832
	UL for Canada		

Stepping motors with integrated drivers

Dimensions ▶ P.70



Features

1. Driver and motor are now integrated into a single unit.
A driver incorporating a motion control function needed for driving a motor and a 2-phase stepping motor were integrated into a single unit for enabling a more compact installation space and less wiring.
2. Three types of operation modes can be selected to match the specific application.
 - (1) Pulse train interface mode:
Control by command pulses
 - (2) Parallel interface mode:
Program control by general-purpose I/O(Parallel)
 - (3) Serial interface mode:
Compliant with RS-485, half-duplex asynchronous communication

System configuration diagram

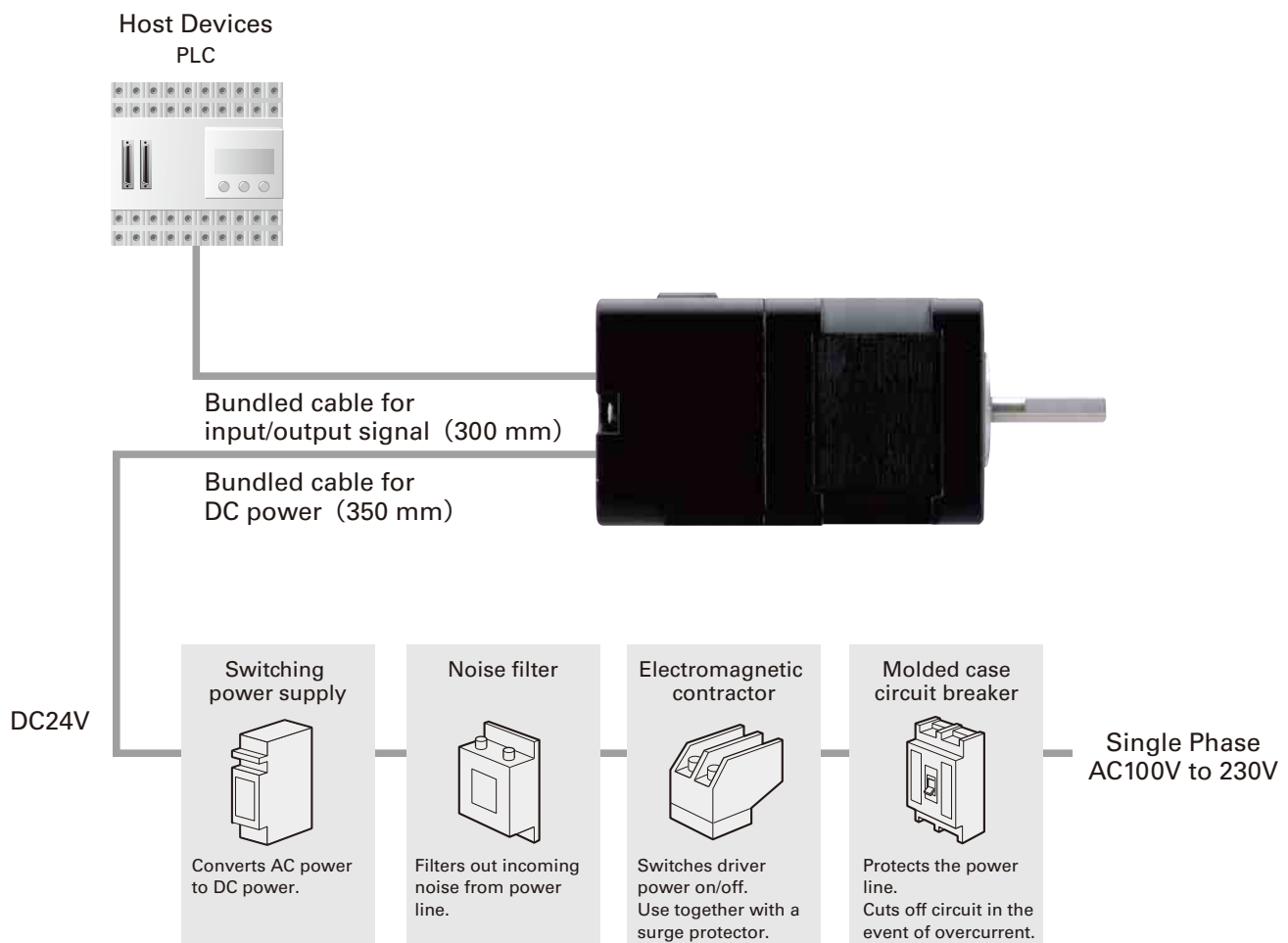

Specifications

Model number		DB21M142S-01	DB22M162S-01	
Basic specifications	Motor size	42mm sq. (1.65in sq.)	60mm sq. (2.36in sq.)	
	Input source ^(Note1)	DC24V ±10%		
	Source current (A)	2 MAX.	3 MAX.	
	Environment	Protection class	Class I	
		Operation environment	Installation category (over-voltage category) : I , pollution degree : 2	
		Operating ambient temperature ^(Note2)	0 to + 40°C	
		Conservation temperature	- 20 to + 60°C	
		Operating ambient humidity	35 to 85%RH (no condensation)	
		Conservation humidity	10 to 90%RH (no condensation)	
		Operation altitude	1000 m (3280 feet) MAX. above sea level	
		Vibration resistance	Tested under the following conditions ; 100m/s ² , frequency range 10 to 2000Hz, direction along X, Y and Z axes, for 2 hours each	
		Impact resistance	Not influenced at NDS-C-0110 standard section 3.2.2 division "C".	
	Withstand voltage	Not influenced when 500V AC is applied between power input terminal and cabinet for one minute.		
Insulation resistance	10M Ω MIN. when measured with 500V DC megohmmeter between input terminal and cabinet.			
Mass (Weight)	0.5kg (1.10lbs)	0.87kg (1.92lbs)		
Function	Protection function	Against driver overheat		
	LED indicator	Alarm monitor		
I/O signals	Command pulse input signal ^(Note3)	Photo coupler input method, input resistance 220 Ω	Input signal voltage : "H" = 4.0 to 5.5V, "L" = 0 to 0.5V	
	Power down input signal (PD)	Photo coupler input method, input resistance 470 Ω	Input signal voltage : "H" = 4.0 to 5.5V, "L" = 0 to 0.5V	
	Step angle setting selection input (EXT)	Photo coupler input method, input resistance 470 Ω	Input signal voltage : "H" = 4.0 to 5.5V, "L" = 0 to 0.5V	
	FULL/HALF setting selection input (F/H)	Photo coupler input method, input resistance 470 Ω	Input signal voltage : "H" = 4.0 to 5.5V, "L" = 0 to 0.5V	
	EMG input signal	Photo coupler input method, input resistance 470 Ω	Input signal voltage : "H" = 4.0 to 5.5V, "L" = 0 to 0.5V	
	BUSY output signal	Open collector output by photo coupler	Output signal standard : Vceo = 30V MAX., Ic = 20mA MAX.	
	Phase origin monitor output signal (MON)	Open collector output by photo coupler	Output signal standard : Vceo = 30V MAX., Ic = 20mA MAX.	
Alarm output signal (AL)	Open collector output by photo coupler	Output signal standard : Vceo = 30V MAX., Ic = 20mA MAX.		

(Note1) Note that the power voltage must not exceed 24VDC + 10% (26.4VDC).

(Note2) If the driver is placed in a box, the temperature inside the box must not exceed this specified range.

(Note3) The maximum input frequency is 250k pulse/s.

Safety standards

CE (TÜV)	Directives	Category	Name	Standard part					
	EMC directives	Low-voltage directives	-	-	DB21M142S-01	DB22M162S-01			
EN60034-1					EN60034-1				
EN60034-5					EN60034-5				
EN61010-1					EN61010-1				
Emission		-	-	Terminal disturbance voltage	EN55011-A	EN61000-6-4			
				Electromagnetic radiation disturbance	EN55011-A	EN61000-6-4			
				Immunity	-	-	ESD (Electrostatic discharge)	EN61000-4-2	EN61000-4-2
							RS (Radio-frequency amplitude modulated electromagnetic field)	EN61000-4-3	EN61000-4-3
							Fast transients	EN61000-4-4	EN61000-4-4
							Surges	EN61000-4-6	EN61000-4-6
UL	Acquired standards	Standard part	Standard part						
	UL	UL508C	E179775						
	UL for Canada								

• EMC characteristics may vary depending on the configuration of the users' control panel, which contains the driver or stepping motor, or the arrangement and wiring of other electrical devices.

Parts for EMC noise suppression like noise filters and toroidal type ferrite cores may be required depending on circumstances.

• Validation test of driver has been performed for low-voltage EMC directives at TÜV (TÜV product service) for self-declaration of CE marking.

Characteristics diagram

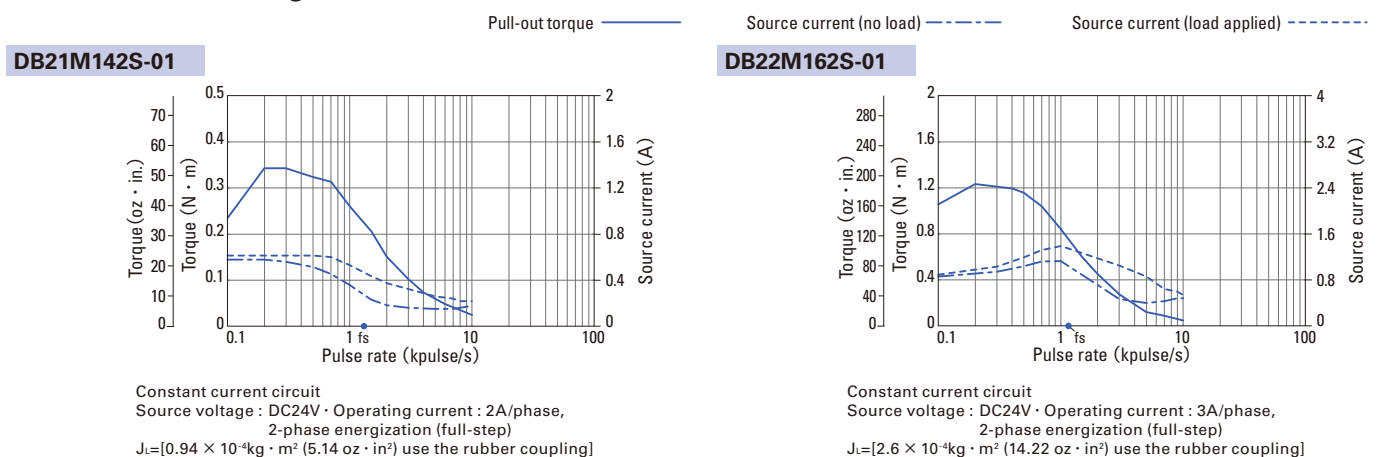

The data are measured under the drive condition of our company. Driving torque may vary according to actual machine precision.

Input circuit configuration (CW, CCW)

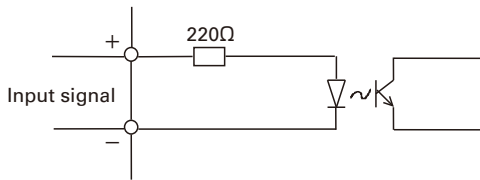

Input signal specifications

Negative logic

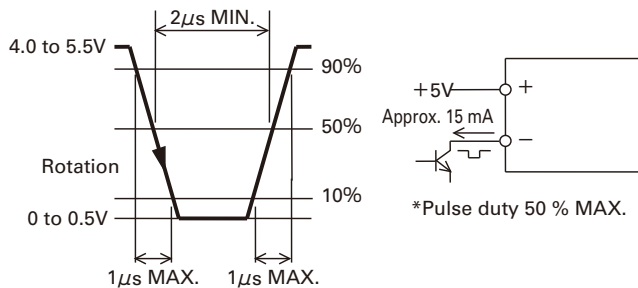

Positive logic

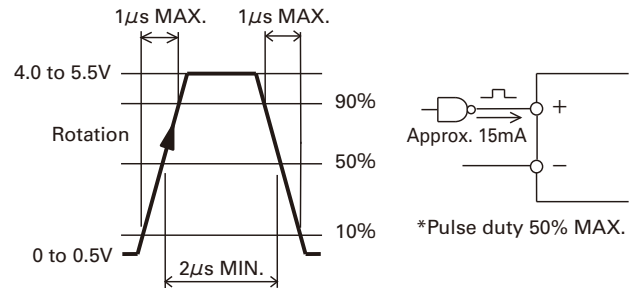

Timing of the command pulse

2-input mode (CW, CCW)

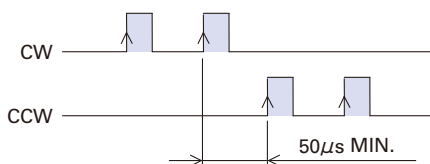

- The internal photo coupler turns ON within the and, at its falling edge to OFF, the internal circuit (motor) is activated.
- When applying the pulse to CW, turn OFF the CCW side internal photo coupler.
- When applying the pulse to CCW, turn OFF the CW side internal photo coupler.

Pulse and direction mode (CK, U/D)

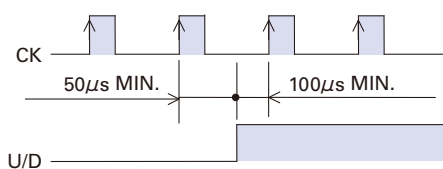

- The "H" level is input for and, at its rising edge to "H" level, the internal circuit (stepping motor) is activated.
- Switching the input signal U/D should be performed while the input level on the CK side is "L".

Input circuit configuration (PD, EXT, F/H, EMG)

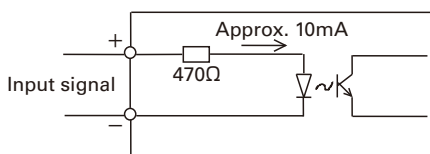

Timing of command pulse, step angle selection, and FULL/HALF selection input signal

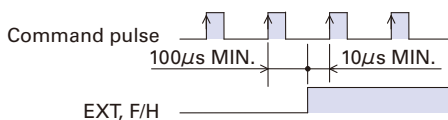

- Shaded area indicates internal photo coupler "ON".
- EXT input signal
EXT photo coupler "ON" enables a function by external F/H input signal.
EXT photo coupler "OFF" enables the setting of a number of micro steps by main unit's rotary switch S.S.
- F/H input signal
F/H photo coupler "ON" sets HALF step (2-division) operation.
F/H photo coupler "OFF" sets FULL step (1-division) operation.
- Refer to switching EXT and F/H input signal in the [FULL/HALF input signal, command pulse, and step angle select].
- When switching the step angle by EXT and F/H input signal, the phase origin LCD may not turn ON and the phase origin monitor output may not output when stop.
Refer to the MON output in the [Output Interface].

Output interface (BUSY, MON, AL)

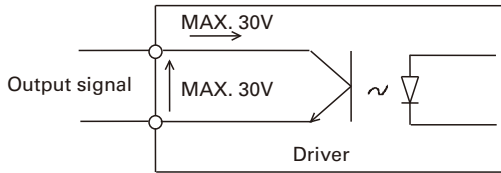

MON output

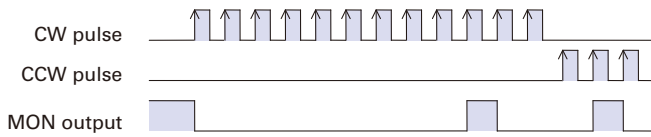

- When the motor excitation phase is at the phase origin (power ON status), the photo coupler is turned "ON", and the upper D.P of status LED turns on synchronously.
- Output from MON is set to on at every 3.6 degrees of motor output shaft from phase origin.

When changing the division setting by F/H input signal.

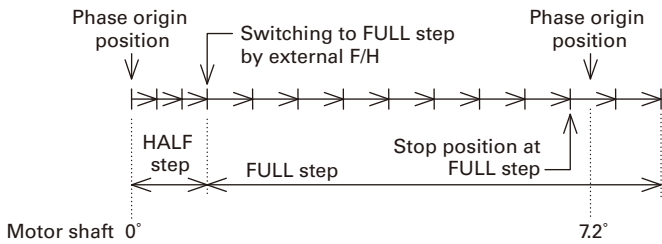

- When changing the motor division setting by the external input signal and the rotary switch as shown in the example below, the motor cannot stop where MON output signal can be output. Take this into consideration when using the MON output signal.

Connections and Signals

External Wiring Diagram

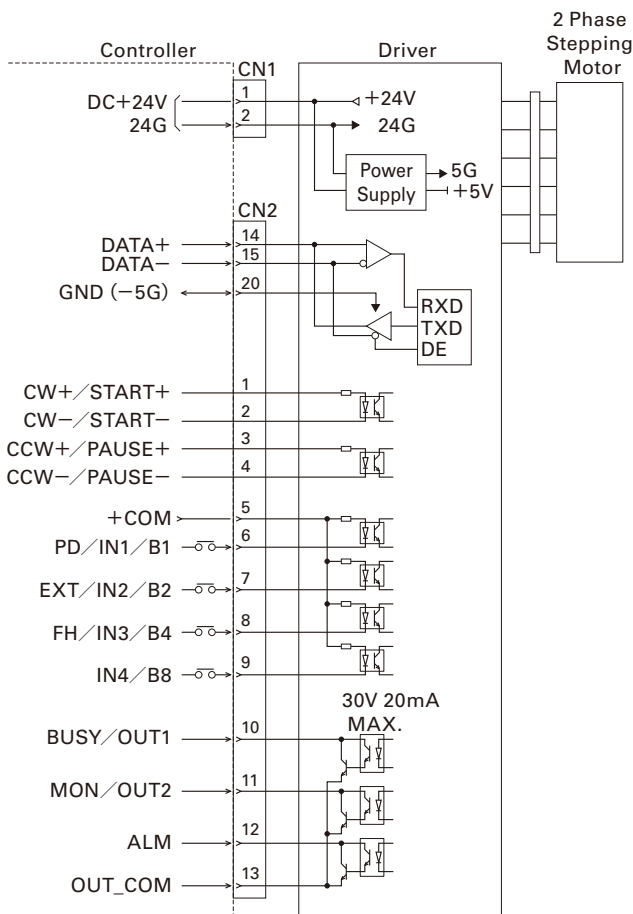

Wiring

■ Specification Summary of Input/Output Signals (Parallel I/F mode)

Signal	Reference Designation	Pin Number	Function Summary
Program drive Start/Stop	START + START -	1 2	Commands the start and stop of program driving. Internal photo coupler on ...Program driving start Internal photo coupler off ...Program driving stop
Program pause	PAUSE + PAUSE -	3 4	When START signal on, a pause in program driving is commanded. Internal photo coupler on ...Program driving pause Internal photo coupler off ...Program driving pause release
General-purpose input common	+ COM	5	Input signal common of the 6 to 9 pins DC5V is input.
Alarm clear signal (standard)	ALMC	6	Recoverable alarms are cleared. Internal photo coupler off → on...Alarm clear
General-purpose input 1	IN1	6	This is a general-purpose input signal that can be used by program driving. Internal photo coupler on ...General purpose input 1 on Internal photo coupler off ... General purpose input 1 off
Program number selection bit 1	B1	6	The program number is selected along with other bits. (Subordinate bit) Internal photo coupler on...Corresponding bit 1 Internal photo coupler off... Corresponding bit 0
Emergency stop input	EMG	6	The emergency stop signal is input. Internal photo coupler on...No emergency stop Internal photo coupler off...Emergency stop
Origin signal	ORG	6	The origin signal used for the return to origin operation is input. Internal photo coupler on...Origin signal on Internal photo coupler off ... Origin signal off
+ direction overtravel signal	+ OT	7	An overtravel signal in the + direction is input. Internal photo coupler on ...+ direction overtravel not arrived Internal photo coupler off ...+ direction overtravel arrived
General-purpose input 2	IN2	7	This is a general-purpose input signal that can be used by program driving. Internal photo coupler on ...General purpose input 2 on Internal photo coupler off ... General purpose input 2 off
Program number selection bit 2	B2	7	The program number is selected along with other bits. (The second bit from the subordinate) Internal photo coupler on...Corresponding bit 1 Internal photo coupler off... Corresponding bit 0
Emergency stop input	EMG	7	The emergency stop signal is input. Internal photo coupler on...No emergency stop Internal photo coupler off...Emergency stop
Origin signal	ORG	7	The origin signal used for the return to origin operation is input. Internal photo coupler on...Origin signal on Internal photo coupler off ... Origin signal off
Alarm clear signal	ALMC	7	Recoverable alarms are cleared. Internal photo coupler off → on...Alarm clear
- direction overtravel signal	- OT	8	An overtravel signal in the - direction is input. Internal photo coupler on ... - direction overtravel not arrived Internal photo coupler off ... - direction overtravel arrived
General-purpose input 3	IN3	8	This is a general-purpose input signal that can be used by program driving. Internal photo coupler on ...General purpose input 3 on Internal photo coupler off ... General purpose input 3 off
Program number selection bit 4	B4	8	The program number is selected along with other bits. (The third bit from the subordinate) Internal photo coupler on...Corresponding bit 1 Internal photo coupler off... Corresponding bit 0
Emergency stop input	EMG	8	The emergency stop signal is input. Internal photo coupler on...No emergency stop Internal photo coupler off...Emergency stop

Signal	Reference Designation	Pin Number	Function Summary
Origin signal	ORG	8	The origin signal used for the return to origin operation is input. Internal photo coupler on...Origin signal on Internal photo coupler off ... Origin signal off
Alarm clear signal	ALMC	8	Recoverable alarms are cleared. Internal photo coupler off → on...Alarm clear
Emergency stop signal	EMG	9	The emergency stop signal is input. Internal photo coupler on ...No emergency stop Internal photo coupler off ...Emergency stop
General-purpose input 4	IN4	9	This is a general-purpose input signal that can be used by program driving. Internal photo coupler on ...General purpose input 4 on Internal photo coupler off ... General purpose input 4 off
Program number selection bit 8	B8	9	The program number is selected along with other bits. (The fourth bit from the subordinate) Internal photo coupler on ... Corresponding bit 1 Internal photo coupler off ... Corresponding bit 0
Origin signal	ORG	9	The origin signal used for the return to origin operation is input. Internal photo coupler on...Origin signal on Internal photo coupler off ... Origin signal off
Alarm clear signal	ALMC	9	Recoverable alarms are cleared. Internal photo coupler off → on...Alarm clear
During motor operation	BUSY	10	The operation status of the motor is output. Internal photo coupler on ...During motor operation Internal photo coupler off ...During motor stop
During program execution	PEND	10	The execution status of the program is output. Internal photo coupler on ...During program execution Internal photo coupler off ...Program execution complete
Zone signal	ZONE	10	Turns on when the current position is inside the coordinates that were set beforehand.
During program execution	PEND	11	The execution status of the program is output. Internal photo coupler on ...During program execution Internal photo coupler off ...Program execution complete
During motor operation	BUSY	11	The operation status of the motor is output. Internal photo coupler on ...During motor operation Internal photo coupler off ...During motor stop
Zone signal	ZONE	11	Turns on when the current position is inside the coordinates that were set beforehand.
Alarm output	ALM	12	When various alarm circuits operate in the driver, an external signal is output. At this time, the stepping motor becomes non excited status.
Output signal common	OUT_COM	13	It is for the output signal common.
DATA +	DATA +	14	It is for the serial signal.
DATA -	DATA -	15	It is for the serial signal.

■ Specification Summary of Input/Output Signals (Serial I/F mode)

Signal	Reference Designation	Pin Number	Function Summary
General-purpose input common	+ COM	5	Input signal common of the 6 to 9 pins DC 5V is input.
Alarm clear signal (standard)	ALMC	6	Recoverable alarms are cleared. Internal photo coupler off → on → Alarm clear
General-purpose input 1	IN1	6	This is a general-purpose input signal that can be used by program driving. Internal photo coupler on … General purpose input 1 on Internal photo coupler off … General purpose input 1 off
Emergency stop input	EMG	6	The emergency stop signal is input. Internal photo coupler on → No emergency stop Internal photo coupler off → Emergency stop
Origin signal	ORG	6	The origin signal used for the return to origin operation is input. Internal photo coupler on → Origin signal on Internal photo coupler off → Origin signal off
+ direction overtravel signal	+ OT	7	An overtravel signal in the + direction is input. Internal photo coupler on … + direction overtravel not arrived Internal photo coupler off … + direction overtravel arrived
General-purpose input 2	IN2	7	This is a general-purpose input signal that can be used by program driving. Internal photo coupler on … General purpose input 2 on Internal photo coupler off … General purpose input 2 off
Emergency stop input	EMG	7	The emergency stop signal is input. Internal photo coupler on → No emergency stop Internal photo coupler off → Emergency stop
Origin signal	ORG	7	The origin signal used for the return to origin operation is input. Internal photo coupler on → Origin signal on Internal photo coupler off → Origin signal off
Alarm clear signal	ALMC	7	Recoverable alarms are cleared. Internal photo coupler off → on → Alarm clear
- direction overtravel signal	- OT	8	An overtravel signal in the - direction is input. Internal photo coupler on … - direction overtravel not arrived Internal photo coupler off … - direction overtravel arrived
General-purpose input 3	IN3	8	This is a general-purpose input signal that can be used by program driving. Internal photo coupler on … General purpose input 3 on Internal photo coupler off … General purpose input 3 off
Emergency stop input	EMG	8	emergency stop signal is input. Internal photo coupler on → No emergency stop Internal photo coupler off → Emergency stop
Origin signal	ORG	8	The origin signal used for the return to origin operation is input. Internal photo coupler on → Origin signal on Internal photo coupler off → Origin signal off
Alarm clear signal	ALMC	8	Recoverable alarms are cleared. Internal photo coupler off → on → Alarm clear
Emergency stop signal	EMG	9	The emergency stop signal is input. Internal photo coupler on → No emergency stop Internal photo coupler off → Emergency stop
General-purpose input 4c	IN4	9	This is a general-purpose input signal that can be used by program driving. Internal photo coupler on … General purpose input 4 on Internal photo coupler off … General purpose input 4 off
Origin signal	ORG	9	The origin signal used for the return to origin operation is input. Internal photo coupler on → Origin signal on Internal photo coupler off → Origin signal off
Alarm clear signal	ALMC	9	alarms are cleared. Internal photo coupler off → on → Alarm clear
During motor operation	BUSY	10	The operation status of the motor is output. Internal photo coupler on → During motor operation Internal photo coupler off → During motor stop
During program execution	PEND	10	The execution status of the program is output. Internal photo coupler on … During program execution Internal photo coupler off … Program execution complete

Signal	Reference Designation	Pin Number	Function Summary
Zone signal	ZONE	10	on when the current position is inside the coordinates that were set beforehand.
During program execution	PEND	11	The execution status of the program is output. Internal photo coupler on … During program execution Internal photo coupler off … Program execution complete
During motor operation	BUSY	11	The operation status of the motor is output. Internal photo coupler on → During motor operation Internal photo coupler off → During motor stop
Zone signal	ZONE	11	Turns on when the current position is inside the coordinates that were set beforehand.
Alarm output	ALM	12	When various alarm circuits operate in the driver, an external signal is output. At this time, the stepping motor becomes non excited status.
Output signal common	OUT_COM	13	It is for the output signal common.
DATA +	DATA +	14	It is for the serial signal.
DATA -	DATA -	15	It is for the serial signal.

■ Specification Summary of Input/Output Signals (Pulse train I/F mode)

Signal	Reference Designation	Pin Number	Function Summary
CW pulse input (Standard)	CW + CW -	1 2	When "2 input mode", Input drive pulse rotating CW direction.
Pulse train input	CK + CK -	1 2	When "1 input mode", Input drive pulse train for motor rotation.
CCW pulse input (Standard)	CCW + CCW -	3 4	When "2 input mode", Input drive pulse rotating CCW direction.
Rotational direction input	U / D + U / D -	3 4	When "1 input mode", Input motor rotational direction signal. Internal photo coupler ON → CW direction Internal photo coupler OFF → CCW direction
General-purpose input common	+ COM	5	Input signal common of the 6 to 9 pins DC5V is input.
Power down input	PD	6	Inputting PD signal will cut off (power off) the current flowing to the Motor (With dip switch select, change to the Power low function is possible). PD input signal on (internal photo coupler on) … PD function is valid. PD input signal off (internal photo coupler off) … PD function is invalid.
Step angle select input	EXT	7	FULL/HALF select input will become valid by inputting EXT signal. EXT input signal on (internal photo coupler on) … External input signal F/H is valid EXT input signal off (internal photo coupler off) … Main body rotary switch S.S is valid
FULL/HALF select input	F / H	8	When EXT input signal on (internal photo coupler on), F/H input signal on (internal photo coupler on) … HALF step F/H input signal off (internal photo coupler off) … FULL step
—	—	9	Reserved
During motor operation	BUSY	10	The operation status of the motor is output. Internal photo coupler on … During motor operation Internal photo coupler off … During motor stop
Phase origin monitor output	MON	11	When the excitation phase is at the origin (in power on) it turns on. When FULL step, ON once for 4 pulses, when HALF step, ON once for 8 pulses.
Alarm output	ALM	12	When alarm circuits actuated inside the Driver, outputs signals to outside. Then the Stepping motor becomes unexcited status.
Output signal common	OUT_COM	13	It is for the output signal common.

* As for the Motor rotational direction, CW direction is regard as the clockwise revolution, and CCW direction is regard as the counterclockwise revolution by viewing the Motor from output shaft side.

Set up

Function Select Dip Switch

The functions according to the specification can be selected with this Dip switch.

Confirm the ex-factory setting as follows.

	OFF	ON	
1 F/R	<input type="checkbox"/>	<input type="checkbox"/>	OFF 2 input mode (CW/CCW pulse)
2 LV	<input type="checkbox"/>	<input type="checkbox"/>	OFF Micro step operation
3 PD	<input type="checkbox"/>	<input type="checkbox"/>	OFF Power OFF
4 Reserved	<input type="checkbox"/>	<input type="checkbox"/>	OFF Not available. Do not turn ON.
5 I. SEL	<input type="checkbox"/>	<input type="checkbox"/>	OFF Pulse stream I/F mode
6 S. SEL	<input type="checkbox"/>	<input type="checkbox"/>	

For parallel I/F mode or serial I/F mode

The communication speed of serial communication is set.

Switch	Set value	Communication speed (bps)		
		9,600	19,200	38,400
F/R	OFF	✓	✓	✓
	ON			
LV	OFF	✓	✓	
	ON			✓
PD	OFF	✓		✓
	ON		✓	

* The setting change after the power supply is turned on is invalid. It does not function as a F/R, LV, and PD.

* The communication speed of pulse stream I/F mode is fixed at 9600bps.

For pulse stream I/F mode

1 Input mode select (F/R)

Input pulse mode selection

This switch setting is only effective in pulse stream I/F mode.

F/R	Input pulse mode
ON	1 input mode (CK,U/D)
OFF	2 input mode (CW,CCW)

2 Low vibration mode select (LV)

Low vibration and smooth operation is enabled even by the rough resolution setting (e.g. 1 division, 2 division).

This switch setting is only effective in pulse stream I/F mode. For parallel I/F mode and serial I/F mode, this is usually a low vibration operation.

LV	Operation
ON	Low vibration operation
OFF	Micro step operation

* When LV select is ON (low vibration mode), operational process of driving pulse will be carried out inside the Driver. Therefore, the Motor movement delays for the time of 3.2ms pulse per input pulse. Note that depending upon the combined Motor, load, driving profile and etc, it may take a while until the shaft is adjusted when the Motor stops. (In parallel I/F mode and serial I/F mode there is no delay)

3 Power down select (PD)

Select the Motor winding current value when inputting the power down signal. This switch setting is only effective in pulse stream I/F mode.

PD	Motor winding current
ON	Current value by rotary switch STP (Power Low)
OFF	0A (Power OFF)

* PD function (the setting selected by PD of the function select dip switch) is enabled by PD input signal ON (built-in photo coupler ON) of Input/Output signal connector (CN2). Power down signal input is prior to all the other current settings except for alarms. The operational status may not be maintained such as power swing due to output torque drop or lower operation due to Motor current OFF (unexcited Motor).

Pay extra attention to the input timing of the power down signal in addition that the security device should be installed to the machine.

4 Reserved

5, 6 Operation mode selection (I.SEL, S.SEL)

The operation mode is selected.

I.SEL	S.SEL	Operation mode
OFF	—	Pulse stream I/F mode
ON	OFF	Parallel I/F mode
	ON	Serial I/F mode

* Change the operation mode selection switch after cutting off the driver's power supply.

Rotary switch (RSW) and the mode change switch (PSW)

For pulse stream I/F mode

When it selects the step angle, the driving current is selected, and stops the current is selected, set by combining rotary switch (RSW) and mode change switch (PSW).

1. Step angle select (S.S)

The divisions of the basic step angle (0.9° /step) when micro step driving can be set.

Gradation	0	1	2	3	4	5	6	7
Partition	1	2	2.5	4	5	8	10	20
Gradation	8	9	A	B	C	D	E	F
Partition	25	40	50	80	100	125	200	250

Ex-factory setting is at gradation 1 (division 2)

* The step angle select switch (S.S) and the number of partitions become invalid by EXT input signal ON (built-in photo coupler ON) of Input/Output signal connector (CN2).

2. Driving current select (RUN)

The Motor operation current value can be selected.

Gradation	0	1	2	3	4	5	6	7
Motor current (%)	100 (rated)	95	90	85	80	75	70	65
Gradation	8	9	A	B	C	D	E	F
Motor current (%)	60	55	50	45	40	35	30	25

Ex-factory setting is at gradation 0 (motor current 100%, rated).

* When there is a sufficient extra motor torque, lowering the operation current value will be effective in the lower vibration. The Motor output torque is almost proportional to the current value. When adjusting the operational torque, confirm the sufficient operation margin and determine the Motor current value.

3. Current Select when Stop (STP)

The motor current value when stop and when power down input signal ON (power low function is selected by dip switch) can be selected.

Gradation	0	1	2	3	4	5	6	7
Motor current (%)	100 (rated)	95	90	85	80	75	70	65
Gradation	8	9	A	B	C	D	E	F
Motor current (%)	60	55	50	45	40	35	30	25

Ex-factory setting is set at gradation A (motor current 50%).

* The current setting when stop by STP becomes valid when the Motor stops (approximately 200ms after the last pulse input) and when power down input signal Output torque is approximately proportional to motor current. Pay attention to output torque when stopping motor (especially when dropping Z-axis workload).
* If motor output torque is unconstrained, motor/driver heating can be suppressed by selecting appropriate drive current and stopping current settings.

For parallel I/F mode and serial I/F mode

The slave bureau address of serial communications can be set.

RSW	Slave station address (HEX)
0	0
1	1
:	:
E	E
F	F

Ex-factory setting is set at 0

* The slave station address of the pulse stream I/F mode is fixed at 0.

Stepping motor for vacuum environment Customized Products

DC input set model

Stepping Motor

Stepping motors with integrated drivers

Stepping motor for vacuum environment

Dimensions



Features

- These stepping motors can be driven in a vacuum environment without requiring a vacuum feedthrough. Use as vacuum-compatible actuators while retaining the stepping motor benefits of easy high-precision open-loop control.
- We can customize for a wide range of environment pressures, from low to ultra-high vacuums.
- Available baked at 200°C .
- Size is similar to that of typical stepping motors.

Intended Operating Pressure

Low vacuum			Medium vacuum			High vacuum			Ultra-High vacuum				
10^5	10^4	10^3	10^2	10^1	1	10^{-1}	10^{-2}	10^{-3}	10^{-4}	10^{-5}	10^{-6}	10^{-7}	10^{-8} [Pa]

Applications

Ideal for the following applications. Contact us to discuss your particular application environment needs.

- Semiconductor manufacturing equipment
- Satellite robotics
- Electron microscopes
- Large-scale research facilities such as accelerators, synchrotron radiation analysis equipment, etc.

Motor size

28mm sq. (1.10inch sq.) to ϕ 106mm (ϕ 4.17in)

42mm sq. (1.65inch sq.)

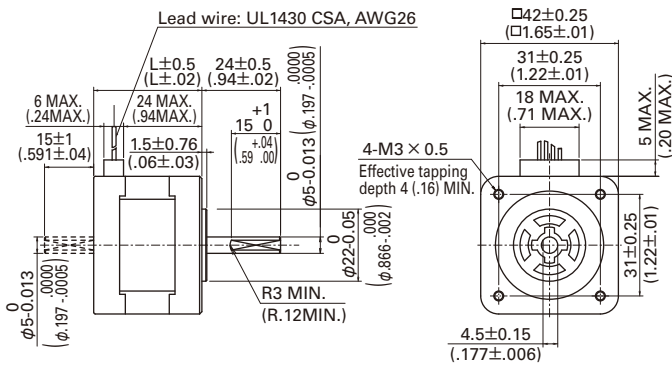

Bipolar

Set model number		Motor model number		Motor length (L)
Single shaft	Double shafts	Single shaft	Double shafts	
-	-	103H5205-5040	103H5205-5010	33 (1.25)
-	-	103H5205-5140	103H5205-5110	33 (1.25)
DB14H521S	DB14H521D	103H5205-5240	103H5205-5210	33 (1.25)
-	-	103H5208-5040	103H5208-5010	39 (1.54)
-	-	103H5208-5140	103H5208-5110	39 (1.54)
DB14H522S	DB14H522D	103H5208-5240	103H5208-5210	39 (1.54)
-	-	103H5209-5040	103H5209-5010	41 (1.61)
-	-	103H5209-5140	103H5209-5110	41 (1.61)
-	-	103H5209-5240	103H5209-5210	41 (1.61)
-	-	103H5210-5040	103H5210-5010	48 (1.89)
-	-	103H5210-5140	103H5210-5110	48 (1.89)
DB14H524S	DB14H524D	103H5210-5240	103H5210-5210	48 (1.89)

42mm sq. (1.65inch sq.)

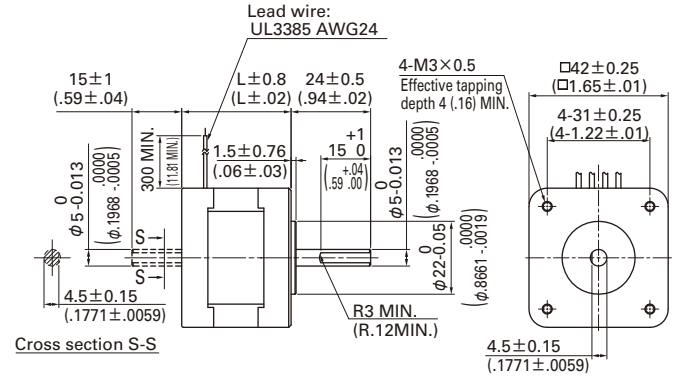

Note: A bipolar motor is illustrated; unipolar motors have six lead wires.

Unipolar

Set model number		Motor model number		Motor length (L)
Single shaft	Double shafts	Single shaft	Double shafts	
DU15S141S	DU15S141D	SH1421-0441	SH1421-0411	33 (1.25)
DU15S142S	DU15S142D	SH1422-0441	SH1422-0411	39 (1.54)
DU15S144S	DU15S144D	SH1424-0441	SH1424-0411	48 (1.89)

Bipolar

Set model number		Motor model number		Motor length (L)
Single shaft	Double shafts	Single shaft	Double shafts	
-	-	SH1421-5041	SH1421-5011	33 (1.25)
DB16S141S	DB16S141D	SH1421-5241	SH1421-5211	33 (1.25)
-	-	SH1422-5041	SH1422-5011	39 (1.54)
DB16S142S	DB16S142D	SH1422-5241	SH1422-5211	39 (1.54)
-	-	SH1424-5041	SH1424-5011	48 (1.89)
DB16S144S	DB16S144D	SH1424-5241	SH1424-5211	48 (1.89)

50mm sq. (1.97inch sq.)

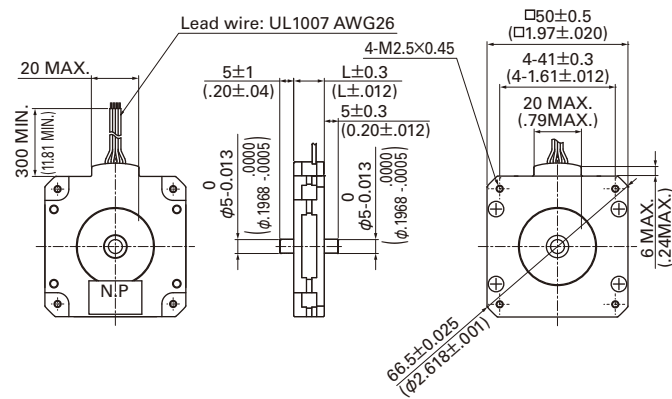

Bipolar

Set model number		Motor model number		Motor length (L)
Single shaft	Double shafts	Single shaft	Double shafts	
-	-	SS2501-8040	SS2501-8010	11.4 (.43)
-	-	SS2502-8040	SS2502-8010	16.4 (.63)

50mm sq. (1.97inch sq.)

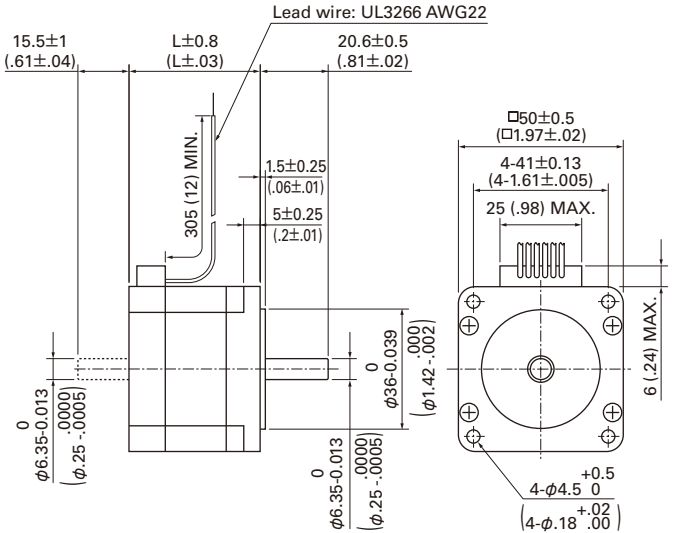

Note: A unipolar motor is illustrated; bipolar motors have four lead wires.

Unipolar

Set model number		Motor model number		Motor length (L)
Single shaft	Double shafts	Single shaft	Double shafts	
-	-	103H6701-0140	103H6701-0110	39.8 (1.57)
-	-	103H6701-0440	103H6701-0410	39.8 (1.57)
-	-	103H6701-0740	103H6701-0710	39.8 (1.57)
-	-	103H6703-0140	103H6703-0110	51.3 (2.02)
-	-	103H6703-0440	103H6703-0410	51.3 (2.02)
-	-	103H6703-0740	103H6703-0710	51.3 (2.02)
-	-	103H6704-0140	103H6704-0110	55.8 (2.20)
-	-	103H6704-0440	103H6704-0410	55.8 (2.20)
-	-	103H6704-0740	103H6704-0710	55.8 (2.20)

Bipolar

Set model number		Motor model number		Motor length (L)
Single shaft	Double shafts	Single shaft	Double shafts	
DB16H671S	DB16H671D	103H6701-5040	103H6701-5010	39.8 (1.57)
DB16H673S	DB16H673D	103H6703-5040	103H6703-5010	51.3 (2.02)
-	-	103H6704-5040	103H6704-5010	55.8 (2.20)

Stepping motors [Unit: mm (inch)]

56mm sq. (2.20inch sq.)

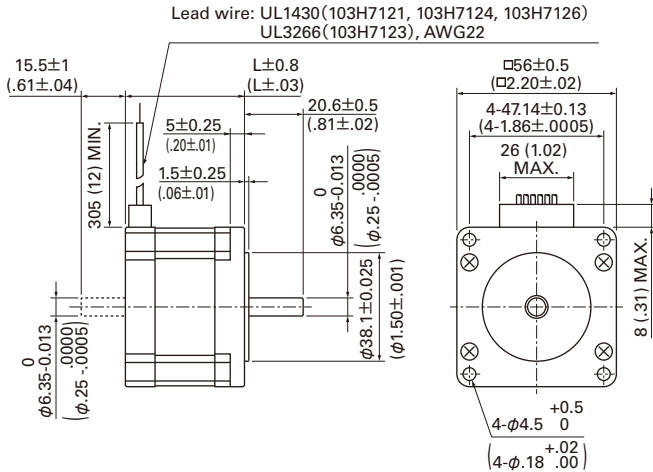

56mm sq. (2.20inch sq.)

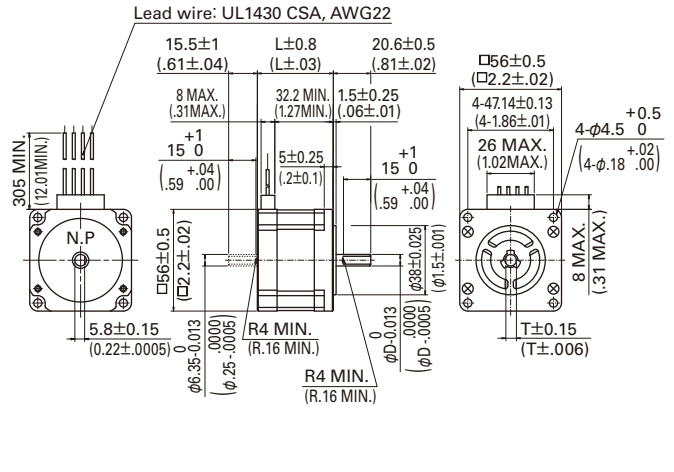

Unipolar

Set model number		Motor model number		Motor length (L)
Single shaft	Double shafts	Single shaft	Double shafts	
-	-	103H7121-0140	103H7121-0110	41.8 (1.65)
DU16H711S	DU16H711D	103H7121-0440	103H7121-0410	41.8 (1.65)
-	-	103H7121-0740	103H7121-0710	41.8 (1.65)
-	-	103H7123-0140	103H7123-0110	53.8 (2.12)
DU16H713S	DU16H713D	103H7123-0440	103H7123-0410	53.8 (2.12)
-	-	103H7123-0740	103H7123-0710	53.8 (2.12)
-	-	103H7124-0140	103H7124-0110	63.8 (2.51)
-	-	103H7124-0440	103H7124-0410	63.8 (2.51)
-	-	103H7124-0740	103H7124-0710	63.8 (2.51)
-	-	103H7126-0140	103H7126-0110	75.8 (2.98)
DU16H716S	DU16H716D	103H7126-0440	103H7126-0410	75.8 (2.98)
-	-	103H7126-0740	103H7126-0710	75.8 (2.98)

Bipolar

Set model number		Motor model number		Motor length (L)	Shaft diameter (D)	DCut thickness (T)
Single shaft	Double shafts	Single shaft	Double shafts			
-	-	103H7121-5640	103H7121-5610	41.8 (1.65)	φ 6.35 (φ 0.25)	5.8 (0.23)
DB16H711S	DB16H711D	103H7121-5740	103H7121-5710	41.8 (1.65)	φ 6.35 (φ 0.25)	5.8 (0.23)
-	-	103H7121-5840	103H7121-5810	41.8 (1.65)	φ 6.35 (φ 0.25)	5.8 (0.23)
-	-	103H7123-5640	103H7123-5610	53.8 (2.12)	φ 6.35 (φ 0.25)	5.8 (0.23)
DB16H713S	DB16H713D	103H7123-5740	103H7123-5710	53.8 (2.12)	φ 6.35 (φ 0.25)	5.8 (0.23)
-	-	103H7123-5840	103H7123-5810	53.8 (2.12)	φ 6.35 (φ 0.25)	5.8 (0.23)
-	-	103H7126-5640	103H7126-5610	75.8 (2.98)	φ 6.35 (φ 0.25)	5.8 (0.23)
DB16H716S	DB16H716D	103H7126-5740	103H7126-5710	75.8 (2.98)	φ 6.35 (φ 0.25)	5.8 (0.23)
-	-	103H7126-5840	103H7126-5810	75.8 (2.98)	φ 6.35 (φ 0.25)	5.8 (0.23)
-	-	103H7128-5640	103H7128-5610	94.8 (3.73)	φ 8 (φ 0.31)	7.5 (0.30)
-	-	103H7128-5740	103H7128-5710	94.8 (3.73)	φ 8 (φ 0.31)	7.5 (0.30)
-	-	103H7128-5840	103H7128-5810	94.8 (3.73)	φ 8 (φ 0.31)	7.5 (0.30)

60mm sq. (2.36inch sq.)

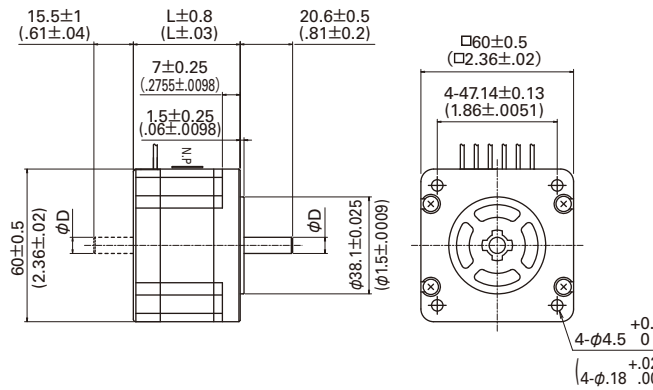

Note: A unipolar motor is illustrated; bipolar motors have four lead wires.

Unipolar

Set model number		Motor model number		Motor length (L)	Shaft diameter (D)
Single shaft	Double shafts	Single shaft	Double shafts		
-	-	SH1601-0440	SH1601-0410	42 (1.65)	φ 6.35 - 0.013 (φ .25 - .0005)
-	-	SH1602-0440	SH1602-0410	54 (2.13)	φ 6.35 - 0.013 (φ .25 - .0005)
-	-	SH1603-0440	SH1603-0410	76 (2.99)	φ 8 - 0.015 (φ .31 - .0006)

Bipolar

Set model number		Motor model number		Motor length (L)	Shaft diameter (D)
Single shaft	Double shafts	Single shaft	Double shafts		
DB16S161S	DB16S161D	SH1601-5240	SH1601-5210	42 (1.65)	φ 6.35 - 0.013 (φ .25 - .0005)
DB16S162S	DB16S162D	SH1602-5240	SH1602-5210	54 (2.13)	φ 6.35 - 0.013 (φ .25 - .0005)
-	-	SH1603-5240	SH1603-5210	76 (2.99)	φ 8 - 0.015 (φ .31 - .0006)

60mm sq. (2.36inch sq.)

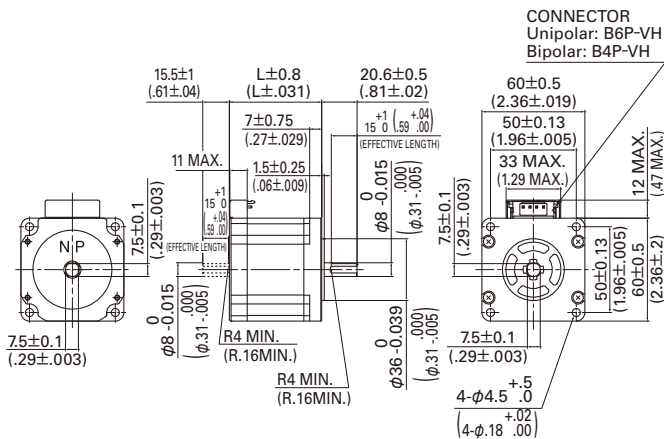

Note: A bipolar motor is illustrated.

60mm sq. (2.36inch sq.)

(Dimensions for attaching NEMA23 are interchangeable)

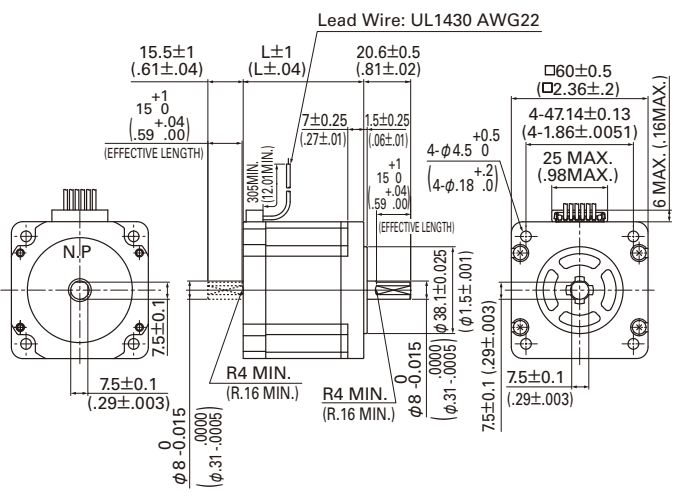

Note: A unipolar motor is illustrated; bipolar motors have four lead wires.

Unipolar

Set model number		Motor model number		Motor length (L)
Single shaft	Double shafts	Single shaft	Double shafts	
-	-	103H7821-0140	103H7821-0110	44.8 (1.76)
-	-	103H7821-0440	103H7821-0410	44.8 (1.76)
-	-	103H7821-0740	103H7821-0710	44.8 (1.76)
-	-	103H7822-0140	103H7822-0110	53.8 (2.12)
-	-	103H7822-0440	103H7822-0410	53.8 (2.12)
-	-	103H7822-0740	103H7822-0710	53.8 (2.12)
-	-	103H7823-0140	103H7823-0110	85.8 (3.38)
-	-	103H7823-0440	103H7823-0410	85.8 (3.38)
-	-	103H7823-0740	103H7823-0710	85.8 (3.38)

Unipolar

Set model number		Motor model number		Motor length (L)
Single shaft	Double shafts	Single shaft	Double shafts	
-	-	103H7821-0160	103H7821-0130	43.5 (1.71)
-	-	103H7821-0460	103H7821-0430	43.5 (1.71)
-	-	103H7821-0760	103H7821-0730	43.5 (1.71)
-	-	103H7822-0160	103H7822-0130	52.5 (2.07)
-	-	103H7822-0460	103H7822-0430	52.5 (2.07)
-	-	103H7822-0760	103H7822-0730	52.5 (2.07)
-	-	103H7823-0160	103H7823-0130	84.5 (3.33)
-	-	103H7823-0460	103H7823-0430	84.5 (3.33)
-	-	103H7823-0760	103H7823-0730	84.5 (3.33)

Bipolar

Set model number		Motor model number		Motor length (L)
Single shaft	Double shafts	Single shaft	Double shafts	
DB16H781S	DB16H781D	103H7821-5740	103H7821-5710	44.8 (1.76)
DB16H782S	DB16H782D	103H7822-5740	103H7822-5710	53.8 (2.12)
DB16H783S	DB16H783D	103H7823-5740	103H7823-5710	85.8 (3.38)
-	-	103H7821-1740	103H7821-1710	44.8 (1.76)
-	-	103H7822-1740	103H7822-1710	53.8 (2.12)
-	-	103H7823-1740	103H7823-1710	85.8 (3.38)

Bipolar

Set model number		Motor model number		Motor length (L)
Single shaft	Double shafts	Single shaft	Double shafts	
-	-	103H7821-5760	103H7821-5730	43.5 (1.71)
-	-	103H7821-1760	103H7821-1730	43.5 (1.71)
-	-	103H7822-5760	103H7822-5730	52.5 (2.07)
-	-	103H7822-1760	103H7822-1730	52.5 (2.07)
-	-	103H7823-5760	103H7823-5730	84.5 (3.33)
-	-	103H7823-1760	103H7823-1730	84.5 (3.33)

Motor cable Unipolar Model number: 4837798-1

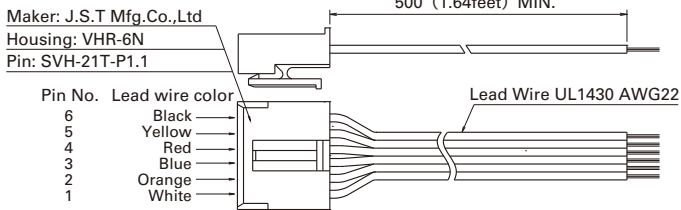

Motor cable Bipolar Model number: 4837961-1

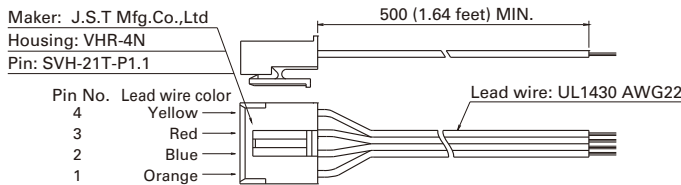

Stepping motors [Unit: mm (inch)]

86mm sq. (3.39inch sq.)

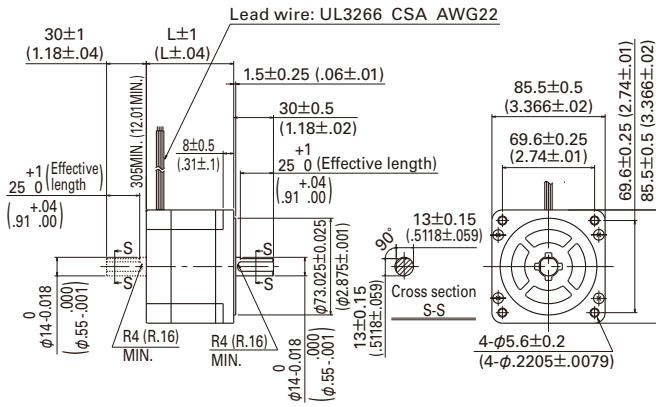

86mm sq. (3.39inch sq.) CE · UL Model

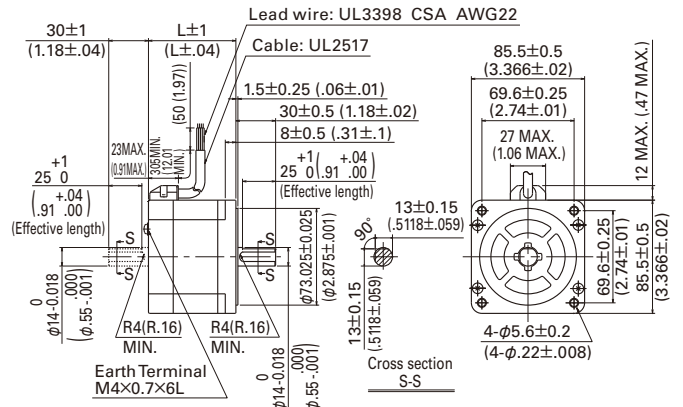

Note: A bipolar motor is illustrated; unipolar motors have six lead wires.

Unipolar

Set model number		Motor model number		Motor length (L)
Single shaft	Double shafts	Single shaft	Double shafts	
—	—	SH2861-0441	SH2861-0411	66 (2.6)
—	—	SH2861-0941	SH2861-0911	66 (2.6)
—	—	SH2862-0441	SH2862-0411	96.5 (3.8)
—	—	SH2862-0941	SH2862-0911	96.5 (3.8)
—	—	SH2863-0441	SH2863-0411	127 (5)
—	—	SH2863-0941	SH2863-0911	127 (5)

Unipolar CE · UL Model

Set model number		Motor model number		Motor length (L)
Single shaft	Double shafts	Single shaft	Double shafts	
—	—	SM2861-0451	SM2861-0421	66 (2.6)
—	—	SM2861-0951	SM2861-0921	66 (2.6)
—	—	SM2862-0451	SM2862-0421	96.5 (3.8)
—	—	SM2862-0951	SM2862-0921	96.5 (3.8)
—	—	SM2863-0451	SM2863-0421	127 (5)
—	—	SM2863-0951	SM2863-0921	127 (5)

Bipolar

Set model number		Motor model number		Motor length (L)
Single shaft	Double shafts	Single shaft	Double shafts	
—	—	SH2861-5041	SH2861-5011	66 (2.6)
—	—	SH2861-5141	SH2861-5111	66 (2.6)
—	—	SH2861-5241	SH2861-5211	66 (2.6)
—	—	SH2862-5041	SH2862-5011	96.5 (3.8)
—	—	SH2862-5141	SH2862-5111	96.5 (3.8)
—	—	SH2862-5241	SH2862-5211	96.5 (3.8)
—	—	SH2863-5041	SH2863-5011	127 (5)
—	—	SH2863-5141	SH2863-5111	127 (5)
—	—	SH2863-5241	SH2863-5211	127 (5)

Bipolar CE · UL Model

Set model number		Motor model number		Motor length (L)
Single shaft	Double shafts	Single shaft	Double shafts	
—	—	SM2861-5051	SM2861-5021	66 (2.6)
—	—	SM2861-5151	SM2861-5121	66 (2.6)
—	—	SM2861-5251	SM2861-5221	66 (2.6)
—	—	SM2862-5051	SM2862-5021	96.5 (3.8)
—	—	SM2862-5151	SM2862-5121	96.5 (3.8)
—	—	SM2862-5251	SM2862-5221	96.5 (3.8)
—	—	SM2863-5051	SM2863-5021	127 (5)
—	—	SM2863-5151	SM2863-5121	127 (5)
—	—	SM2863-5251	SM2863-5221	127 (5)

Stepping drivers [Unit: mm (inch)]

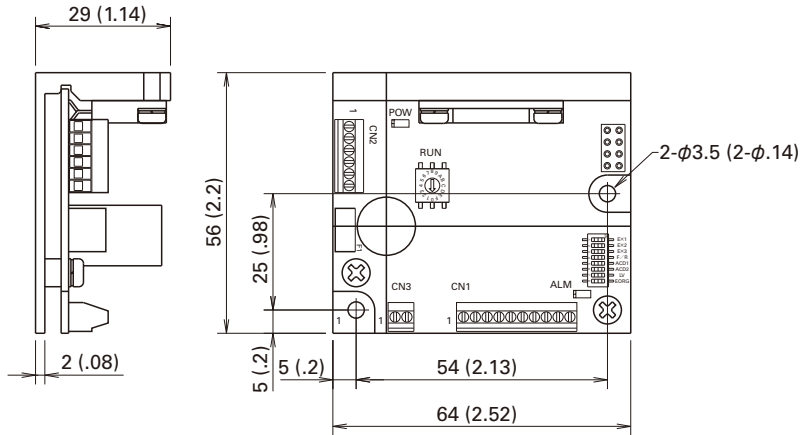

Stepping motors with integrated drivers [Unit: mm (inch)]

42mm sq. (1.65inch sq.)

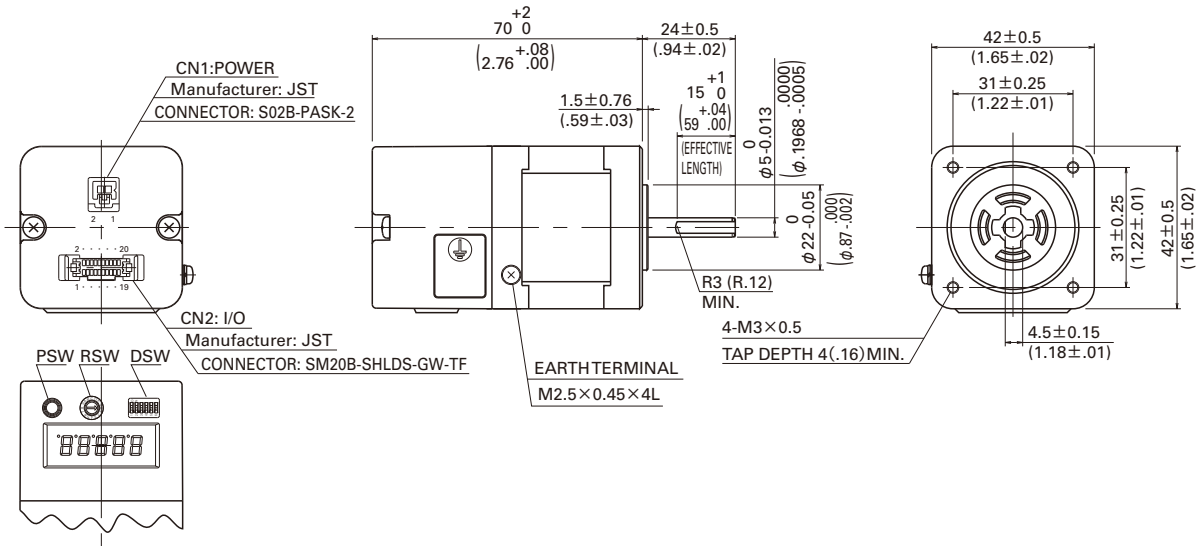

60mm sq. (2.36inch sq.)

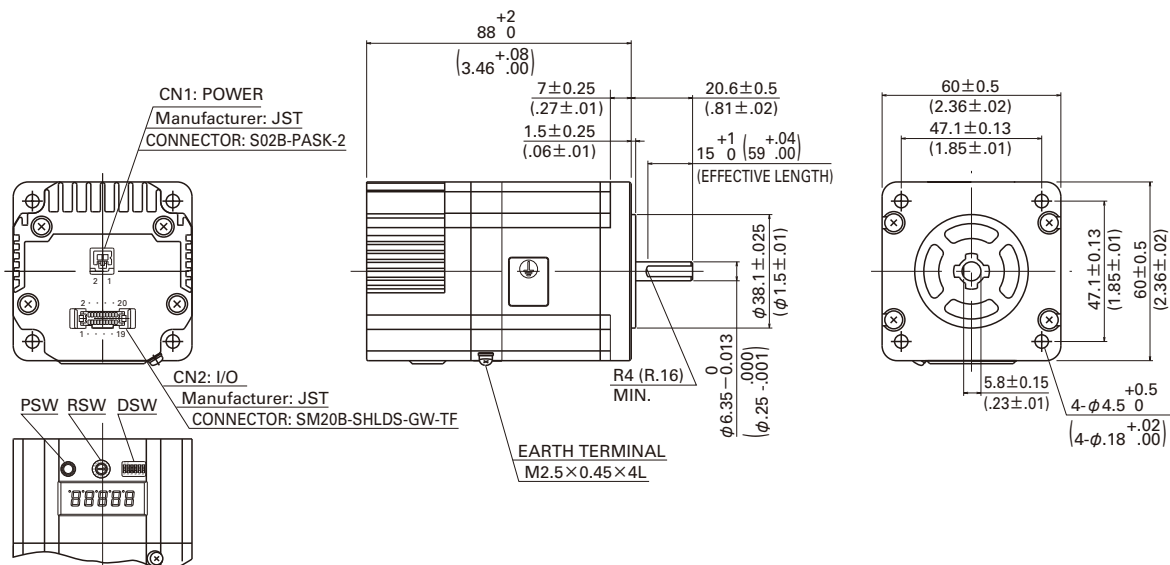

Safety Consideration

The drivers and stepping motors are the products designed to be used for the general industrial devices. When using those, pay enough attention to the following points.

- Read thoroughly the Operation Manual prior to placement, assembly and/or operation in order to use the product properly.
- Refrain from modifying or processing the product in any way.
- Consult with the distributor or professional experts for placement or maintenance services of the product.
- In case of the following uses of the product, contact with us for the special care required to the operation, maintenance and management such as multiplexing the system, installing an emergency electric generator set, or so forth.
 - ① Use for the medical devices concerned with a fatal accident .
 - ② Use for trains, elevators, and so forth that are likely to cause an accident resulting in injury, damage or death.
 - ③ Use in the computer system highly influential to the social life or the public systems.
 - ④ Use in other devices highly influential to maintaining the human safety or the public functions.

In addition to the above, consult with us for use in such a vibration environment as automobile or transportation. Make yourself knowledgeable and familiarize with the devices, safety issues and cautions before handling the product.

Indication by (Warning Label) on the product

Either or all of the following indications are given by the Warning Labels depending on the type of the driver or stepping motor.



This label is stuck near the high voltage part such as the electrically charged or cover-protected section, warning that the place where it is likely to cause an electric shock.



This label is stuck on the place where the driver or stepping motor body should be easily acknowledged, warning that it is likely to cause burns from high temperature.



This label is stuck near the GND terminals of the driver or stepping motor for which grounding is required, suggesting that the terminals should be actually grounded.



This label is stuck for the driver or stepping motor to which the power source is applied in the voltage exceeding the safety standard, drawing attention against the electric shock.

Safety ranks of the cautions

Following four ranks are provided.



DANGER Improper operations or use is most likely to result in serious injury or death.



CAUTION Improper operations or use is likely to result in average or minor injury, or in property damage.

In spite of the cautions with the  CAUTION CAUTION label, it may cause serious results. Either the contents of the labels is describing important cautions to be followed inevitably.



PROHIBITED Indicates what shall not be done.



COMPULSORY Indicates what shall be done.



< General matters >

1. Do not use the product in an explosive, flammable or corrosive atmosphere, watery place or near a combustible material. Doing so may cause injury or fire.
2. Have a person with expert knowledge for performing the transportation, placement, wiring, operation, maintenance or inspection of the product.
Without such knowledge, it may cause an electric shock, injury or fire.
3. Do not work for wiring, maintenance servicing or inspection with the electric power on. Perform either of those five minutes after turning the power off, or otherwise, it may cause an electric shock.
4. When the protective functions of the product is activated, turn the power off immediately and eliminate the cause. If continuing the operation without eliminating the cause, the product may operate improperly and cause injury or a breakdown of the system devices.
5. Stepping motor may run out of order at the operating and stopping occasions, depending on the magnitude of the load. Put the product into use after confirming with the adequate trial test operation in the maximum load conditions that the product performs reliable operation. Doing otherwise may cause a breakdown of the system. (Should the product run out of order in the use to drive upward/downward, it may cause a fall of the load.)
6. Do not touch the internal parts of the driver. Doing so may cause an electric shock.

< Wiring >

7. Do not connect the stepping motor directly with the commercial power outlet. Doing so may cause an electric shock, injury or fire. The power shall be supplied to the stepping motor through the driving circuit.
8. Use the electric power source within the rated input voltage. Using otherwise may cause fire or an electric shock.
9. Connect the driver and stepping motor to the ground. Using without grounding may cause an electric shock.
10. Do not harm, forcibly put a stress, or load a heavy article on the cable or get it caught between the articles. Doing so may cause an electric shock.
11. Perform wiring with the power cable as instructed by the wiring diagram or the Operation Manual. Doing otherwise may cause an electric shock or fire.

< Operation >

12. Be sure not to touch the rotating part of the stepping motor during its operation. Touching it may cause injury.
13. Neither reach or touch the electric terminals while electric power is on. Doing so may cause an electric shock.
14. Never disconnect any of the connectors while electric power is on. Doing so may cause an electric shock and corruption.

< General matters >

1. Prior to placement, operation, maintenance servicing or inspection, be sure to read the Operation Manual and follow the instructions to perform those. Failure to follow the instructions may cause an electric shock, injury or fire.
2. Do not use the driver or the stepping motor outside the specified conditions.
Doing so may cause an electric shock, injury or fire.
3. Do not insert a finger or a thing into the opening of the product. Doing so may cause an electric shock, injury or fire.
4. Do not use the damaged driver or stepping motor. Doing so may cause injury, fire or the like.
5. Use the driver and stepping motor in the designated combination. Using otherwise may cause fire or a trouble.
6. Be careful that the temperature rises in the operating driver, stepping motor or peripheral devices. Failure to be careful may cause a burn.

< Unpacking >

7. Unpack while confirming the ceiling. Failure to do so may cause injury.
8. Confirm if the product is the one having been ordered. Installing an incorrect product may cause a breakdown.

< Wiring >

9. Do not perform measurement of the insulation resistance or withstand insulation voltage of the product. Doing so may cause a breakdown. Instead, contact with us for such inspection.
10. Perform wiring conforming to the technical standards of electric facility or the internal rule. Doing otherwise may cause burning or fire.
11. Ensure that wiring has been correctly done. Operating without correct wiring may cause the stepping motor to run out of control and result in injury.
12. Take insulation process for the attached condenser or the external resistance connection terminals. Failure to do so may cause an electric shock.

< Placement >

13. Do not climb or attach a heavy article on the product. Doing so may cause injury.
14. Neither block nor stuff the aspiration/exhaust vent with a foreign particle. Doing so may cause fire.
15. Follow the instructions for the direction to place. Failure to do so may cause a trouble.
16. Keep a distance as instructed by the Operation Manual for the driver from the inner surface of the control console or other devices. Failure to do so may cause a trouble.
17. Place the product with a great care so as to prevent from the danger such as a tumble or a turnover.



18. Mount the product on an incombustible material such as metal. Doing otherwise may cause fire.
19. Confirm the rotating direction before connecting with the mechanical device. Failure to do so may cause injury or a breakdown.
20. Do not touch the motor output spindle (including the key slot and gears) with a bare hand. Doing so may cause injury.

< Operation >

21. The stepping motor is not equipped with any protective device. Take protective measures using an over-current protective relay, a ground fault interrupter, a protective device from excess temperature, and an emergency stopping device. Failure to do so may cause injury or fire.
22. Do not touch the product for a period after the power is on or has been turned off, since the driver and stepping motor remain in the high temperature. Doing so may cause burns. Especially the temperature rises considerably of the stepping motor depending on the operating conditions. Use the motor on the condition so that its surface temperature becomes 100° C or under.
23. Stop the operation immediately when an emergency occurs. Failure to do so may cause an electric shock, injury or fire.
24. Do not change adjustment to an extreme, for such a change results in the unstable operation. Doing so may cause injury.
25. When conducting the trial operation, make the stepping motor fixed firmly, and confirm the operation by disconnecting with the mechanical system before connecting with it. Failure to do so may cause injury.
26. When the alarm has been activated, eliminate the cause and ensure the safety to resume operation. Failure to do so may cause injury.
27. When the electric power recovers after the momentary interruption, do not approach the devices because the system may re-start operation by itself. (Set the system so as to secure the safety even when it re-start on such occasion.) Failure to do so may cause injury.
28. Confirm that the electric power supply is all proper conforming to the specifications. Failure to do so may cause a trouble.
29. The brake mechanism of the motor with the electro-magnetic brake is to hold the movable section and the motor position. Do not use it as a safety measure, or doing so may cause the breakdown of the system.
30. Fix the key firmly when operating the motor with key individually. Failure to do so may cause injury.

< Maintenance services >

31. Be careful when performing maintenance services or inspection about the temperature which rises highly in the driver and stepping motor frame. Failure to do so may cause burns.
32. It is recommended to replace the electrolytic condenser of the driver with a new one for securing the preventive measure after using for 5 years, the expected life in the average 40° C. The expected life of the fuse is 10 years in the average 40° C. Thus, the periodical replacement is recommended.
33. Contact with us for repair. If the product is disassembled by the user, it may put it out of action.

< Transportation >

34. Handle the product with care during transportation so as to prevent from the danger such as a tumble or a turnover.
35. Do not hold with the cable or the motor spindle. Doing so may cause a trouble or injury.

< Retirement >

36. When scrapping the driver or stepping motor, treat it for the general industrial waste.



< Storage >

1. Avoid the place exposed to rain or water drops, or in an environment with hazardous gas or liquid for storing the product. Failure to do so may cause a trouble.

< Maintenance services >

2. Do not assemble or repair the product. Doing so may cause fire or an electric shock.

< General matters >

3. Do not remove the rating plate.



< Storage >

1. Store the product within the specified conservation temperature and humidity in the place not exposed to the sun beam.
2. If the driver has been stored for a long period (3 years or longer for a guide), consult with us. The capacitance may have decreased with the electrolytic condenser due to the long period storage, and it may cause a trouble.

< Operation >

3. Install an external emergency stop circuit to turn the power off for the instant halt of operation.
4. Put the product into operation in the specified ambient temperature and humidity.

< Transportation >

5. Excess loading of the product on the carrier may cause the load to fall in pieces. Follow the instructions given outside the package.

To SANYO DENKI Co.,LTD.

Date : _____

Company: _____

Department: _____

Name: _____

Tel: _____

FAX: _____

E-mail: _____

Item	Contents																																																																																																	
①	Name of target equipment	Equipment name, category (transport, processing, test, other)																																																																																																
②	Name of servo axis	Axis name, axial mechanism (horizontal/vertical), brake mechanism (yes/no)																																																																																																
③	Current condition of above axis	Manufacturer Name () Series Name () Motor Capacity () Hydraulic, Mechanical, or New System ()																																																																																																
④	Positioning accuracy	± mm± μm																																																																																																
⑤	Operation pattern	<p>Acceleration α: ___ G: ___ [m/s²] Feeding Speed V: ___ [m/s] Moving Distance D: ___ [m] (Stroke) Time [sec] ← t1 () → ← t2 () → ← t3 () →</p> <p>[Reference formula] $1G=9.8[m/s^2]$, $1[m/s^2] \div 0.1G$ $\alpha[m/s^2]=V[m/sec] \div t1[sec]$ $D[m]=V[m/sec] \times (t1+t2)[sec]$</p>																																																																																																
⑥	Mechanism	Ball-screw/screw-rotation type (horizontal), ball-screw/nut-rotation type (horizontal), rack and pinion (horizontal), belt/chain (horizontal), rotary table, roll feed, instability																																																																																																
⑦	Mechanical structure	<table border="0"> <tr> <td>WT (table mass)</td> <td>kg</td> <td>WL (work mass)</td> <td>kg</td> <td>WA (mass of other drive parts)</td> <td>kg</td> </tr> <tr> <td>WR (rack mass)</td> <td>kg</td> <td>WB (belt/chain mass)</td> <td>kg</td> <td>WC (counterbalance mass)</td> <td>kg</td> </tr> <tr> <td>Fa (external force axial direction)</td> <td>N</td> <td>Fb (ball-screw preload)</td> <td>N</td> <td>T (roll pushing force)</td> <td>N</td> </tr> <tr> <td>Dr1 (drive-side roll diameter)</td> <td>mm</td> <td>Dr2 (follower-side roll diameter)</td> <td>mm</td> <td></td> <td></td> </tr> <tr> <td>Lr1 (drive-side roll length)</td> <td>mm</td> <td>Lr2 (follower-side roll length)</td> <td>mm</td> <td>G (reduction ratio)</td> <td></td> </tr> <tr> <td>JG (speed-reducer inertia)</td> <td>kg·m²</td> <td>JC (coupling inertia)</td> <td>kg·m²</td> <td></td> <td></td> </tr> <tr> <td>JN (nut inertia)</td> <td>kg·m²</td> <td>JO (other motor-axis conversion inertia)</td> <td>kg·m²</td> <td></td> <td></td> </tr> <tr> <td>Db (ball-screw diameter)</td> <td>mm</td> <td>Lb (ball-screw axial length)</td> <td>mm</td> <td>Pb (ball-screw lead)</td> <td>mm</td> </tr> <tr> <td>Dp (pinion/pulley diameter)</td> <td>mm</td> <td>Lp (pinion axial length)</td> <td>mm</td> <td>tp (pulley thickness)</td> <td>mm</td> </tr> <tr> <td>Dt (table diameter)</td> <td>mm</td> <td>Dh (table-support diameter)</td> <td>mm</td> <td>LW (load shift from axis)</td> <td>mm</td> </tr> <tr> <td>Ds (table shaft diameter)</td> <td>mm</td> <td>Ls (table shaft length)</td> <td>mm</td> <td></td> <td></td> </tr> <tr> <td>ρ (specific gravity of ball-screw/pinion/pulley/table-shaft material)</td> <td>kg/cm³</td> <td></td> <td></td> <td></td> <td></td> </tr> <tr> <td>μ (friction coefficient between sheet and shilding-surface/support-section/roll)</td> <td></td> <td>$\rho 1$ (specific gravity of roll-1 material)</td> <td>kg/cm³</td> <td></td> <td></td> </tr> <tr> <td>$\rho 2$ (specific gravity of roll-2 material)</td> <td>kg/cm³</td> <td>κ (internal friction coefficient of preload nut)</td> <td></td> <td></td> <td></td> </tr> <tr> <td>η (mechanical efficiency)</td> <td></td> <td>JL (load inertia of motor-axis conversion)</td> <td>kg·m²</td> <td></td> <td></td> </tr> <tr> <td>TF (friction torque of motor axis conversion)</td> <td>N·m</td> <td>Tu (imbalance torque of motor axis conversion)</td> <td>N·m</td> <td></td> <td></td> </tr> </table>	WT (table mass)	kg	WL (work mass)	kg	WA (mass of other drive parts)	kg	WR (rack mass)	kg	WB (belt/chain mass)	kg	WC (counterbalance mass)	kg	Fa (external force axial direction)	N	Fb (ball-screw preload)	N	T (roll pushing force)	N	Dr1 (drive-side roll diameter)	mm	Dr2 (follower-side roll diameter)	mm			Lr1 (drive-side roll length)	mm	Lr2 (follower-side roll length)	mm	G (reduction ratio)		JG (speed-reducer inertia)	kg·m ²	JC (coupling inertia)	kg·m ²			JN (nut inertia)	kg·m ²	JO (other motor-axis conversion inertia)	kg·m ²			Db (ball-screw diameter)	mm	Lb (ball-screw axial length)	mm	Pb (ball-screw lead)	mm	Dp (pinion/pulley diameter)	mm	Lp (pinion axial length)	mm	tp (pulley thickness)	mm	Dt (table diameter)	mm	Dh (table-support diameter)	mm	LW (load shift from axis)	mm	Ds (table shaft diameter)	mm	Ls (table shaft length)	mm			ρ (specific gravity of ball-screw/pinion/pulley/table-shaft material)	kg/cm ³					μ (friction coefficient between sheet and shilding-surface/support-section/roll)		$\rho 1$ (specific gravity of roll-1 material)	kg/cm ³			$\rho 2$ (specific gravity of roll-2 material)	kg/cm ³	κ (internal friction coefficient of preload nut)				η (mechanical efficiency)		JL (load inertia of motor-axis conversion)	kg·m ²			TF (friction torque of motor axis conversion)	N·m	Tu (imbalance torque of motor axis conversion)	N·m		
WT (table mass)	kg	WL (work mass)	kg	WA (mass of other drive parts)	kg																																																																																													
WR (rack mass)	kg	WB (belt/chain mass)	kg	WC (counterbalance mass)	kg																																																																																													
Fa (external force axial direction)	N	Fb (ball-screw preload)	N	T (roll pushing force)	N																																																																																													
Dr1 (drive-side roll diameter)	mm	Dr2 (follower-side roll diameter)	mm																																																																																															
Lr1 (drive-side roll length)	mm	Lr2 (follower-side roll length)	mm	G (reduction ratio)																																																																																														
JG (speed-reducer inertia)	kg·m ²	JC (coupling inertia)	kg·m ²																																																																																															
JN (nut inertia)	kg·m ²	JO (other motor-axis conversion inertia)	kg·m ²																																																																																															
Db (ball-screw diameter)	mm	Lb (ball-screw axial length)	mm	Pb (ball-screw lead)	mm																																																																																													
Dp (pinion/pulley diameter)	mm	Lp (pinion axial length)	mm	tp (pulley thickness)	mm																																																																																													
Dt (table diameter)	mm	Dh (table-support diameter)	mm	LW (load shift from axis)	mm																																																																																													
Ds (table shaft diameter)	mm	Ls (table shaft length)	mm																																																																																															
ρ (specific gravity of ball-screw/pinion/pulley/table-shaft material)	kg/cm ³																																																																																																	
μ (friction coefficient between sheet and shilding-surface/support-section/roll)		$\rho 1$ (specific gravity of roll-1 material)	kg/cm ³																																																																																															
$\rho 2$ (specific gravity of roll-2 material)	kg/cm ³	κ (internal friction coefficient of preload nut)																																																																																																
η (mechanical efficiency)		JL (load inertia of motor-axis conversion)	kg·m ²																																																																																															
TF (friction torque of motor axis conversion)	N·m	Tu (imbalance torque of motor axis conversion)	N·m																																																																																															
⑧	Speed reducer	Customer-provided (/) Sanyo denki standard (planet/spur/no-backlash-planet /) other (/)																																																																																																
⑨	Encoder type	Encoder type specified (yes / no) Yes: (Wiring saving incremental encoder, battery backup absolute encoder, absolute encoder for incremental system, battery-less absolute encoder) Resolution ()																																																																																																
⑩	Input format	Position, velocity, torque, other ()																																																																																																
⑪	Host equipment (controller)	Sequencer, laptop, customer-developed product, Sanyo dennki-provided, other ()																																																																																																
⑫	Usage environment and other requirements	Cutting, clean-room use, anti-dust measures, other ()																																																																																																
⑬	Estimated production	Single product: () units/month () units/year																																																																																																
⑭	Development schedule	Prototype period: () Year () Month Production period: () Year () Month																																																																																																
⑮	Various measures	Related documentation (already submitted; send later by mail) Visit/PR desired (yes / no) Meeting desired (yes / no)																																																																																																
⑯	Miscellaneous (questions, pending problems, unresolved issues, etc.)																																																																																																	

■ Precautions For Adoption

Failure to follow the precautions on the right may cause moderate injury and property damage, or in some circumstances, could lead to a serious accident. Always follow all listed precautions.

Cautions

- Read the accompanying Instruction Manual carefully prior to using the product.
- If applying to medical devices and other equipment affecting people's lives, please contact us beforehand and take appropriate safety measures.
- If applying to equipment that can have significant effects on society and the general public, please contact us beforehand.
- Do not use this product in an environment where vibration is present, such as in a moving vehicle or shipping vessel.
- Do not perform any retrofitting, re-engineering, or modification to this equipment.
- The products presented in this catalog are meant to be used for general industrial applications. If using for special applications related to aviation and space, nuclear power, electric power, submarine repeaters, etc., please contact us beforehand.

*For any question or inquiry regarding the above, contact our Sales Department.

<http://www.sanyodenki.com>

SANYO DENKI CO., LTD.

1-15-1, Kita-Otsuka, Toshima-ku, Tokyo 170-8451, Japan

Phone: +81 3 3917 5157

SANYO DENKI AMERICA, INC.

468 Amapola Avenue Torrance, CA 90501 U.S.A.

Phone: +1 310 783 5400

SANYO DENKI EUROPE SA.

P.A. Paris Nord II, 48 Allée des Erables-VILLEPINTE, BP.57286, F-95958 ROISSY CDG Cedex, France

Phone: +33 1 48 63 26 61

SANYO DENKI GERMANY GmbH

Frankfurter Strasse 92, 65760 Eschborn, Germany

Phone: +49 6196 76113 0

SANYO DENKI KOREA CO., LTD.

9F 5-2, Sunwha-dong Jung-gu Seoul, 100-130, Korea

Phone: +82 2 773 5623

SANYO DENKI SHANGHAI CO., LTD.

Rm2107-2109, Bldg A, Far East International Plaza, No.319, Xianxia Rd., Shanghai, 200051, China

Phone: +86 21 6235 1107

SANYO DENKI TAIWAN CO., LTD.

Room 1208, 12F, No.96 Chung Shan N, Rd., Sec.2, Taipei 104, Taiwan, R.O.C.

Phone: +886 2 2511 3938

SANYO DENKI (H.K.) CO., LIMITED

Room 2305, 23/F, South Tower, Concordia Plaza, 1 Science Museum Rd., TST East, Kowloon, Hong Kong

Phone: +852 2312 6250

SANYO DENKI SINGAPORE PTE. LTD.

10, Hoe Chiang Road, #14-03A/04, Keppel Towers, Singapore 089315

Phone: +65 6223 1071

The names of companies and/or their products specified in this catalog are the trade names, and/or trademarks and/or registered trademarks of such respective companies.

*Remarks : Specifications Are Subject To Change Without Notice.

CATALOG No. S0832B011 '13.2.IT