

Hinge Wing Safety Interlock Switches



SI-HG63 Series Safety Interlock Switches Attached to a Load-Bearing Hinge



Model SI-HG63FQDR shown



Features

- Safety switch is integrated into a highly robust PBT housing and screwed onto the fine-cast stainless steel hinge.
- Safety switching point is repositionable.
- Right-hinge, left-hinge, and right-angle hinge models available; switches can also be converted to operate from the opposite side.
- A non-switching blank hinge is also available (see page 7).
- Switch components are protected from mechanical impact, for superior performance to actuator-activated safety switches; rated IEC IP67.
- Hinge operates to a full 270° range of motion; safety switching point (guard-closed position) is adjustable over the full 0–270° operating range.
- Hinge can support an axial and radial load of 1200 N (120 Kg).
- When properly interfaced or used with an appropriate controller, two **SI-HG63** switches on an individual gate or guard can achieve safety category 4, per ISO 13849-1 (EN 954-1).
- Typical applications include:
 - Hinged covers and guards to machines
 - Hinged doors and gates in safety fencing systems
 - Modular aluminum framing

Models

Model	Housing Style/ QD Connection	Contact Configuration* (Gate Closed State)	Contact Configuration* (Gate Open State)	Switching Diagram
SI-HG63FQDR	Inline QD With QD facing down, switch is mounted on right side of hinge			<p>Contacts: □ Open ■ Closed ▒ Transition</p>
SI-HG63FQDL	Inline QD With QD facing down, switch is mounted on left side of hinge			
SI-HG63FQDRR	Right-Angle QD With switch body down, switch is mounted on right side of hinge			

*NOTE: Terminals 33 and 34 are non-safety.





Important Information Regarding the Use of Safety Switches

In the United States, the functions that Banner safety switches are intended to perform are regulated by the Occupational Safety and Health Administration (OSHA). Whether or not any particular safety switch installation meets all applicable OSHA requirements depends upon factors that are beyond the control of Banner Engineering Corp. These factors include the details of how the safety switches are applied, installed, wired, operated, and maintained.

Banner Engineering Corp. has attempted to provide complete application, installation, operation, and maintenance instructions. This information is found in the instruction manual packaged with each safety switch. In addition, we suggest that any questions regarding the use or installation of safety switches be directed to the factory applications department at the telephone numbers or address shown below.

Banner Engineering Corp. recommends that safety switches be applied according to the guidelines set forth in international (ISO/IEC) standards listed below. Specifically, Banner Engineering Corp. recommends application of these safety switches in a configuration which meets safety category 4, per ISO 13849-1 (EN954-1).

In addition, the user of Banner safety switches has the responsibility to ensure that all local, state, and national laws, rules, codes, and regulations relating to the use of Banner safety switches in any particular application are satisfied. Extreme care is urged that all legal requirements have been met and that all installations and maintenance instructions are followed.

Application Assistance

Toll Free: 1-888-3-SENSOR (1-888-373-6767)
Email: sensors@bannerengineering.com
Address: 9714 Tenth Avenue North
Minneapolis, MN 55441

U.S. Regulations Applicable to Use of Banner Safety Switches

OSHA Code of Federal Regulations: Title 29, Parts 1900 to 1910

Available from: Superintendent of Documents
Government Printing Office
P.O. Box 371954
Pittsburgh, PA 15250-7954
Tel: 202-512-1800

U.S. Standards Applicable to Use of Banner Safety Switches

ANSI B11 “Standards for Construction, Care, and Use of Machine Tools”

Available from: Safety Director
AMT—The Association for Manufacturing Technology
7901 Westpark Drive
McLean, VA 22102
Tel: 703-893-2900

Applicable European and International Standards

ISO 12100-1/-2 “Safety of Machinery—Basic Concepts, General Principles for Design” (EN 292-1/-2)

ISO 13852 (EN 294) “Safety of Machinery—Safety Distances to Prevent Danger Zones Being Reached by the Upper Limbs”

ISO 13853 (EN 811) “Safety of Machinery—Safety Distances to Prevent Danger Zones Being Reached by the Lower Limbs”

ISO 13849-1 (EN 954-1) “Safety of Machinery—Safety Related Parts of Control Systems”

ISO 13855 (EN 999) “Safety of Machinery—The Positioning of Protective Equipment in Respect to Approach Speeds of Parts of the Human Body”

ISO 14119 (EN 1088) “Safety of Machinery—Interlocking Devices Associated with Guards—Principles for Design and Selection”

IEC/EN 60204-1 “Safety of Machinery—Electrical Equipment of Machines”

IEC/EN 60947-5-1 “Low Voltage Switchgear—Electromechanical Control Circuit Devices”

Available from: Global Engineering Documents
15 Inverness Way East
Englewood, CO 80112-5704
Phone: 1-800-854-7179
Fax: 303-397-2740



WARNING . . .

It must not be possible for personnel to reach any hazard point through an opened guard (or any opening) before hazardous machine motion has completely stopped. Please reference OSHA CFR 1910.217 and ANSI B11 standards (see page 2) for information on determining safety distances and safe opening sizes for your guarding devices.



CAUTION . . . End Stops

Do not use the switch as an end stop.

The operating angle of the switch must be limited by outer end stops.

Mechanical Installation

All mounting hardware is supplied by the user. Fasteners must be of sufficient strength to guard against breakage. Use of permanent fasteners or locking hardware is recommended to prevent loosening or displacement of the actuator and the switch body. The mounting holes in the switch body and the actuator accept M6 screws (see dimension drawings, pages 6 and 7).

Ensure that excessive force is not exerted by the weight and swing of the guard, gate, or door. (See specifications on page 6.)

Position blank hinges (if used) and the hinge switch(es) on the guard or gate while it is in its fully closed and latched position. Verify that the axis of rotation is identical for all hinges used. (Typically, this can be accomplished by using a straight edge along the long flat edge to verify that the switch bodies are parallel.) After the mounting hardware is secure, check the rotation of the guard or gate for misalignment and binding.

NOTE: A safety switch must be installed in a manner that discourages tampering or defeat.

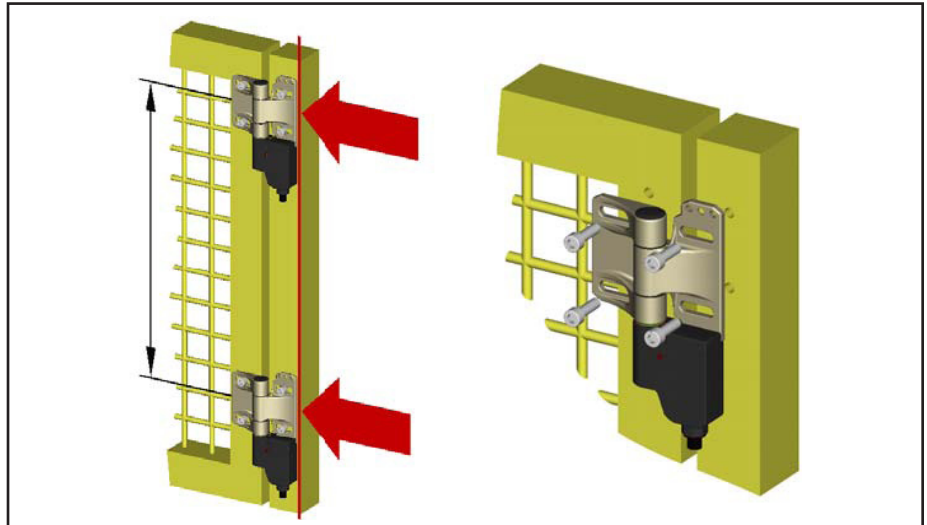

Figure 1. Hinge switch installation

Setting the Switch Point

1. Verify that the hinge switches (and blind hinges, if used) are properly mounted and that the guard or gate swings freely throughout its range of motion without binding. If binding is noticed, repeat the mechanical installation procedures above. See Figure 1.
2. Place the guard in its closed and latched position. Double-check that the installation is correct and the resulting switching action is as expected. See Figure 2.
3. To fix the switching point, move the door or hatch to its closed position and fasten it (e.g., by a stop) to avoid any swiveling.
4. Tighten the set screw with the supplied special bit; max. torque is 2 Nm.
5. The complete visible green color ring in the gap indicates that the fixation process was done correctly.
6. Insert the supplied plugs into the topside of the hinge, and the bottom of the switch, to protect the switch from dirt or debris.
7. Test the function of the switch to verify the proper (expected) operation.

Fine-Adjusting the Switch Point Setting

The adjustment screw can be used to adjust the setting by $\pm 1.5^\circ$. This can be useful to compensate for deviations during installation or later (a misplaced stop or machine vibration, for example). To make the adjustment, insert the supplied screwdriver into the slot of the arrow (Figure 2c) and turn clockwise to increase or counterclockwise to decrease the setting. For most applications, adjust the angle to its functional minimum position.

Relocating the Switch Point Setting or Repositioning the Hinge

The switch point setting can be changed at a later date (for example, to mount in a new location). Changing the setting requires replacement of the red plastic washer (see Accessories for a kit that includes a replacement washer).

The hinge must be removed from the switch component in order to remove the earlier switch point setting. The hinge may then be reinstalled on the same side of the switch as before, or it may be installed to the opposite side. (Thus a left-hand hinge may be converted to a right-hand hinge, and vice versa.)

To perform either task:

1. Remove the screws fastening the hinge to the switch using the supplied tool. (Figure 3a.) Retain the screws for later reuse.
2. Insert a flat-blade screwdriver between the hinge housing and the plastic plug, to gently pry the plastic plugs out. Retain the plastic plugs for later reuse. (Figure 3b.)
3. Remove the hinge portion from the switch. Lift the red plastic washer from the switch. Discard the plastic washer; it cannot be reused. (Figures 3c and 3d.)
4. Align the switch cylinder arrow with mark “A” on the switch housing. (An SW8-size hex wrench is recommended, for easy rotation.) (Figure 3e.)
5. Gently press and turn the switch element into the enclosure, until the switch cylinder arrow aligns with mark “B” on the switch housing. (Figure 3f.)
6. Press the switch element into the enclosure again, until it reaches the internal stop. Install a new red plastic washer (from the accessories bag included with the switch) onto the switch cylinder. (Figure 3g.)
7. If changing the hinge position on the switch (changing from a left hinge to a right, for example), remove the rectangular plug from the switch housing and attach the hinge to that side. Install the hinge onto the switch and rotate 30° to seat. Fasten the switch to the hinge using the supplied tool and the screws removed in step 1. (Figure 3h.) (Countersunk screw max. torque: 2 Nm.)
8. Fix the new switch point setting as required.

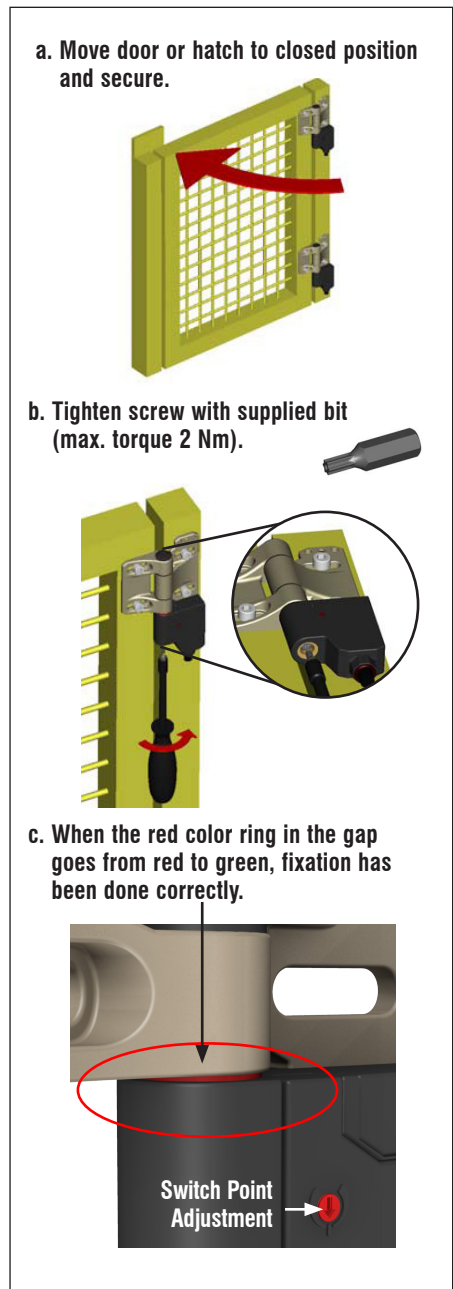

Figure 2. Setting the switch point

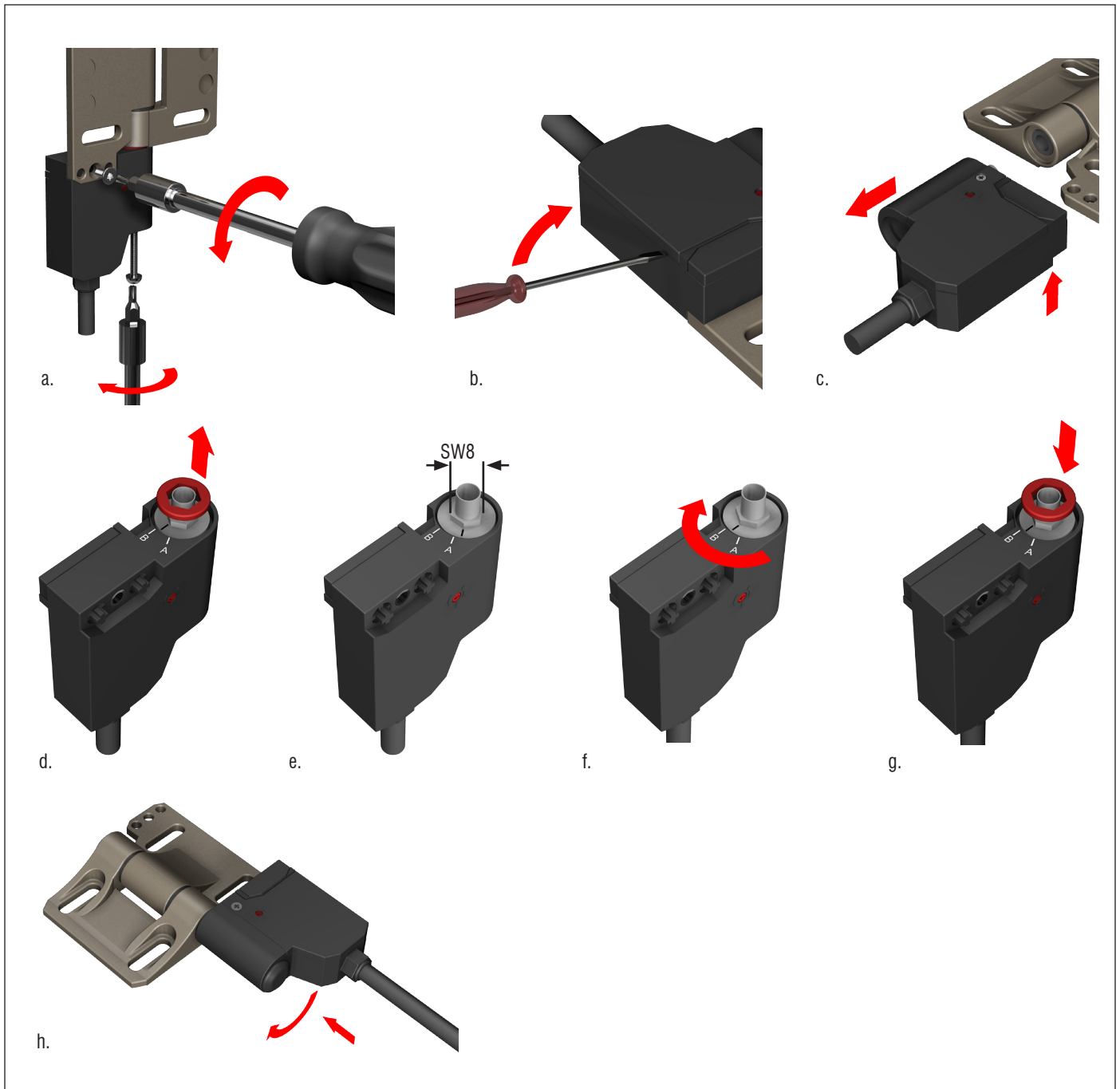

Figure 3. Relocating the switch point setting

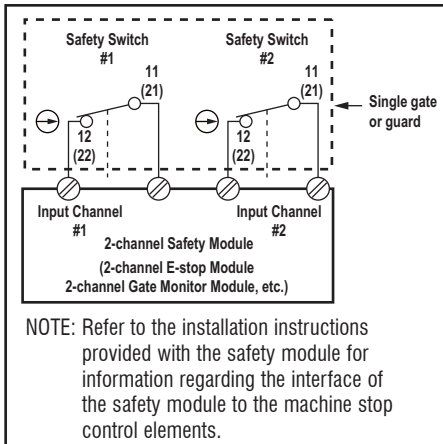

Figure 4. Connect two redundant safety switches per interlock guard to an appropriate 2-channel input safety module.

CAUTION . . . Auxiliary
Electrical Installation
Two safety switches must be used for each interlock guard to achieve control reliability or Safety Category 4 (per ISO 13849-1, EN 954-1) of a machine stop circuit. Use of only one safety switch per interlock guard is not recommended.

In addition, normally-closed safety contacts from each of the two safety switches should be connected to the two separate inputs of a 2-channel safety module or safety interface, as illustrated in Figure 4. This is required to provide monitoring for safety switch contact failure, and to provide the necessary reset routine, as required by IEC 60204-1 and NFPA 79 machine safety standards.

WARNING . . .
Series Connection of Safety Interlock Switches
Monitoring multiple guards with a series connection of multiple safety interlock switches is not a Safety Category 4 Application (per ISO 13849-1, EN 954-1).
A single failure may be masked or not detected at all. When such a configuration is used, procedures must be performed regularly to verify proper operation of each switch.

Electrical Connection

As illustrated in Figure 4, a normally-closed safety contact (i.e., a safety contact that is closed when the actuator is engaged) **from each of two safety switches per interlock guard** must connect to a 2-channel safety module or safety interface in order to achieve a control reliable interface to the master stop control elements of a machine. Examples of appropriate safety modules include 2-channel emergency stop (E-stop) safety modules and gate monitor safety modules.

Two functions of the safety module or safety interface are:

1. To provide a means of monitoring the contacts of both safety switches for contact failure, and to prevent the machine from restarting if either switch fails; and
2. To provide a reset routine after closing the guard and returning the safety switch contacts to their closed position. This prevents the controlled machinery from restarting by simply closing the guard. This necessary reset function is required by ANSI B11 and NFPA 79 machine safety standards.

Use only the positively driven, normally closed safety contact (between pins 11 and 12 or 21 and 22) from each switch for connection to the safety module. A typical use for the non-safety auxiliary contact (between pins 33 and 34) is to communicate with a process controller. Refer to the installation instructions provided with the safety modules for more information regarding the interface of the safety module to the machine stop control elements.

Periodic Checks

Safety switches should be checked at each shift change or machine setup by a *designated person* (see below) for:

- Breakage of the switch body.
- Confirmation that the safety switch is not being used as an end stop.
- Verification that it is not possible to reach any hazard point through an opened guard (or any opening) before hazardous machine motion has completely stopped.
- Verification that the hinge swings freely throughout its total operating range.
- Loosening of mounting hardware.
- Signs of deterioration or damage.
- Signs of tampering or defeat to the switch or to the wiring interface to the machine.

A *designated person* is identified in writing by the employer as being appropriately trained to perform a specified checkout procedure.

Repairs

Do not attempt any repairs to the switch. It contains no field-replaceable components. Return the switch to the factory for warranty repair or replacement.

If it becomes necessary to return a switch to the factory, contact Banner at the number or address listed on the back cover. An applications engineer will attempt to troubleshoot the problem or will issue an RMA (Return Merchandise Authorization) number for your paperwork, and give you the proper shipping address.

Pack the switch carefully. Damage that occurs in shipping is not covered by warranty.

Specifications

Contact Rating	3A @ 230V ac max., 1.0 A @ 24V dc max. 2.5 kV max. transient tolerance NEMA A300 P300
European Rating	Utilization categories: AC15 and DC13 (IEC 90497-5-1) $U_i = 250V$ ac $I_{th} = 5A$
Minimum Switching Speed	5 operations per minute
Switching Angle	N.C. Contact: $\pm 3^\circ$ N.O. Contact: $\pm 9^\circ$ Tolerance for all angles: 1.5°
Mechanical Life	1 million operations
Short Circuit Protection	4 amp Slow Blow, 8 amp Fast Blow. Recommended external fusing or overload protection.
Force Exerted by Guard per Switch	Axial and Radial: 1200 N (264 lbf) max.
Operating Range	0° to 270°
Wire Connections	6-pin Micro-style quick-disconnect (QD) fitting. Cordsets are ordered separately; see page 8.
Construction	Hinge: X22CrNi 17 Switch: PBT
Environmental Rating	NEMA 4, IEC IP67 acc. IEC/EN60529
Operating Conditions	Temperature: -25° to $+70^\circ$ C (-13° to $+158^\circ$ F)
Weight	0.65 kg (1.43 lb)
Application Notes	To avoid excessive radial stress in applications containing large doors, the hinge switch should be mounted either in pairs of two, or in conjunction with a blank hinge (see page 8).
Certifications	

Dimensions

Model SI-HG63FQDR

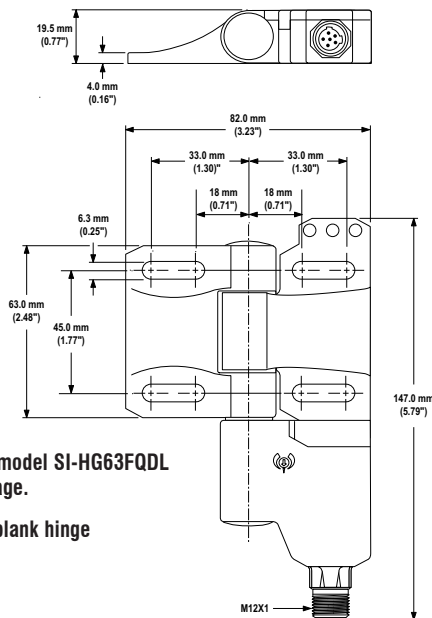

Dimensions for model SI-HG63FQDL are a mirror image.

See page 7 for blank hinge dimensions.

Model SI-HG63FQDRR

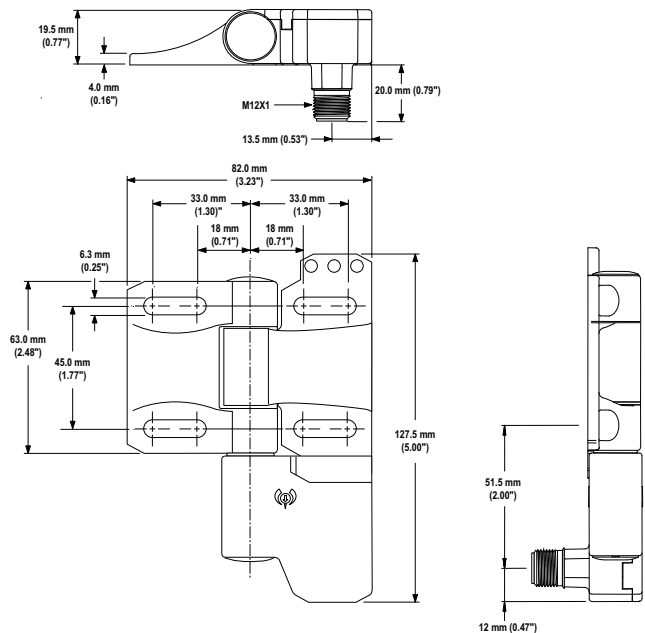

Accessories

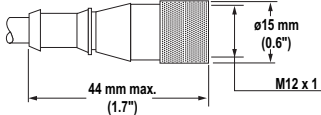
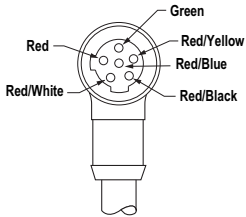
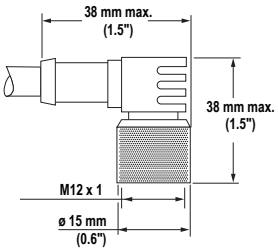
Quick-Disconnect Cordsets				
Style	Model	Length	Dimensions	Pinout
6-Pin Micro-style, Straight	MQEAC-606 MQEAC-615 MQEAC-630	2 m (6.5') 5 m (15') 9 m (30')		
6-Pin Micro-style, Right-Angle	MQEAC-606RA MQEAC-615RA MQEAC-630RA	2 m (6.5') 5 m (15') 9 m (30')		

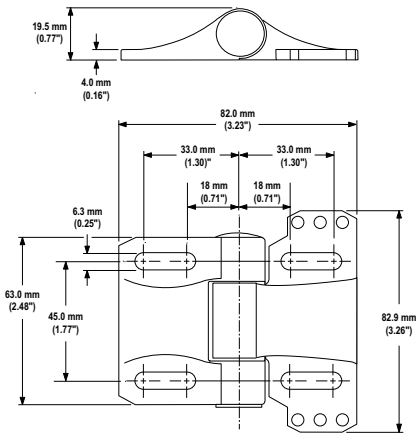
Blank Hinge		
Model	Description	Dimensions
SI-HG63A	Blank hinge; same mechanical specifications as SI-HG63 Series hinge switches, but without the safety switch component	

Replacement Accessory Kit	
Model	Description
SI-HG63-TK1	Replacement accessory kit includes: 2 plugs 1 plastic washer 1 bit 1 screwdriver 1 installation instructions

Banner Engineering Corp. warrants its products to be free from defects in material and workmanship for one year following the date of shipment. Banner Engineering Corp. will repair or replace, free of charge, any product of its manufacture which, at the time it is returned to the factory, is found to have been defective during the warranty period. This warranty does not cover damage or liability for misuse, abuse, or the improper application of the Banner product.

THIS LIMITED WARRANTY IS EXCLUSIVE AND IN LIEU OF ALL OTHER WARRANTIES WHETHER EXPRESS OR IMPLIED (INCLUDING, WITHOUT LIMITATION, ANY WARRANTY OF MERCHANTABILITY OR FITNESS FOR A PARTICULAR PURPOSE), AND WHETHER ARISING UNDER COURSE OF PERFORMANCE, COURSE OF DEALING OR TRADE USAGE.

This Warranty is exclusive and limited to repair or, at the discretion of Banner Engineering Corp., replacement. **IN NO EVENT SHALL BANNER ENGINEERING CORP. BE LIABLE TO BUYER OR ANY OTHER PERSON OR ENTITY FOR ANY EXTRA COSTS, EXPENSES, LOSSES, LOSS OF PROFITS, OR ANY INCIDENTAL, CONSEQUENTIAL OR SPECIAL DAMAGES RESULTING FROM ANY PRODUCT DEFECT OR FROM THE USE OR INABILITY TO USE THE PRODUCT, WHETHER ARISING IN CONTRACT OR WARRANTY, STATUTE, TORT, STRICT LIABILITY, NEGLIGENCE, OR OTHERWISE.**

Banner Engineering Corp. reserves the right to change, modify or improve the design of the product without assuming any obligations or liabilities relating to any product previously manufactured by Banner Engineering Corp.