

LT3748

100V Isolated Flyback Converter

DESCRIPTION

Demonstration circuit 1694A is an isolated flyback converter featuring the LT3748. The demo circuit is designed for a 12V output from a 22V to 75V DC input. The output current is up to 2.5A. The part senses the isolated output voltage directly from the primary side flyback waveform during the off time of the power switch. No third winding, opto-coupler, or signal transformer is required for regulation. A minimum load of approximately 2% of maximum load is required on the output to maintain regulation.

The demo circuit can be easily modified for applications of different input, and output voltage/current, with some pre-designed transformers from vendors such as Würth Electronics, Sumida, Pulse Engineering and Coilcraft. Both EP13 and EFD20 core transformers can be assembled on the board. A two-stage filter is optional for applications requiring very small output ripple.

The LT3748 is a high input voltage isolated flyback controller operating with input supply voltages from 5V to 100V, and 1.9A average gate drive source and sink current. The LT3748 utilizes boundary mode operation to provide a high efficiency, small size solution with improved load regulation of $\pm 5\%$ over the full line, load and temperature ranges. The LT3748 can be used in a wide variety of industrial, automotive, medical, telecom, data-com applications, where regulated isolated output is required.

The LT3748 data sheet gives a complete description of the part, operation and application information. The data sheet must be read in conjunction with this quick start guide for Demo Circuit 1694A.

Design files for this circuit board are available at <http://www.linear.com/demo>

LT, LT, LTC, LTM, Linear Technology and the Linear logo are registered trademarks of Linear Technology Corporation. All other trademarks are the property of their respective owners.

PERFORMANCE SUMMARY

Specifications are at $T_A = 25^\circ\text{C}$

PARAMETER	CONDITIONS	MIN	TYP	MAX	UNITS
Input Voltage Range		22	48	75	V
Output Voltage	$V_{IN} = 22\text{V to } 75\text{V}$ $I_{OUT} = 50\text{mA to } 2.5\text{A}$	11.4	12	12.6	V
Maximum Output Current	$V_{IN} = 22\text{V to } 75\text{V}$	2.5			A
Output Voltage Ripple (Peak-to-Peak)	$V_{IN} = 22\text{V to } 75\text{V}, I_{OUT} = 2.5\text{A}$			420	mV
Switching Frequency	$V_{IN} = 48\text{V}, I_{OUT} = 2.5\text{A}$		289		kHz
Efficiency	$V_{IN} = 48\text{V}, I_{OUT} = 2.5\text{A}$		86.5		%

QUICK START PROCEDURE

Demo circuit 1694A is easy to set up to evaluate the performance of the LT3748. Refer to Figure 1 for proper measurement equipment setup and follow the procedure below.

1. With power off, connect the input power supply to VIN and GND.
2. Connect the load to the terminals VOUT+ and VOUT– on the board. Apply a load between 100mA to 2.5A to the output.
3. Turn on the power at the input. Increase VIN to 22V.

NOTE: Make sure that the input voltage does not exceed 75V.

4. Check for the proper output voltages. The output should be regulated at 12V ($\pm 5\%$).

NOTE: If there is no output, temporarily disconnect the power supply. Make sure that the load is properly connected. If the output voltage is out of spec, make sure minimum load current is applied to the output, the load is not set too high, and the DC power supply does not hit the current limit.

NOTE: If higher operating voltage is required, power components with higher voltage ratings should be used.

NOTE: The LT3748 requires minimum load to maintain good regulation. A Zener diode D4 is placed between VOUT+ and VOUT– to clamp the output voltage to $\sim 13V$ if minimum load requirement is not met. Depending on input voltage and output regulation, a 100mA minimum load is usually sufficient.

5. Once the proper output voltage is established, adjust the input and load within the operating range and observe the output voltage regulation, ripple voltage, efficiency and other parameters.

NOTE: When measuring the input or output voltage ripples, care must be taken to avoid a long ground lead on the oscilloscope probe. Measure the input or output voltage ripple by touching the probe tip directly across the VIN and GND, or VOUT+ and VOUT– terminals. See Figure 2 for proper scope probe technique.

QUICK START PROCEDURE

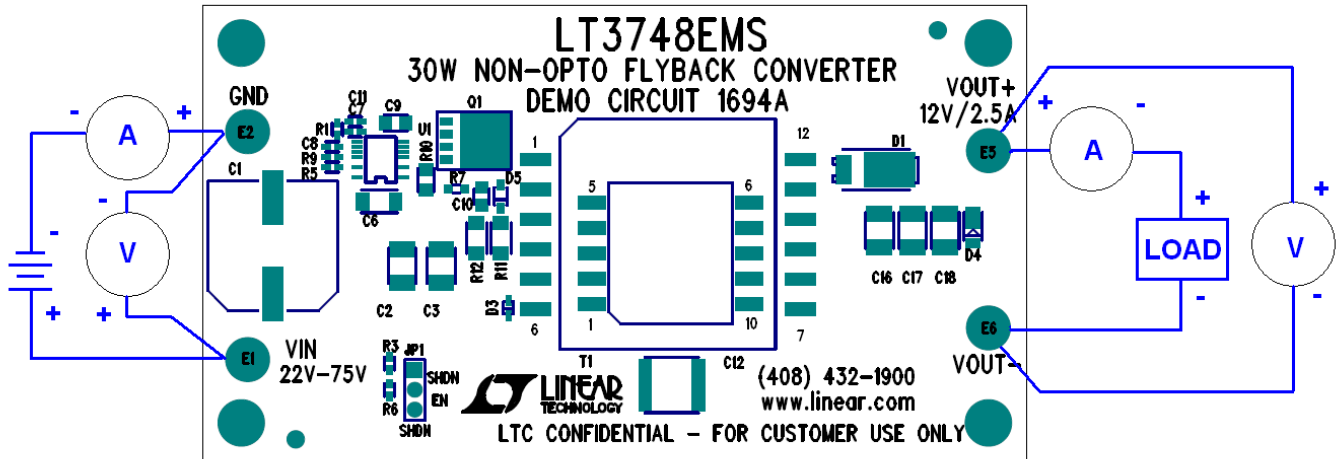

Figure 1. Proper Measurement Equipment Setup

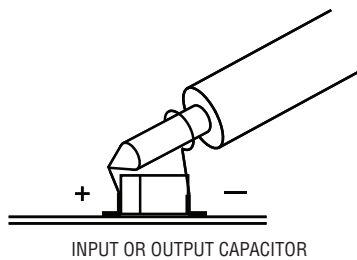

Figure 2. Proper Scope Probe Placement for Measuring Input or Output Ripple

DEMO MANUAL DC1694A

PARTS LIST

ITEM	QTY	REFERENCE	PART DESCRIPTION	MANUFACTURER/PART NUMBER
1	1	C1	CAP., ELECTRO., 100µF, 100V	CHEMI-CON, EMVY101ARA101MKE0S
2	2	C2, C3	CAP., X7R, 2.2µF, 100V, 20% 1210	TDK C3225X7R2A225M
3	1	C6	CAP., X7R, 1.0µF, 100V, 20% 1206	AVX, 12061C105MAT2A
4	1	C7	CAP., X7R, 0.1µF, 16V, 10% 0402	TDK, C1005X7R1C104K
5	1	C8	CAP., COG, 470pF, 50V, 5% 0402	TDK, C1005COG1H471J
6	1	C9	CAP., X5R, 4.7µF, 16V, 20% 0805	AVX, 0805YD475MAT2A
7	1	C10	CAP., COG, 220pF, 100V, 5% 0805	AVX, 08051A221JAT2A
8	1	C11	CAP., X7R, 22nF, 25V, 10% 0402	MURATA, GRM155R71E223KA61D
9	3	C16, C17, C18	CAP., X7R, 22µF, 16V, 20% 1210	TDK, C3225X7R1C226M
10	1	D1	Diode, PDS5100, Power DI-5	DIODE INC., PDS5100-13
11	1	D3	SCHOTTKY BARRIER REC., BAT41, SOD523	ST, BAT41KFILM
12	1	D4	ZENER DIODE, DFLZ13, 13V, PowerDI-123	DIODE INC., DFLZ13-7
13	1	Q1	N-MOSFET, SI7450DP, PowerPAK	VISHAY, SI7450DP-T1-GE3
14	1	R1	RES., CHIP, 12.1k, 1% 0402	VISHAY, CRCW040212K1FKED
15	1	R3	RES., CHIP, 402k, 1% 0402	VISHAY, CRCW0402402KFKED
16	1	R5	RES., CHIP, 6.04k, 1% 0402	NIC, NRC04F6041TRF
17	1	R6	RES., CHIP, 32.4k, 1% 0402	VISHAY, CRCW040232K4FKED
18	1	R7	RES., CHIP, 150k, 1% 0603	VISHAY, CRCW0603150KFKED
19	1	R9	RES., CHIP, 63.4k, 1% 0402	VISHAY, CRCW040263K4FKED
20	1	R10	RES., CHIP, 0.015Ω, 1% 0805	VISHAY, WSL0805R015F
21	2	R11, R12	RES., CHIP, 43Ω, 1/4W, 5% 1206	VISHAY, CRCW120643R0JNEA
22	1	T1	TRANSFORMER	WÜRTH, ELEKTRONIK. 750311607
23	1	U1	I.C. LT3748EMS, MSOP-16	LINEAR TECH., LT3748EMS#TRPBF

Hardware – For Demo Board Only

1	4	E1, E2, E5, E6	TESTPOINT, TURRET, .094" PBF	MILL-MAX, 2501-2-00-80-00-00-07-0
2	1	JP1	3 PIN 0.079 SINGLE ROW HEADER	SAMTEC, TMM103-02-L-S
3	1	XJP1	SHUNT, .079" CENTER	SAMTEC, 2SN-BK-G
4	4	MTG 4 CORNERS	STAND-OFF, NYLON (SNAP ON), 0.25" TALL	KEYSTONE, 8831

Additional Demo Board Circuit Components

1	0	C12 (OPT.)	CAP., 2220	
2	0	C4, C5, C13, C14, C15(OPT.)	CAP., 1210	
3	0	D5 (OPT.)	SCHOTTKY BARRIER REC., SOD-323	
4	0	L1 (OPT.)	INDUCTOR	
5	0	ROUT (OPT.)	RES., 1210	

SCHEMATIC DIAGRAM

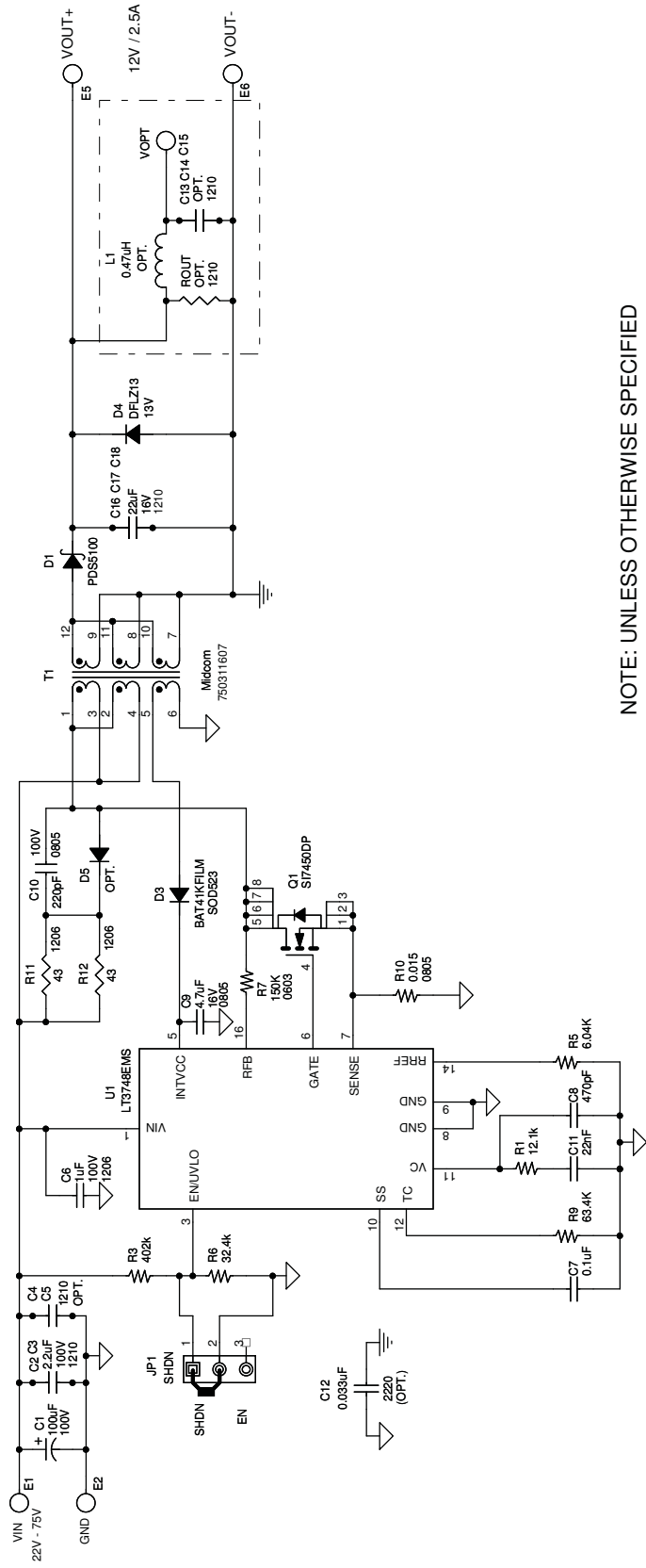

NOTE: UNLESS OTHERWISE SPECIFIED
 1. ALL RESISTORS ARE 0402.
 ALL CAPACITORS ARE 0402.

DEMO MANUAL DC1694A

DEMONSTRATION BOARD IMPORTANT NOTICE

Linear Technology Corporation (LTC) provides the enclosed product(s) under the following **AS IS** conditions:

This demonstration board (DEMO BOARD) kit being sold or provided by Linear Technology is intended for use for **ENGINEERING DEVELOPMENT OR EVALUATION PURPOSES ONLY** and is not provided by LTC for commercial use. As such, the DEMO BOARD herein may not be complete in terms of required design-, marketing-, and/or manufacturing-related protective considerations, including but not limited to product safety measures typically found in finished commercial goods. As a prototype, this product does not fall within the scope of the European Union directive on electromagnetic compatibility and therefore may or may not meet the technical requirements of the directive, or other regulations.

If this evaluation kit does not meet the specifications recited in the DEMO BOARD manual the kit may be returned within 30 days from the date of delivery for a full refund. **THE FOREGOING WARRANTY IS THE EXCLUSIVE WARRANTY MADE BY THE SELLER TO BUYER AND IS IN LIEU OF ALL OTHER WARRANTIES, EXPRESSED, IMPLIED, OR STATUTORY, INCLUDING ANY WARRANTY OF MERCHANTABILITY OR FITNESS FOR ANY PARTICULAR PURPOSE. EXCEPT TO THE EXTENT OF THIS INDEMNITY, NEITHER PARTY SHALL BE LIABLE TO THE OTHER FOR ANY INDIRECT, SPECIAL, INCIDENTAL, OR CONSEQUENTIAL DAMAGES.**

The user assumes all responsibility and liability for proper and safe handling of the goods. Further, the user releases LTC from all claims arising from the handling or use of the goods. Due to the open construction of the product, it is the user's responsibility to take any and all appropriate precautions with regard to electrostatic discharge. Also be aware that the products herein may not be regulatory compliant or agency certified (FCC, UL, CE, etc.).

No License is granted under any patent right or other intellectual property whatsoever. **LTC assumes no liability for applications assistance, customer product design, software performance, or infringement of patents or any other intellectual property rights of any kind.**

LTC currently services a variety of customers for products around the world, and therefore this transaction **is not exclusive**.

Please read the DEMO BOARD manual prior to handling the product. Persons handling this product must have electronics training and observe good laboratory practice standards. **Common sense is encouraged.**

This notice contains important safety information about temperatures and voltages. For further safety concerns, please contact a LTC application engineer.

Mailing Address:

Linear Technology
1630 McCarthy Blvd.
Milpitas, CA 95035

Copyright © 2004, Linear Technology Corporation