

AN10910

Protecting charger interfaces and typical battery charging topologies with external bypass transistors

Rev. 2 — 23 June 2011

Application note

Document information

Info	Content
Keywords	BISS, MOSFET-Schottky, low VCEsat, battery charger, Li-Ion battery (Li-polymer battery), overvoltage protection, reverse polarity protection, ESD protection
Abstract	This application note illustrates how to protect a mobile device charger port against overvoltage and reverse polarity and gives an overview of typical battery charging topologies and how to use NXP Semiconductors protection devices, bipolar and MOS transistors.



Revision history

Rev	Date	Description
2	20110623	<ul style="list-style-type: none">• Table “Document information” updated• Section 7 “Appendix” updated
1	20100428	Initial version

Contact information

For more information, please visit: <http://www.nxp.com>

For sales office addresses, please send an email to: salesaddresses@nxp.com

1. Introduction

This application note describes a complete solution for battery charging in mobile devices. This includes how to charge a Li-Ion battery with typical battery charger topologies, particularly with external bypass transistors and ways to effectively protect against overvoltage and overcurrent from the charger connector.

2. Battery charging via USB interface

2.1 Chinese battery charging standard (YDT1591-2006)

This standard describes an AC-to-DC power adapter with a standard USB type A output connector, allowing different vendors to share common AC-to-DC adapters or allow the handset to be charged via a standard PC USB port.

This will enable customers to carry only one cable to charge their handsets when USB ports are available.

The idea behind this is to reduce the overall volume of AC-to-DC adapters, reduce the Bill Of Material (BOM) cost and improve the “think green” factor.

The electrical specifications of the common AC-to-DC adapters are:

- 5 V output voltage (5% tolerance)
- 300 mA to 1800 mA charging current (PC USB port can offer 500 mA/900 mA)
- included overvoltage protection for voltages higher than 6 V

The battery charger circuit is located in the handset. To make sure that the handset can draw more than 500 mA (five unit loads) from the power adapter, the D+ and D– lines must be shorted inside the adapter.

2.1.1 PC USB port

The power distribution of USB devices is divided into different classes. With this separation the classes can be simplified into different unit loads. A unit load is defined to be 100 mA in USB 2.0 and 150 mA into USB 3.0. After configuration the maximum number of loads is five or six (500 mA or 900 mA) in USB 2.0 and USB 3.0 respectively. For configuration, communication with a PC must often be established to ensure so-called high-power, bus-powered function. A USB 3.0 port may support the USB charging specifications (D+/D– shorted).

Note that the USB 2.0 power distribution requirements are mandatory when a USB 3.0 device is operating in USB 2.0 modes (high-speed, full-speed or low-speed).

2.2 Micro-USB connector in smart phone

Beginning in 2010, with a deadline of 2012, all data transfer capable mobile handsets must use a micro-USB connector as the battery charging interface.

This agreement was signed by ten supplier of mobile handsets and network service providers in June 2009. In February 2009 seventeen partners published a memorandum on a volunteer basis.

The idea behind is similar to the chinese battery charging standard, where any device can be charged by a common AC-to-DC adapter or a PC USB port.

Today's mobile handset volume is between 350 million to 400 million units, with a renew rate of approximately 180 million mobile handsets per year. 25% of today's total volume are capable of data communication or can be connected to a PC. In addition the energy efficiency of the AC-to-DC adapter will be improved. All these changes will reduce up to 51.000 tonnes of excess AC-to-DC adapters.

2.3 V_{BUS} electrical characteristics

Table 1. DC electrical characteristics

Symbol	Parameter	Min	Max	Unit
Supply voltage				
Downstream connector				
V _{BUS}	bus supply voltage	4.45	5.25	V
Upstream connector				
V _{BUS}	bus supply voltage	4.0	-	V
Supply current				
I _{CCPRT}	high-power hub port (out) supply current	500/900	-	mA
I _{CCUPT}	low-power hub port (out) supply current	100/150	-	mA
I _{CCHPF}	high-power function (in) supply current	-	500/900	mA
I _{CCLPF}	low-power function (in) supply current	-	100/150	mA
I _{CCINIT}	unconfigured function/hub (in) supply current	-	100/150	mA
I _{CCSH}	suspended high-power device supply current	-	2.5	mA

2.4 General USB requirements

Depending on the communication speed of the USB interface, different prerequisites apply for protection devices that are placed at this interface. [Table 2](#) lists limits for capacitive load on the differential data lines of the USB port.

Table 2. USB differential data line requirements

Interface speed	maximum bit rate	min	max	unit
Low speed	1.5 MB/s	200 ^[1]	450 ^[1]	pF
Full speed	10 MB/s	-	150 ^[2]	pF
High speed	480 MB/s	-	3 ^[3]	pF
Super speed	5 GB/s	-	0.5 ^[3]	pF

[1] Total capacitance of cable and device on D+ or D- lines

[2] Total capacitance of a downstream facing port including cable connector and transceiver.

[3] Approximate value. Not specified by the USB standard.

3. Charger interface and USB protection

Whether a mobile device is charged via the USB port or via a discrete charger connector incorrect polarity or a too high voltage applied to this input poses a threat to the charger circuit and the Power Management Unit (PMU) of the mobile device. In addition to the danger of accidentally applying the wrong charging voltages, the USB/charger port can be subject to ElectroStatic Discharge (ESD) strikes.

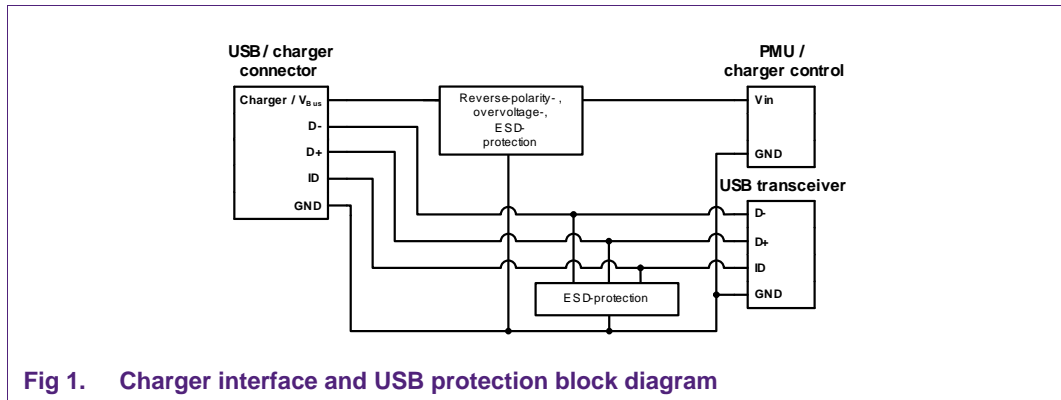

Fig 1. Charger interface and USB protection block diagram

As shown in [Figure 1](#) a complete protection solution for the USB and charger port consists of two blocks. The first block protects the USB V_{BUS} or charger interface against reverse polarity and overvoltage. The second block protects the USB data lines and the downstream components against damage from ESD. The subsequent sections illustrate the protection concepts of these blocks in more detail.

3.1 Reverse polarity protection

In case the charger voltage is accidentally supplied in reverse polarity a PMU and any other downstream circuit needs to be properly protected in order to survive with no damage. A simple and yet effective concept providing this functionality is depicted in [Figure 2](#).

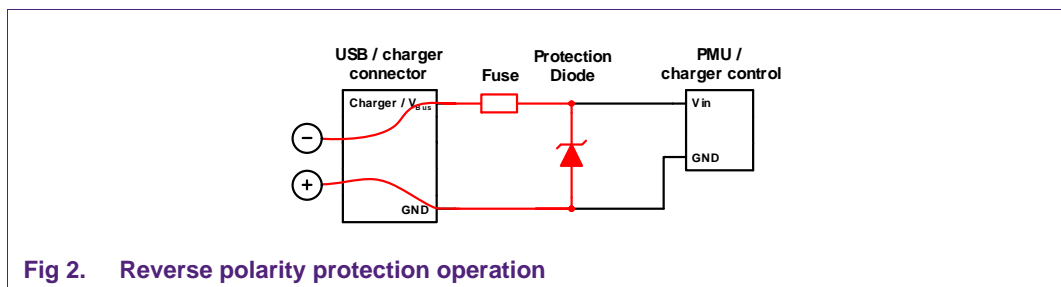

Fig 2. Reverse polarity protection operation

The positive voltage supplied to the GND input of the charger can pass through the forward biased protection diode and the protective fuse, back to the charger negative pole. In this concept the protection diode needs to be able to conduct high currents only until the fuse clears. Fast reacting fuses can clear in 100 ms. [Section 3.4](#) describes protection diodes that are able to conduct up to 5 A for the necessary period of time.

The transient negative voltage that can be observed behind a diode used as reverse polarity protection can be approximated below.

(1)

$$V_{diode} = (I \cdot R_{on}) + V_f$$

For a diode with $R_{on} = 0,268 \Omega$ and $V_f = 0.85 V$ that is operating forward biased in linear region at room temperature, the resulting voltage for a current of $I = 5 A$ is $V_{diode} = 1.65 V$.

3.2 Overvoltage protection

Given the multitude of accessories that are available to replace originally supplied chargers, the threat of a voltage being accidentally applied that is too high is omnipresent. A simple solution means to limit the overvoltage is by adding a Zener diode with a breakdown voltage above the required working voltage.

Figure 3 shows the operation principle of an overvoltage protection based on a Zener diode. A high voltage applied to the charger / V_{BUS} terminal sets the diode into breakdown mode once the diode breakdown voltage is reached. Subsequently the voltage at the PMU / charger input is limited to the breakdown voltage of the diode.

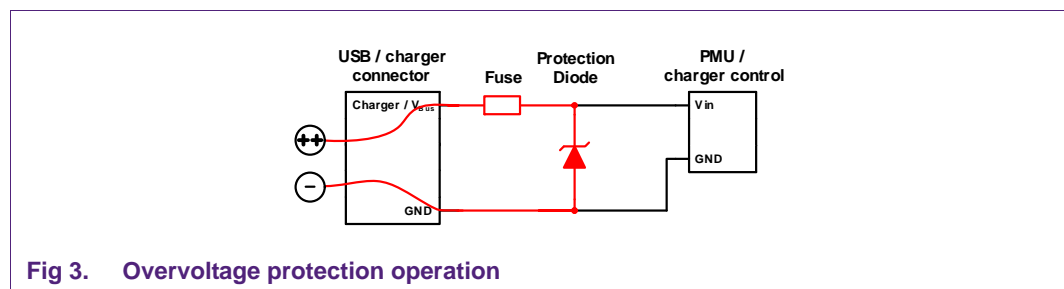

Fig 3. Overvoltage protection operation

If not already present for reverse polarity protection (see Section 3.1), a fuse or Positive Temperature Coefficient (PTC) element should be placed in the supply path. This limits the current if, for example, defective charger supplying the primary voltage is connected and the continuous current that passes via the Zener diode exceeds the limit imposed by the maximum power dissipation.

3.3 USB data ESD protection

While for low speed and full speed USB the constraints for applying additional ESD protection on the differential data lines are relaxed, a high-speed USB port specifies additional capacitance to a much lower value.

3.3.1 Rail-to-rail concept for low capacitance ESD protection

A common architecture utilized to build low capacitance ESD protection devices is the so-called ‘rail-to-rail’ diode concept, which shunts ESD transients from Input/Output (I/O) lines into the ground or power supply ‘rails.’

While some implementations comprise simply of the rail-to-rail diodes themselves, the typical NXP Semiconductors’ solution also contains an additional Zener diode in parallel to the rail-to-rail diode string. This minimizes the clamping voltages by routing all ESD current (positive and negative strikes) back to ground and also to eliminate external components.

The principle of operation of the rail-to-rail concept is illustrated in [Figure 4](#)

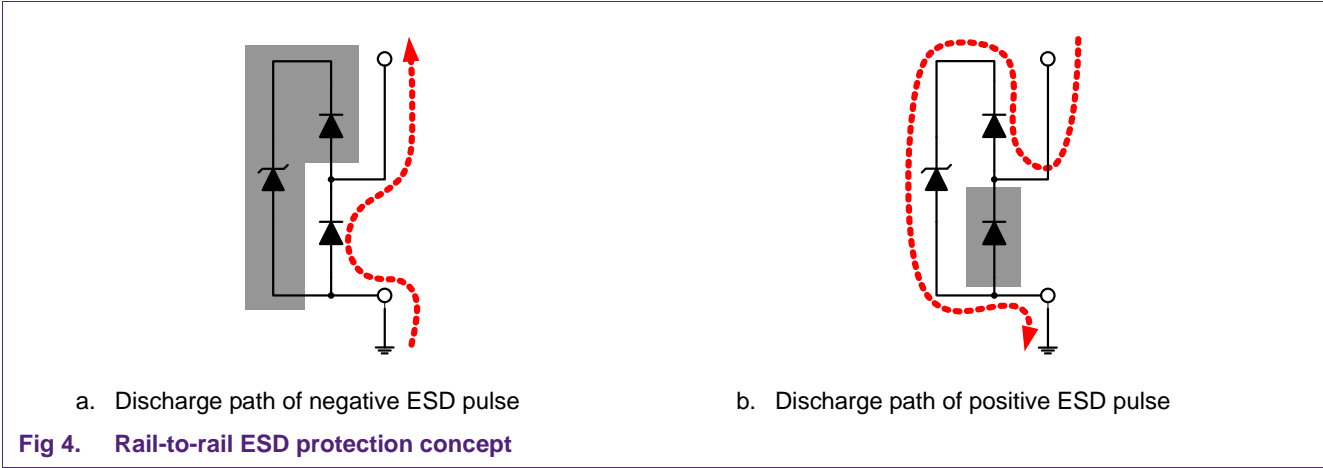

With the rail-to-rail concept, a negative ESD strike on the I/O pin will cause one rail-to-rail diode (the lower diode at the flash sign in [Figure 4](#), left side) to become forward biased, thereby transferring the ESD strike through the lower diode to ground.

A positive discharge strike will cause the other rail-to-rail diode (the upper diode at the flash sign in [Figure 4](#), right side) to become forward biased transferring the discharge to the cathode of the Zener diode that will clamp voltages exceeding its breakdown voltage by the ESD strike to ground.

3.3.2 USB data line ESD protection with rail-to-rail devices

A common technique to provide such a low capacitive ESD protection, for example with a line capacitance below 1.5 pF, is the rail-to-rail ESD protection architecture. [Figure 5](#) shows how a four-channel rail-to-rail ESD protection device can be used to protect all the lines of a USB On-The-Go (OTG) port.

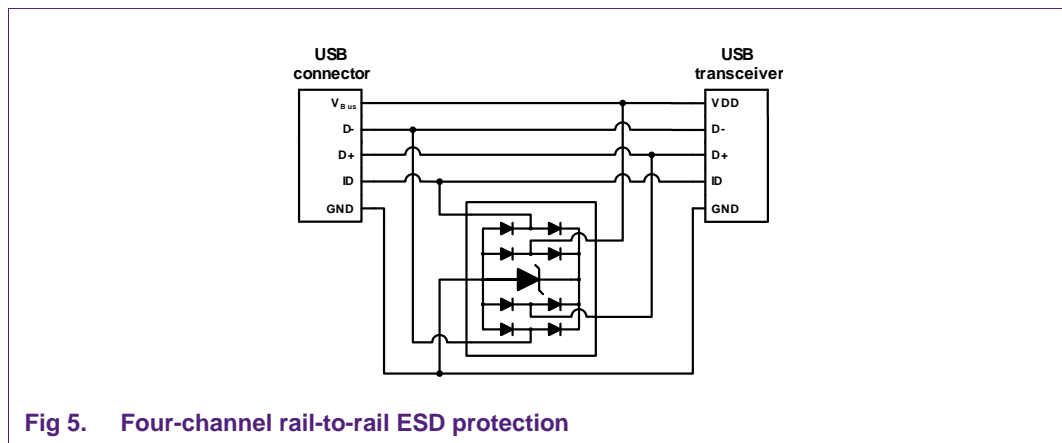

The influence of a low capacitance rail-to-rail protection device on the data transmission can be very small. [Figure 6](#) shows the eye diagram of a high-speed USB transmission captured on the D+/D- lines with and without 1 pF rail-to-rail ESD protection applied. Comparing the two measurements illustrates that the influence of this kind of low capacitance ESD protection is negligible.

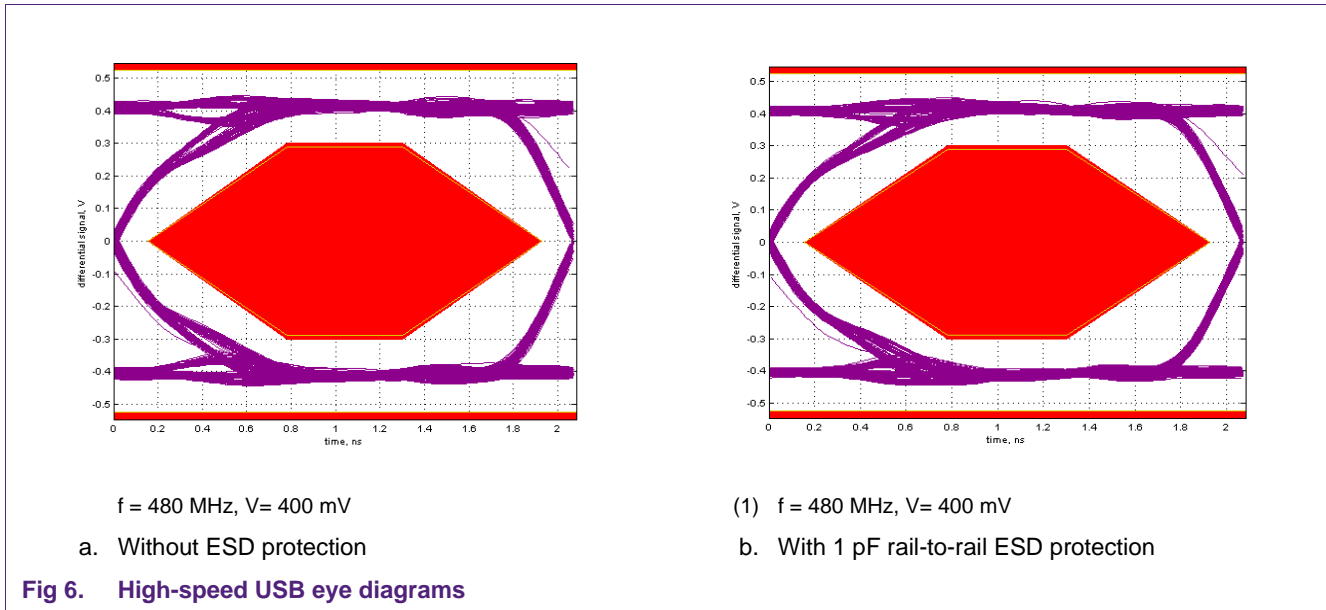

3.4 Protection devices

NXP offers a wide range of protection devices in order to protect against ESD, overvoltage and reverse polarity at a charger interface. These products can be used to realize simple but effective protection concepts as described in the previous section. [Table 5](#) in [Section 7](#) lists a number of products that meet the special requirements of this application.

One product in the comparison table that deserves special attention is IP4389CX4 as it offers a complete reverse polarity and overvoltage protection solution by integrating a fast reacting fuse.

Products that are ideally suited to protecting USB data lines are listed in [Table 4](#) of [Section 7](#). Further information on USB data line protection can also be found in AN10753.

4. Li-Ion batteries

Li-Ion batteries have some advantages compared to Ni-based batteries, like NiCd or NiMH batteries.

- High average operating cell voltage of 3.6 V, instead of 1.2 V (Ni-based batteries)
- High energy density - smaller and lighter batteries
- Lower self-discharge rates
- Little or no memory effect

For these reasons Li-Ion batteries are widely used in mobile applications. On the other hand Li-Ion batteries must be protected against undervoltage, overvoltage, over current and over temperature. Therefore battery management and system monitoring are built into battery packs and most PMU also measure the battery temperature.

Li-Ion batteries need a different charging algorithm compared to Ni-based batteries. This algorithm is called CC/CV (constant current/constant voltage)-algorithm.

The CC/CV charging algorithm is shown in [Figure 7](#).

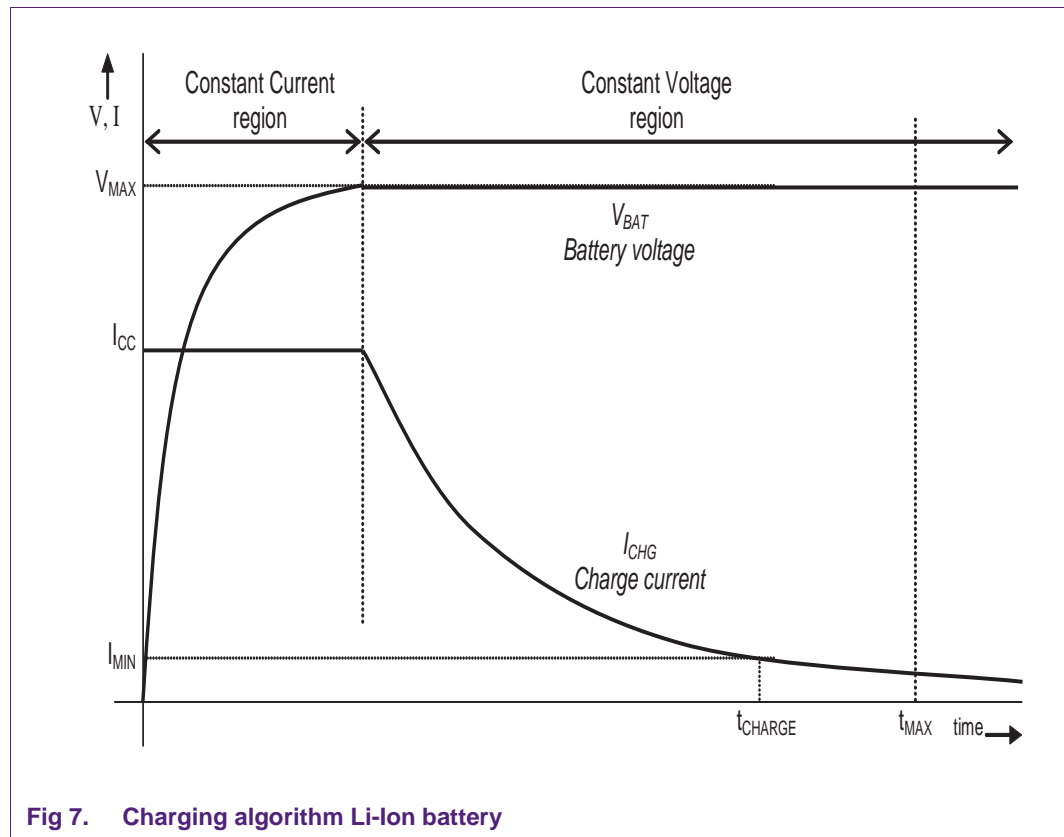

Fig 7. Charging algorithm Li-Ion battery

The value of V_{MAX} and I_{CC} depends on the type of battery that is used. The maximum charge rate in CC mode is 1C, where 1C indicates the capacity of the battery e.g. 1000 mAh. The value of V_{MAX} is typically in the range of 4.1 to 4.2 volts.

During the CV mode the voltage is constant and the charge current decreases as the battery is charged. There are two possibilities to terminate the charging process. First when the charge current drops below the I_{MIN} . Alternatively, a fixed total charging time (t_{MAX}) could be used to stop the charging process.

For the CC/CV charging, there are different modes available, depending on the PMU:

- **Idle mode:** No valid charger adapter is connected. Once a charger adapter is detected most PMUs will enter the qualification mode. The PMU will return to Idle mode when the end-of-charge condition is reached.
- **Qualification mode:** This mode is used for qualifying a discharged battery. Most PMUs remain in qualification mode as long as the battery voltage is below the $V_{VERYLOWBAT}$ -level, typically 2.7 V.
- **Pre charge mode:** After qualification mode the PMU will enter the pre charge mode. A low charge current is used. Normally the battery is charged until the battery level is higher than V_{LOWBAT} and the fast charge mode will be activated.
- **Fast charge mode (CC/CV):** The battery will be charged with I_{CC} charging rate until the CV condition, $V_{BAT} > V_{MAX}$, is reached. CV mode will stop after the end-of-charge condition is reached (I_{MIN} or t_{MAX}).

5. Li-Ion battery charging topologies

There are several different battery technologies available in the market. This application note highlights the battery chargers, that are using external pass elements. You can differ between two main paths:

- Bipolar Junction Transistor (BJT) as pass element
 - BJT as current regulator
 - BJT as current regulator + MOSFET as control switch (load switch)
- MOSFET as pass element
 - Single MOSFET-Schottky diode module
 - Double MOSFET in back-to-back configuration

Often PMU with external bypass transistor are capable of driving a MOSFET. As an alternative a lower cost bipolar transistor can be used. NXP Semiconductors low V_{CEsat} Breakthrough In Small Signal (BISS) transistor perform the same function as a MOSFET at a lower cost, as an advantage there is no need for a blocking diode.

So a MOSFET-Schottky diode module or a double MOSFET can be replaced by a low V_{CEsat} BISS transistor and a resistor, if the PMU is capable of direct biasing the low V_{CEsat} BISS transistor.

5.1 Low V_{CEsat} BISS transistors as pass element

The Bipolar Junction Transistor (BJT) is a current-driven device, compared to the MOSFET which is a voltage-driven device. When designers want to use a BJT, as replacement of the MOSFET, they have to understand the current limitations of the PMU.

To ensure the low V_{CEsat} BISS transistor goes into saturation, the control pin of the PMU must be able to supply the base current (I_B), otherwise an additional control transistor would be required.

For example:

- Charging current 1000 mA
- Worst case current gain (h_{FE}) of 100

The control pin must be able to provide 10 mA for the low V_{CEsat} BISS transistor.

Low V_{CEsat} BISS transistors can be used in saturation mode and in linear mode. Both modes will be shown in the next two chapters.

5.1.1 BJT as current regulator

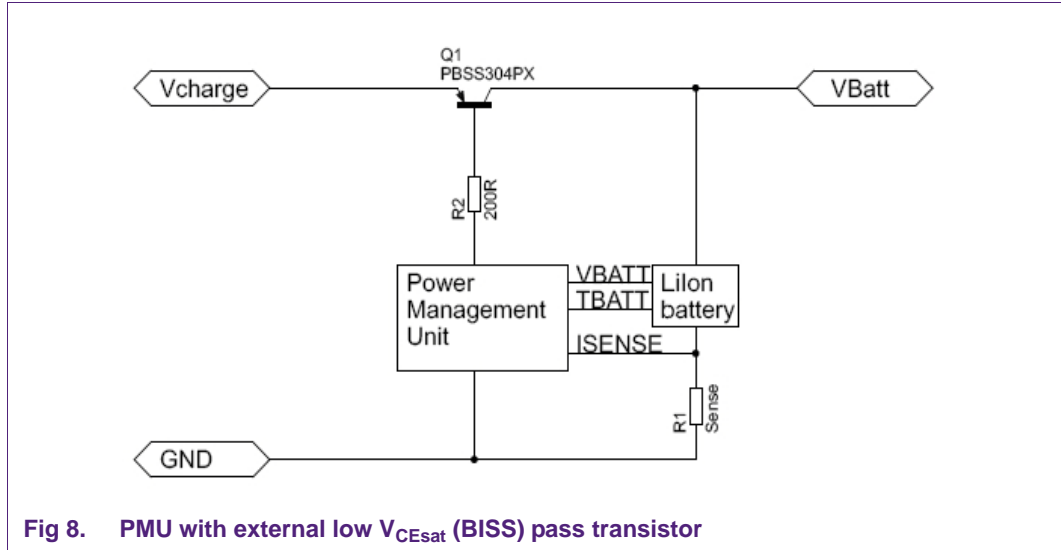

Fig 8. PMU with external low V_{CESat} (BISS) pass transistor

In switched current sources the low V_{CESat} transistor is used in saturation mode, the minimum gain should be taken into account, at 1 A the gain of the PBSS304PX is 200. Therefore a minimum base current of 5 mA is needed, to ensure we will set the base current to 10 mA. The additional resistor R2 should limit the maximum current of the drive stage.

(2)

$$P_{tot} = P_T + P_R$$

(3)

$$P_{tot} = (I_C \times V_{CESat}) + (I_B^2 \times R)$$

(4)

$$P_{tot} = (1A \times 80mV) + (10mA^2 \times 200\Omega) = 100mW$$

In linear mode the power dissipation of the low V_{CESat} BISS transistor increases due to higher voltage drops across the collector-emitter junction. In this case the PMU has to provide lower base currents compared to the switched mode. If the battery has to be charged via the USB interface the maximum supply voltage is 5.25 V. In worst case the minimum allowed battery voltage is 3.6 V, depends on the battery supplier specifications, for fast charge-mode.

(5)

$$P_{tot} = (1A \times 1,65V) = (1,65W)$$

Therefore a package must be chosen that fits mechanically in the application and the charging current must be adopted to the thermal capability of the transistor package.

5.1.2 BJT - MOSFET as load switch

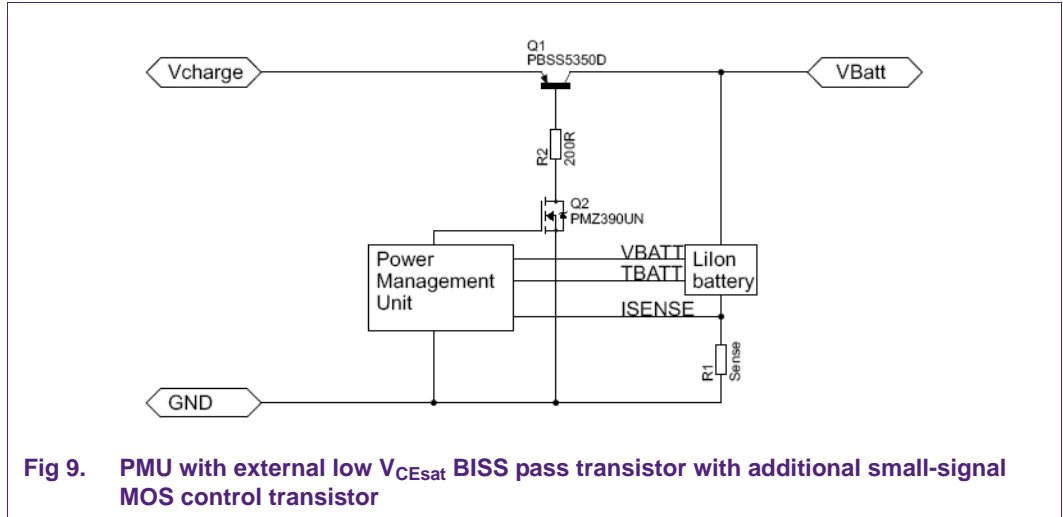

Fig 9. PMU with external low V_{CESat} BISS pass transistor with additional small-signal MOS control transistor

(6)

$$P_{tot} = P_T + P_R + P_M$$

(7)

$$P_{tot} = (I_C \times V_{CESat}) + (I_B^2 \times R) + (I_B^2 \times R_{DSon})$$

(8)

$$P_{tot} = (1A \times 80mV) + (10mA^2 \times 200\Omega) + (10mA^2 \times 390m\Omega) = (100,04mW)$$

5.2 MOSFETs as pass elements

Due to the fact that MOSFETs are voltage-driven, most PMUs will drive the MOSFET in a switched-mode. In addition to a MOSFET there is a need for a blocking diode in series connection to the MOSFET, because the body diode of each MOSFET conducts in reverse mode to prevent any reverse current from the battery.

5.2.1 MOSFET-Schottky diode module solution

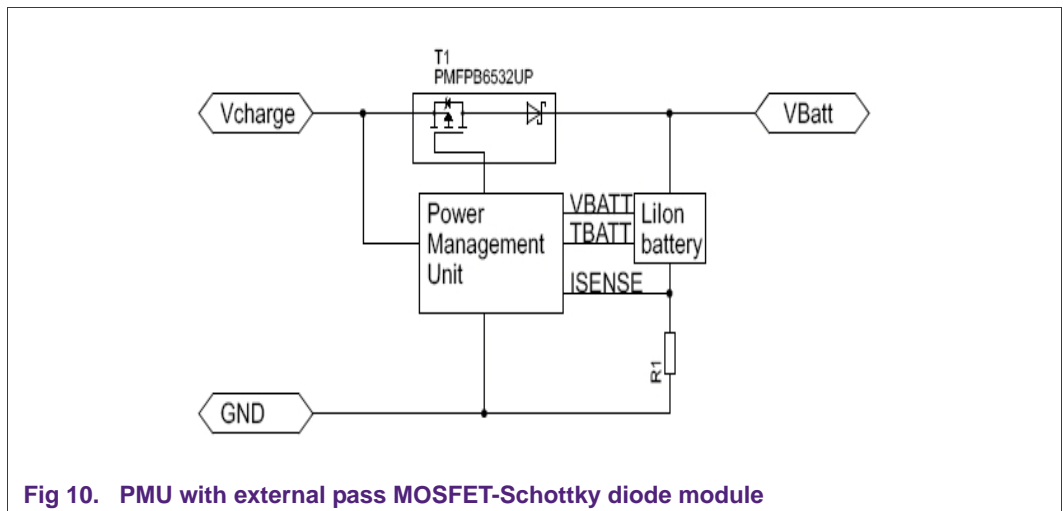

Fig 10. PMU with external pass MOSFET-Schottky diode module

The typical power dissipation through the MOSFET-Schottky diode module can be calculated as follows:

(9)

$$P_{tot} = P_T + P_D$$

(10)

$$P_{tot} = (I_D^2 \times R_{DSon}) + (I_D \times V_F)$$

(11)

$$P_{tot} = (1A^2 \times 65m\Omega) + (1A \times 325mV) = 390mW$$

5.2.2 Double FET solution

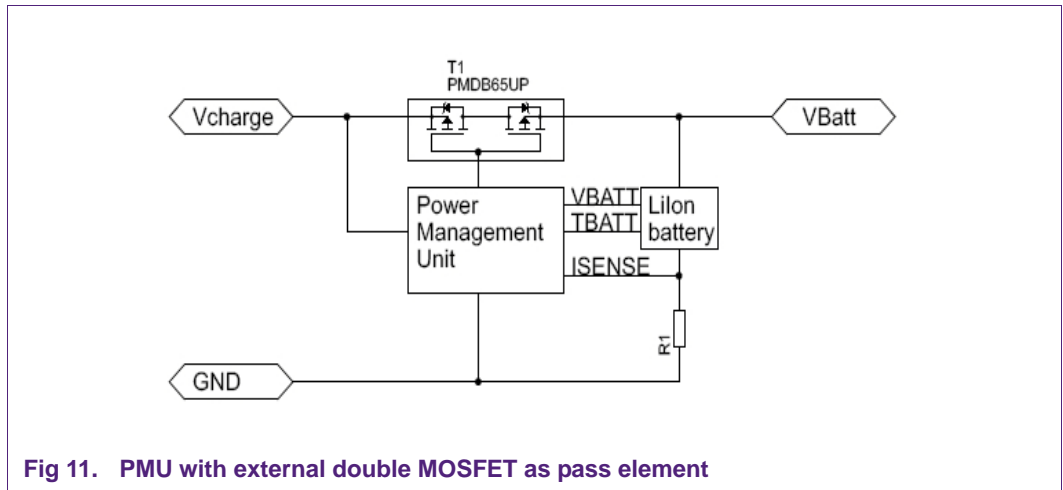

Fig 11. PMU with external double MOSFET as pass element

By connecting the MOSFET in this configuration, the Schottky diode has been eliminated. If both gates can be controlled independently, the PMU can control the charging current and also the discharging current if the USB port has to supply power. It is a superior solution compared to using a MOSFET-Schottky diode module, but it does cost more.

The typical power dissipation through the double MOSFET can be calculated as follows:

(12)

$$P_{tot} = 2 \times P_T$$

(13)

$$P_{tot} = 2 \times (I_D^2 \times R_{DSon})$$

(14)

$$P_{tot} = 2 \times (1A^2 \times 65m\Omega) = 130mW$$

6. Conclusion

NXP Semiconductors offers a wide variety of low V_{CEsat} BISS transistor, small signal Trench MOSFET and Maximum Efficiency General Application (MEGA) Schottky rectifier for Li-Ion battery charging applications in mobile device, as cellular phones, navigation systems and low power mobile computing.

Every solution has its own advantage and disadvantage, so every proposal is specific to customer's requirements and often other products can fit in a given customer's application. The usage of a low V_{CEsat} BISS transistor or a MOSFET / MOSFET-Schottky diode module depends initially on the technology of the PMU. But with an extra small-signal MOS, to control the base current, any MOSFET / MOSFET-Schottky diode module can be replaced by low V_{CEsat} BISS transistor.

NXP Semiconductors' low V_{CEsat} BISS is less sensitive to ESD damage compared to the MOSFET without internal ESD protection. It has a lower turn on voltage (typical $V_{BE} = 0.7$ V) compared to a MOSFET ($V_{GS} = 1.8$ V to 10 V). These advantages are very attractive for low voltage, battery-driven devices like cell phones. Because of the blocking voltages in both directions, the low V_{CEsat} BISS transistors eliminate the need for a blocking diode which is required when using a MOSFET, included in a MOSFET-Schottky diode module.

The IP428x family is designed for the tough requirements of reverse polarity and over-voltage protection. These products enable a simple and very effective protection concept for mobile device charger inputs. A further simplified solution with even higher integration density can be found in the IP4389CX4 which integrates a fast reacting fuse.

7. Appendix

Table 3. Transistor product portfolio

Name	Description	Dimension [mm]	Package	Release
PBSS304PD	PNP low V_{CEsat} , $V_{CEO} = 80$ V, $I_C = 3$ A	2.9 x 1.5 x 1.0	SOT457	Released
PBSS304PX	PNP low V_{CEsat} , $V_{CEO} = 60$ V, $I_C = 4.2$ A	4.5 x 2.5 x 1.5	SOT89	Released
PMV65XP	P-ch. MOSFET-Schottky, $V_{DS} = 20$ V, $R_{DSon} = 65$ m Ω	2.9 x 1.3 x 1.0	SOT23	Released
PMN50XP	P-ch. MOSFET-Schottky, $V_{DS} = 20$ V, $R_{DSon} = 48$ m Ω	2.9 x 1.5 x 1.0	SOT457	Released
PMZ390UN	N-ch. MOSFET, $V_{DS} = 30$ V, $R_{DSon} = 390$ m Ω	1.0 x 0.6 x 0.5	SOT883	Released
PMFPB6545UP	P-ch. MOSFET-Schottky, $V_{DS} = 20$ V, $R_{DSon} = 65$ m Ω , $V_F = 455$ mV	2.0 x 2.0 x 0.65	SOT1118	Released
PMFPB6532UP	P-ch. MOSFET-Schottky, $V_{DS} = 20$ V, $R_{DSon} = 65$ m Ω , $V_F = 325$ mV	2.0 x 2.0 x 0.65	SOT1118	Released
PBSS5330X	PNP low V_{CEsat} , $V_{CEO} = 30$ V, $I_C = 3$ A	4.5 x 2.5 x 1.5	SOT89	Released
PBSS5330PA	PNP low V_{CEsat} , $V_{CEO} = 30$ V, $I_C = 3$ A	2.0 x 2.0 x 0.65	SOT1061	Released
PMR400UN	N-ch. MOSFET, $V_{DS} = 30$ V, $R_{DSon} = 400$ m Ω	1.6 x 0.8 x 0.77	SOT416	Released
PMDPB70XP	Double P-ch. MOSFET, $V_{DS} = 30$ V, $R_{DSon} = 70$ m Ω	2.0 x 2.0 x 0.65	SOT1118	Dec. 2011
PBSM5240PF	PNP low V_{CEsat} , $V_{CEO} = 40$ V, $I_C = 2$ A N-ch. MOSFET, $V_{DS} = 30$ V, $R_{DSon} = 400$ m Ω	2.0 x 2.0 x 0.65	SOT1118	Released
PMDPB65UP	Double P-ch. MOSFET, $V_{DS} = 20$ V, $R_{DSon} = 65$ m Ω	2.0 x 2.0 x 0.65	SOT1118	Released

Table 4. ESD protection product portfolio

Name	Description	Dimension [mm]	Package	Release
IP4221CZ6-S	$V_{RWM} = 5.5 \text{ V}$, $C_d = 1.0 \text{ pF}$, $V_{ESD(max)} = 8 \text{ kV}$, quad	1.45 x 1.0 x 0.5	SOT886	Released
IP4221CZ6-XS	$V_{RWM} = 5.5 \text{ V}$, $C_d = 1.0 \text{ pF}$, $V_{ESD(max)} = 8 \text{ kV}$, quad	1.0 x 1.0 x 0.5	SOT891	Released
IP4282CZ6	$V_{RWM} = 5.5 \text{ V}$, $C_d = 0.7 \text{ pF}$, $V_{ESD(max)} = 8 \text{ kV}$, dual	1.45 x 1.0 x 0.5	SOT886	Released
IP4284CZ10-TB	$V_{RWM} = 5.5 \text{ V}$, $C_{ch} = 0.5 \text{ pF}$, $V_{ESD(max)} = 8 \text{ kV}$, quad	2.5 x 1.0 x 0.5	SOT1059	Released
IP4059CX5	$V_{RWM} = 5.5 \text{ V}$, $C_d = 3.0 \text{ pF}$, $V_{ESD(max)} = 15 \text{ kV}$, triple	0.96 x 1.34 x 0.65	WLCSP5	Released
IP4359CX4/LF	$V_{RWM} = 5.5 \text{ V}$, $C_d = 1.3 \text{ pF}$, $V_{ESD(max)} = 15 \text{ kV}$, dual	0.91 x 0.91 x 0.65	WLCSP4	Released
PESD5V0F1BL	$V_{RWM} = 5.5 \text{ V}$, $C_d = 0.4 \text{ pF}$, $V_{ESD(max)} = 10 \text{ kV}$, single	1.0 x 0.6 x 0.5	SOD882	Released
PESD5V0X1BL	$V_{RWM} = 5 \text{ V}$, $C_d = 0.9 \text{ pF}$, $V_{ESD(max)} = 9 \text{ kV}$, single	1.0 x 0.6 x 0.5	SOD882	Released
PRTR5V0U2F	$V_{RWM} = 5 \text{ V}$, $C_L = 1.0 \text{ pF}$, $V_{ESD(max)} = 8 \text{ kV}$, dual	1.45 x 1.0 x 0.5	SOT886	Released

Table 5. Reverse polarity and overvoltage protection product portfolio

Name	Description	Dimension [mm]	Package	Release
IP4085CX4/LF	$V_{RWM} = 14 \text{ V}$, $I_{PP(min)} = 60 \text{ A}$, $P_{tot} = 1 \text{ W}$, $V_{ESD(max)} = 30 \text{ kV}$	0.91 x 0.91 x 0.65	WLCSP4	Released
IP4385CX4	$V_{RWM} = 5.5 \text{ V}$, $I_{PP(min)} = 33 \text{ A}$, $P_{tot} = 0.7 \text{ W}$, $V_{ESD(max)} = 30 \text{ kV}$	0.76 x 0.75 x 0.61	WLCSP4	Released
IP4386CX4	$V_{RWM} = 14 \text{ V}$, $I_{PP(min)} = 28 \text{ A}$, $P_{tot} = 0.7 \text{ W}$, $V_{ESD(max)} = 30 \text{ kV}$	0.76 x 0.75 x 0.61	WLCSP4	Released
IP4387CX4	$V_{RWM} = 8 \text{ V}$, $I_{PP(min)} = 33 \text{ A}$, $P_{tot} = 0.7 \text{ W}$, $V_{ESD(max)} = 30 \text{ kV}$	0.76 x 0.75 x 0.61	WLCSP4	Released
IP4389CX4	$V_{RWM} = 8 \text{ V}$, $I_{PP(min)} = 24 \text{ A}$, $P_{tot} = 0.7 \text{ W}$, $V_{ESD(max)} = 30 \text{ kV}$, $I_{fuse(M)} = 2 \text{ A}$, $t_{fuse(max)} = 100 \text{ ms}$	0.76 x 0.75 x 0.61	WLCSP4	Released

For further information, please visit the following web site:

www.nxp.com/applications/portable/cellular_phone_mms/index.html

8. References

- [1] “PCF50603 Application Note” — Charging a Li-Ion battery with PCF50603, Philips Semiconductors BL Power Management

9. Legal information

9.1 Definitions

Draft — The document is a draft version only. The content is still under internal review and subject to formal approval, which may result in modifications or additions. NXP Semiconductors does not give any representations or warranties as to the accuracy or completeness of information included herein and shall have no liability for the consequences of use of such information.

9.2 Disclaimers

Limited warranty and liability — Information in this document is believed to be accurate and reliable. However, NXP Semiconductors does not give any representations or warranties, expressed or implied, as to the accuracy or completeness of such information and shall have no liability for the consequences of use of such information.

In no event shall NXP Semiconductors be liable for any indirect, incidental, punitive, special or consequential damages (including - without limitation - lost profits, lost savings, business interruption, costs related to the removal or replacement of any products or rework charges) whether or not such damages are based on tort (including negligence), warranty, breach of contract or any other legal theory.

Notwithstanding any damages that customer might incur for any reason whatsoever, NXP Semiconductors' aggregate and cumulative liability towards customer for the products described herein shall be limited in accordance with the *Terms and conditions of commercial sale* of NXP Semiconductors.

Right to make changes — NXP Semiconductors reserves the right to make changes to information published in this document, including without limitation specifications and product descriptions, at any time and without notice. This document supersedes and replaces all information supplied prior to the publication hereof.

Suitability for use — NXP Semiconductors products are not designed, authorized or warranted to be suitable for use in life support, life-critical or safety-critical systems or equipment, nor in applications where failure or malfunction of an NXP Semiconductors product can reasonably be expected to result in personal injury, death or severe property or environmental damage. NXP Semiconductors accepts no liability for inclusion and/or use of NXP Semiconductors products in such equipment or applications and therefore such inclusion and/or use is at the customer's own risk.

Applications — Applications that are described herein for any of these products are for illustrative purposes only. NXP Semiconductors makes no representation or warranty that such applications will be suitable for the specified use without further testing or modification.

Customers are responsible for the design and operation of their applications and products using NXP Semiconductors products, and NXP Semiconductors accepts no liability for any assistance with applications or customer product

design. It is customer's sole responsibility to determine whether the NXP Semiconductors product is suitable and fit for the customer's applications and products planned, as well as for the planned application and use of customer's third party customer(s). Customers should provide appropriate design and operating safeguards to minimize the risks associated with their applications and products.

NXP Semiconductors does not accept any liability related to any default, damage, costs or problem which is based on any weakness or default in the customer's applications or products, or the application or use by customer's third party customer(s). Customer is responsible for doing all necessary testing for the customer's applications and products using NXP Semiconductors products in order to avoid a default of the applications and the products or of the application or use by customer's third party customer(s). NXP does not accept any liability in this respect.

Export control — This document as well as the item(s) described herein may be subject to export control regulations. Export might require a prior authorization from national authorities.

Evaluation products — This product is provided on an "as is" and "with all faults" basis for evaluation purposes only. NXP Semiconductors, its affiliates and their suppliers expressly disclaim all warranties, whether express, implied or statutory, including but not limited to the implied warranties of non-infringement, merchantability and fitness for a particular purpose. The entire risk as to the quality, or arising out of the use or performance, of this product remains with customer.

In no event shall NXP Semiconductors, its affiliates or their suppliers be liable to customer for any special, indirect, consequential, punitive or incidental damages (including without limitation damages for loss of business, business interruption, loss of use, loss of data or information, and the like) arising out of the use of or inability to use the product, whether or not based on tort (including negligence), strict liability, breach of contract, breach of warranty or any other theory, even if advised of the possibility of such damages.

Notwithstanding any damages that customer might incur for any reason whatsoever (including without limitation, all damages referenced above and all direct or general damages), the entire liability of NXP Semiconductors, its affiliates and their suppliers and customer's exclusive remedy for all of the foregoing shall be limited to actual damages incurred by customer based on reasonable reliance up to the greater of the amount actually paid by customer for the product or five dollars (US\$5.00). The foregoing limitations, exclusions and disclaimers shall apply to the maximum extent permitted by applicable law, even if any remedy fails of its essential purpose.

9.3 Trademarks

Notice: All referenced brands, product names, service names and trademarks are the property of their respective owners.

10. Contents

1	Introduction	3
2	Battery charging via USB interface	3
2.1	Chinese battery charging standard (YDT1591-2006)	3
2.1.1	PC USB port	3
2.2	Micro-USB connector in smart phone	3
2.3	V _{BUS} electrical characteristics	4
2.4	General USB requirements	4
3	Charger interface and USB protection	5
3.1	Reverse polarity protection	5
3.2	Overvoltage protection	6
3.3	USB data ESD protection	6
3.3.1	Rail-to-rail concept for low capacitance ESD protection	6
3.3.2	USB data line ESD protection with rail-to-rail devices	7
3.4	Protection devices	8
4	Li-Ion batteries	8
5	Li-Ion battery charging topologies	10
5.1	Low V _{CEsat} BISS transistors as pass element	10
5.1.1	BJT as current regulator	11
5.1.2	BJT - MOSFET as load switch	12
5.2	MOSFETs as pass elements	12
5.2.1	MOSFET-Schottky diode module solution ...	12
5.2.2	Double FET solution	13
6	Conclusion	14
7	Appendix	14
8	References	15
9	Legal information	16
9.1	Definitions	16
9.2	Disclaimers	16
9.3	Trademarks	16
10	Contents	17

Please be aware that important notices concerning this document and the product(s) described herein, have been included in section 'Legal information'.

© NXP B.V. 2011.

All rights reserved.

For more information, please visit: <http://www.nxp.com>

For sales office addresses, please send an email to: salesaddresses@nxp.com

Date of release: 23 June 2011

Document identifier: AN10910