

DC/DC Converter 9 to 36Vdc or 18 to 75Vdc Input

3.3 to 15Vdc Single Outputs and ± 5 Vdc to ± 15 Vdc Dual Outputs 15W Output Power



E188913

Complete THN 15-WI datasheet can be downloaded at:

<http://www.tracopower.com/products/thn15wi.pdf>

General Description

THN 15-WI single output DC/DC converters provide up to 15 watts of output power in an industry standard package and footprint. These units are specifically designed to meet the power needs of low profile. All models feature with 4:1 ultra wide input voltage of 9-36 Vdc and 18-75 Vdc ,comprehensively protected against over-current, over-voltage and input under-voltage protection conditions, and adjustable output voltage.

Table of contents

Absolute Maximum Rating	P2	Short Circuitry Protection	P40
Output Specification	P2	Thermal Consideration	P40
Input Specification	P3	Heat Sink Consideration	P40
General Specification	P4	Remote ON/OFF Control	P41
Characteristic Curves	P5 – P32	Mechanical Data	P42
Testing Configurations	P33	Recommended Pad Layout	P43
EMC Consideration	P34 – P38	Soldering and Reflow Considerations	P43
Input Source Impedance	P38	Packaging Information	P44
Output Over Current Protection	P38	Part Number Structure	P44
Output Over Voltage Protection	P38	Safety and Installation Instruction	P45
Output Voltage Adjustment	P39	MTBF and Reliability	P45

Features

- Single output current up to 4A
- 15 watts output power
- 4:1 ultra wide input voltage range of 9-36 and 18-75VDC
- Industry standard pin-out TEN 15 series compatible
- High efficiency up to 87%
- Low profile: 25.4 x 25.4 x 9.9mm (1.0 x 1.0 x 0.39 inch)
- Fixed switching frequency
- RoHS directive compliant
- No minimum load
- Input to output isolation: 1500Vdc, min
- Input to output isolation (BASIC INSULATION)
- Input under-voltage protection
- Output over-voltage protection
- Over-current protection, auto-recovery
- Output short circuit protection
- Remote ON/OFF control
- Adjustable output voltage

Options

- Heat sinks available for extended operation temperature

Applications

- Wireless Network
- Telecom/Datacom
- Industry Control System
- Measurement
- Semiconductor Equipment

Absolute Maximum Rating				
Parameter	Model	Min	Max	Unit
Input Voltage	THN 15-24xxWI THN 15-48xxWI		36	Vdc
			75	
Transient (100mS)	THN 15-24xxWI THN 15-48xxWI		50	
			100	
Input Voltage Variation (complies with ETS300 132 part 4.4)	All		5	V/mS
Operating Ambient Temperature (with derating)	All	-40	85	°C
Storage Temperature	All	-55	125	°C

Output Specification					
Parameter	Model	Min	Typ	Max	Unit
Output Voltage Range ($V_{in\,nom}$; Full Load; $T_A = 25^\circ\text{C}$)	THN 15-xx10WI	3.267	3.3	3.333	V_{DC}
	THN 15-xx11WI	4.95	5	5.05	
	THN 15-xx12WI	11.88	12	12.12	
	THN 15-xx13WI	14.85	15	15.15	
	THN 15-xx21WI	± 4.95	± 5	± 5.05	
	THN 15-xx22WI	± 11.88	± 12	± 12.12	
	THN 15-xx23WI	± 14.85	± 15	± 15.15	
Voltage Adjustability (See Page 25)	All	-10		+10	%
Output Regulation	All	-0.2		+0.2	%
				-0.2	
Output Ripple & Noise(See Page 21) Peak-to-Peak (20MHz bandwidth) (Measured with a 1 μF M/C and a 10 μF T/C)	THN 15-xx10WI		75		mV_{Pk-Pk}
	All other		100		
Temperature Coefficient	All	-0.02		+0.02	%/°C
Output Voltage Overshoot ($V_{in\,min}$ to $V_{in\,max}$; Full Load; $T_A = 25^\circ\text{C}$)	All		0	3	% V_{out}
Dynamic Load Response ($V_{in\,nom}$; $T_A = 25^\circ\text{C}$) Load step change from 75% to 100% or 100 to 75% of Full Load Peak Deviation Setting Time ($V_{OUT} < 10\%$ peak deviation)	All		300		mV μS
	All		250		
Output Current	THN 15-xx10WI	0		4000	mA
	THN 15-xx11WI	0		3000	
	THN 15-xx12WI	0		1300	
	THN 15-xx13WI	0		1000	
	THN 15-xx21WI	0		± 1500	
	THN 15-xx22WI	0		± 625	
	THN 15-xx23WI	0		± 500	
Output Over Voltage Protection (Voltage Clamped)	THN 15-xx10WI	3.7		5.4	Vdc
	THN 15-xx11WI	5.6		7.0	
	THN 15-xx12WI	13.5		19.6	
	THN 15-xx13WI	16.8		20.5	
	THN 15-xx21WI	5.6		7.0	
	THN 15-xx22WI	13.5		19.6	
	THN 15-xx23WI	16.8		20.5	
Output Over Current Protection	All		150		% FL.
Output Short Circuit Protection	All	Hiccup, automatics recovery			

Input Specification					
Parameter	Model	Min	Typ	Max	Unit
Operating Input Voltage	THN 15-24xxWI	9	24	36	Vdc
	THN 15-48xxWI	18	48	75	
Input Current (Maximum value at $V_{in,nom}$; Full Load)	THN 15-2410WI			688	mA
	THN 15-2411WI			782	
	THN 15-2412WI			803	
	THN 15-2413WI			772	
	THN 15-2421WI			772	
	THN 15-2422WI			753	
	THN 15-2423WI			744	
	THN 15-4810WI			336	
	THN 15-4811WI			382	
	THN 15-4812WI			392	
	THN 15-4813WI			377	
	THN 15-4821WI			386	
	THN 15-4822WI			382	
THN 15-4823WI			377		
Input Standby Current (Typical value at $V_{in,nom}$; No Load)	THN 15-2410WI		50		mA
	THN 15-2411WI		50		
	THN 15-2412WI		20		
	THN 15-2413WI		20		
	THN 15-2421WI		20		
	THN 15-2422WI		25		
	THN 15-2423WI		25		
	THN 15-4810WI		40		
	THN 15-4811WI		40		
	THN 15-4812WI		15		
	THN 15-4813WI		15		
	THN 15-4821WI		15		
	THN 15-4822WI		15		
THN 15-4823WI		20			
Under Voltage Lockout Turn-on Threshold	THN 15-24xxWI			9	Vdc
	THN 15-48xxWI			18	
Under Voltage Lockout Turn-off Threshold	THN 15-24xxWI		8		Vdc
	THN 15-48xxWI		16		
Input Reflected Ripple Current (See Page 21) (5 to 20MHz, 12 μ H source impedance)	All		30		mA_{PK-PK}
Start Up Time ($V_{in,nom}$ and constant resistive load)					mS
	Power up	All	30		
	Remote ON/OFF		30		
Remote ON/OFF Control (See Page 27) (The ON/OFF pin voltage is referenced to $-V_{in}$)					Vdc
	Positive Logic DC-DC ON(Open)	All	3	15	
DC-DC OFF(Short)		0		1.2	
Remote Off Input Current	All		2.5		mA
Input Current of Remote Control Pin	All	-0.5		1.0	mA

General Specification					
Parameter	Model	Min	Typ	Max	Unit
Efficiency (See Page 21) ($V_{in, nom}$; Full Load; $T_A = 25^\circ\text{C}$)	THN 15-2410WI		86		%
	THN 15-2411WI		84		
	THN 15-2412WI		86		
	THN 15-2413WI		85		
	THN 15-2421WI		85		
	THN 15-2422WI		87		
	THN 15-2423WI		88		
	THN 15-4810WI		86		
	THN 15-4811WI		86		
	THN 15-4812WI		87		
	THN 15-4813WI		87		
	THN 15-4821WI		85		
	THN 15-4822WI		86		
	THN 15-4823WI		87		
Isolation Voltage (Basic Insulation) Input to Output (1 minute) Input/Output to Case (1 minute)	All	1600 1000			Vdc
Isolation Resistance	All	1			G Ω
Isolation Capacitance	All			1000	pF
Switching Frequency	All		400		KHz
Weight	All		15		g
MTBF (See Page 31) Bellcore TR-NWT-000332, $T_C = 40^\circ\text{C}$ MIL-STD-217F	All		1'330'000 563'000		hours

Characteristic Curves

All test conditions are at 25°C. The figures are identical for THN 15-2410WI

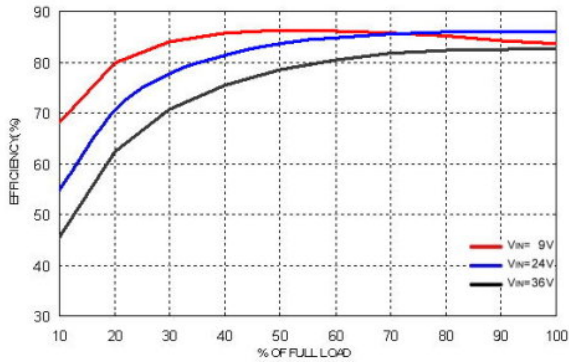

Efficiency versus Output Current

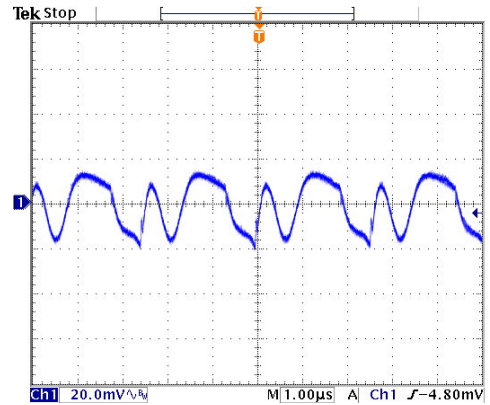

Typical Output Ripple and Noise.

$V_{in,nom}$; Full Load

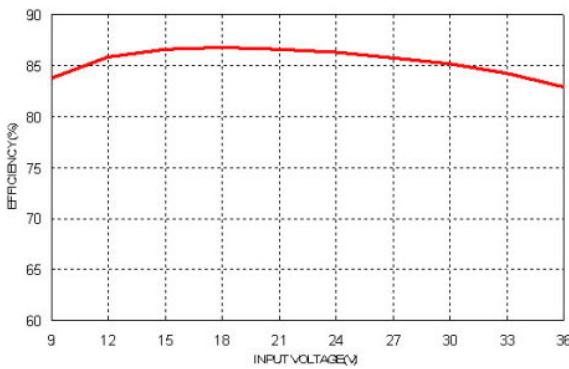

Efficiency versus Input Voltage. Full Load

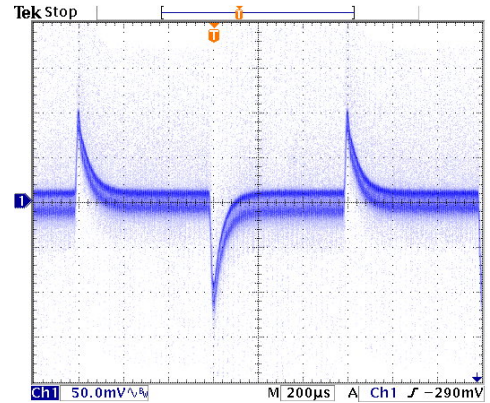

Transient Response to Dynamic Load Change from 100% to 75% to 100% of Full Load; $V_{in,nom}$

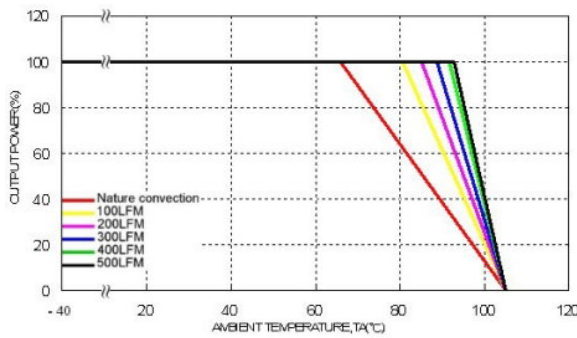

Derating Output Current versus Ambient Temperature and Airflow $V_{in} = V_{in,nom}$

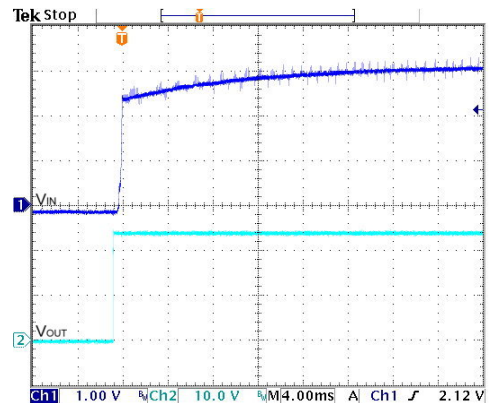

Typical Input Start-Up and Output Rise Characteristic

$V_{in,nom}$; Full Load

Characteristic Curves (Continued)

All test conditions are at 25°C. The figures are identical for THN 15-2410WI

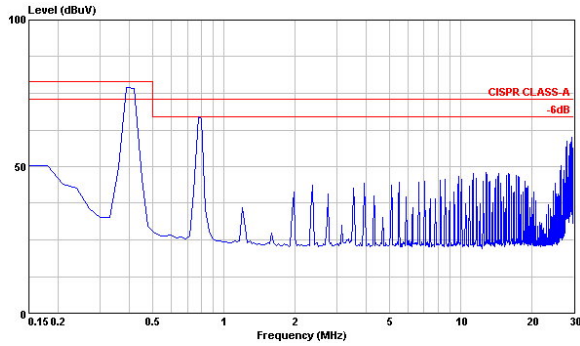

Conduction Emission of EN55022 Class A
 $V_{in,nom}$; Full Load

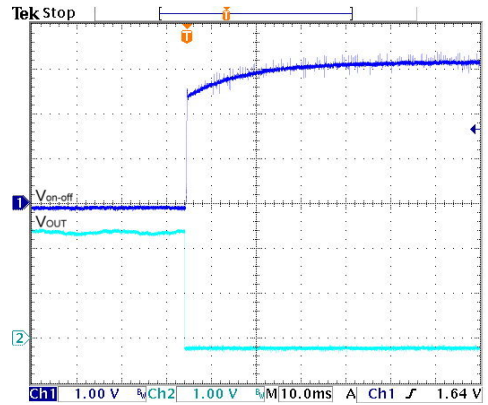

Using ON/OFF Voltage Start-Up and V_{out} Rise Characteristic
 $V_{in,nom}$; Full Load

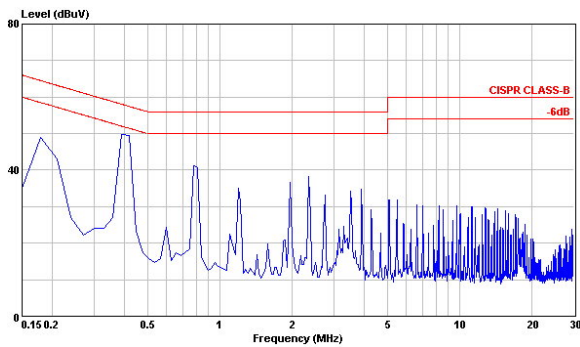

Conduction Emission of EN55022 Class B
 $V_{in,nom}$; Full Load

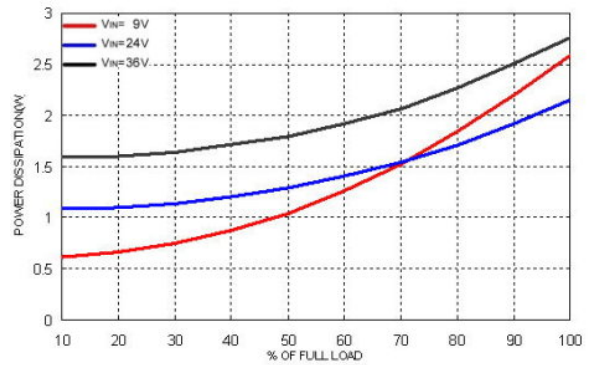

Power Dissipation versus Output Current

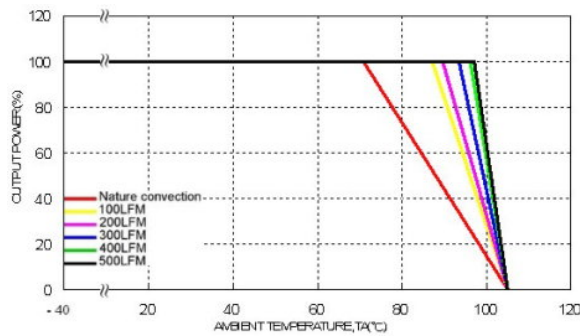

Derating Output Current Versus Ambient Temperature with Heat-Sink and Airflow, $V_{in} = V_{in,nom}$

Characteristic Curves (Continued)

All test conditions are at 25°C. The figures are identical for THN 15-2411WI

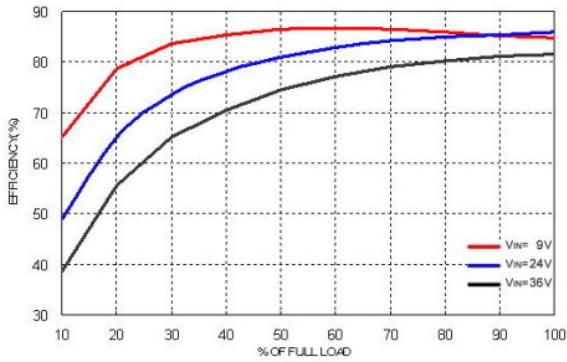

Efficiency versus Output Current

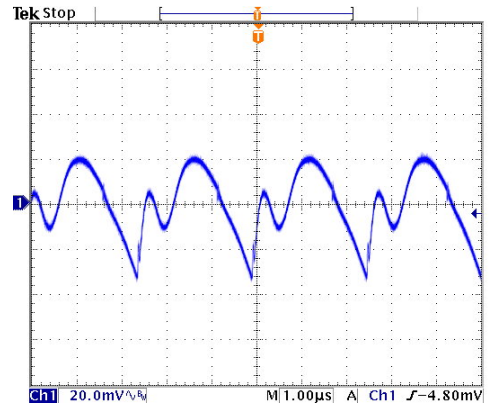

Typical Output Ripple and Noise.

$V_{in,nom}$; Full Load

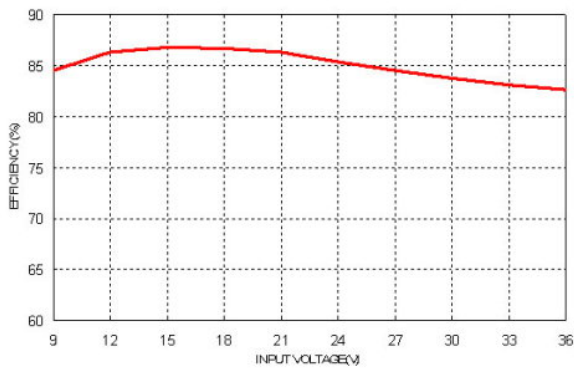

Efficiency versus Input Voltage. Full Load

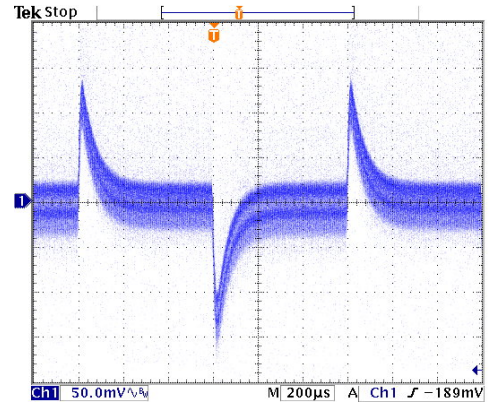

Transient Response to Dynamic Load Change from 100% to 75% to 100% of Full Load ; $V_{in,nom}$

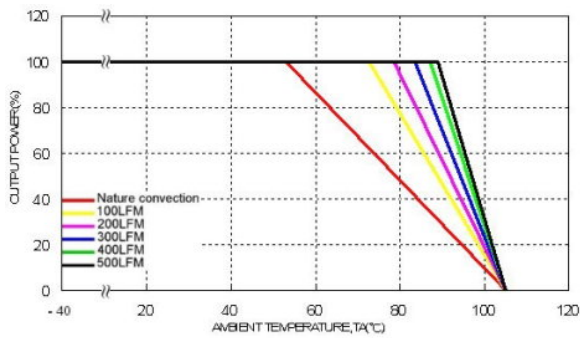

Derating Output Current versus Ambient Temperature and Airflow $V_{in} = V_{in,nom}$

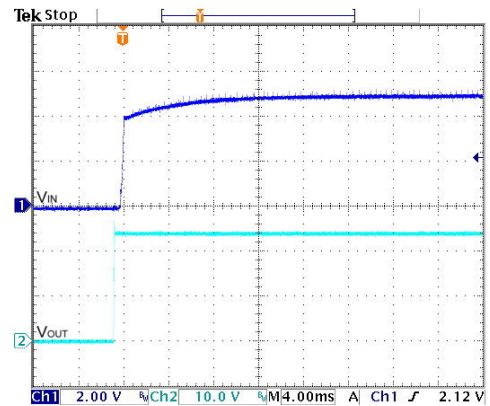

Typical Input Start-Up and Output Rise Characteristic $V_{in,nom}$; Full Load

Characteristic Curves (Continued)

All test conditions are at 25°C. The figures are identical for THN 15-2411WI

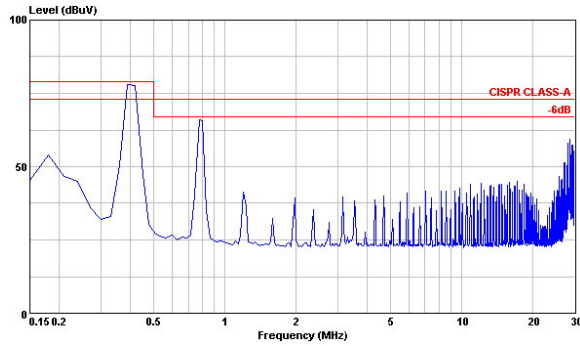

Conduction Emission of EN55022 Class A
 $V_{in, nom}$; Full Load

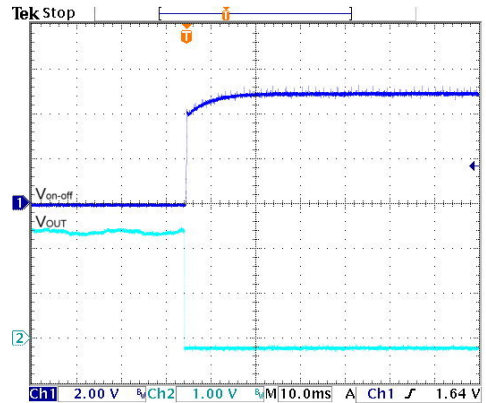

Using ON/OFF Voltage Start-Up and V_{out} Rise Characteristic
 $V_{in, nom}$; Full Load

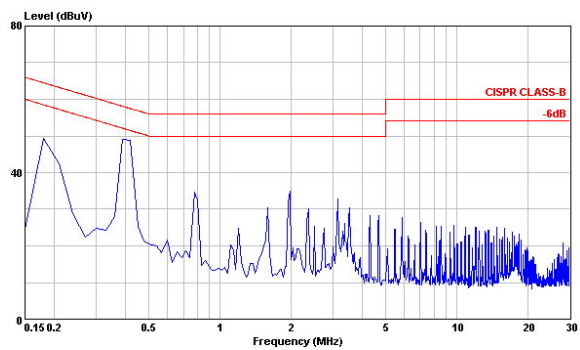

Conduction Emission of EN55022 Class B
 $V_{in, nom}$; Full Load

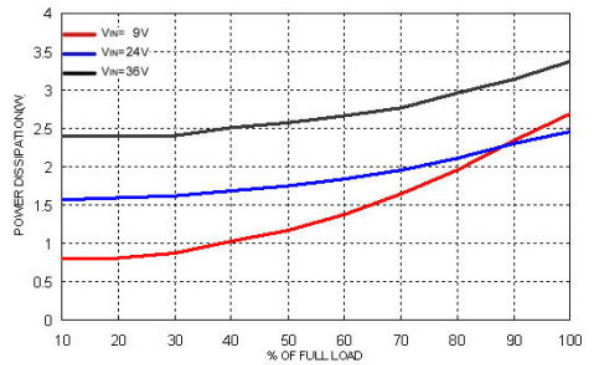

Power Dissipation versus Output Current

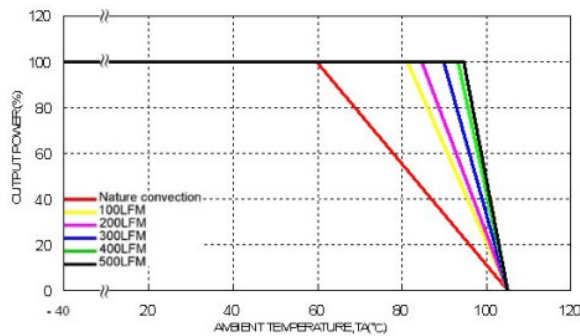

Derating Output Current Versus Ambient Temperature with Heat-Sink and Airflow, $V_{in} = V_{in, nom}$

Characteristic Curves (Continued)

All test conditions are at 25°C. The figures are identical for THN 15-2412WI

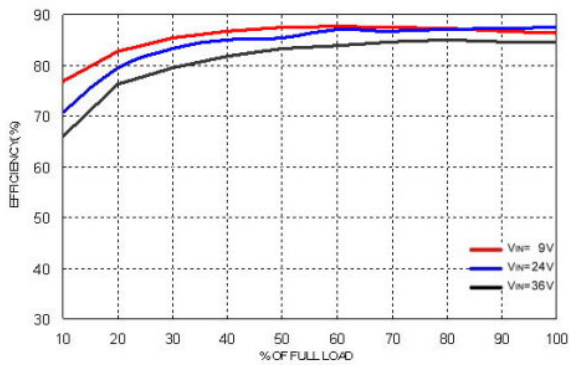

Efficiency versus Output Current

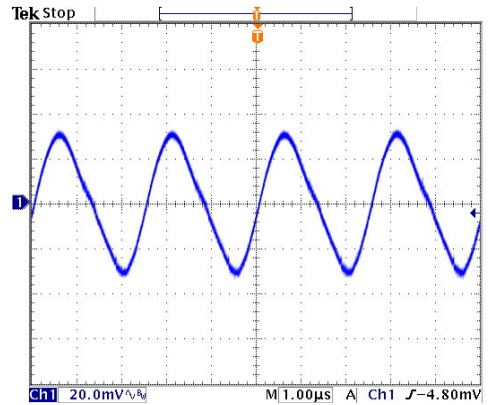

Typical Output Ripple and Noise.

$V_{in,nom}$; Full Load

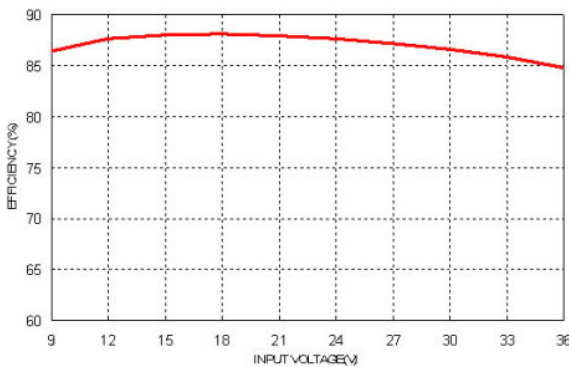

Efficiency versus Input Voltage. Full Load

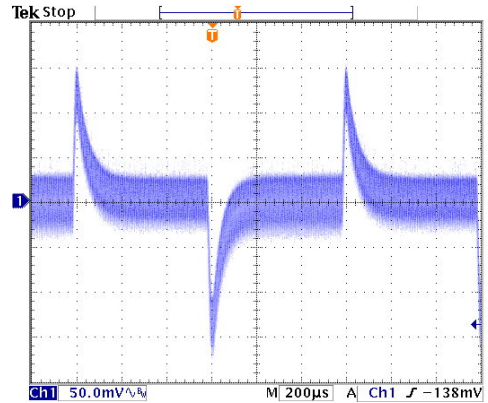

Transient Response to Dynamic Load Change from 100% to 75% to 100% of Full Load ; $V_{in,nom}$

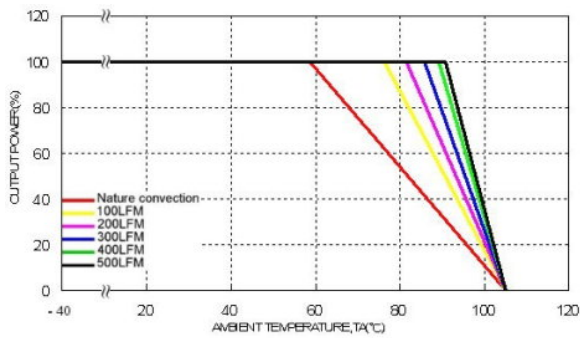

Derating Output Current versus Ambient Temperature and Airflow $V_{in} = V_{in,nom}$

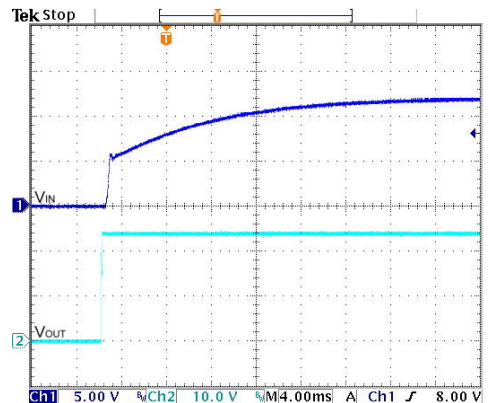

Typical Input Start-Up and Output Rise Characteristic

$V_{in,nom}$; Full Load

Characteristic Curves (Continued)

All test conditions are at 25°C. The figures are identical for THN 15-2412WI

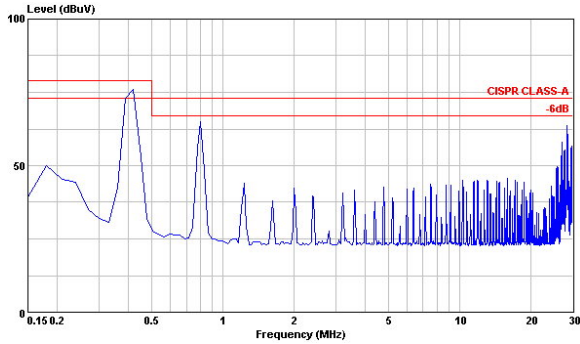

Conduction Emission of EN55022 Class A
 $V_{in, nom}$; Full Load

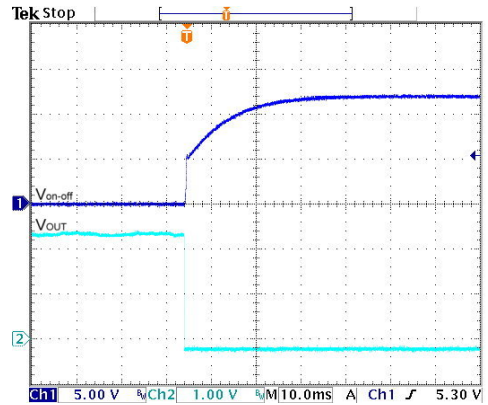

Using ON/OFF Voltage Start-Up and V_{out} Rise Characteristic
 $V_{in, nom}$; Full Load

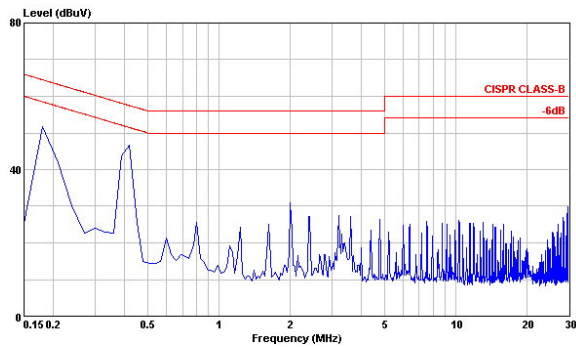

Conduction Emission of EN55022 Class B
 $V_{in, nom}$; Full Load

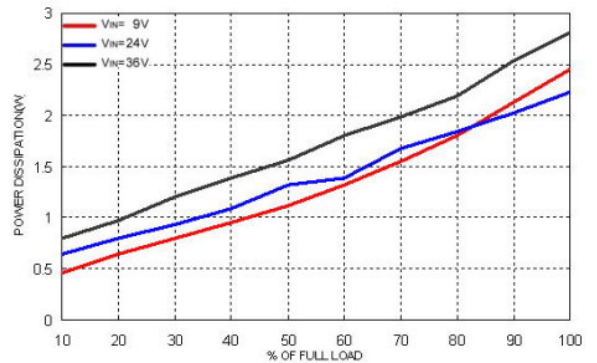

Power Dissipation versus Output Current

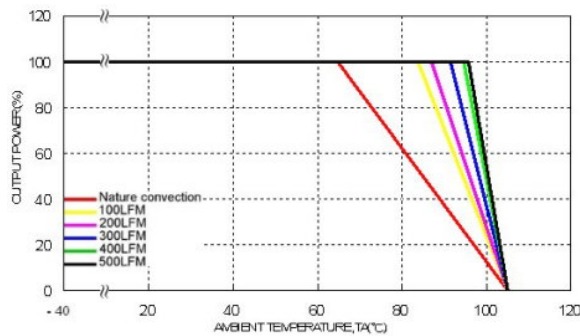

Derating Output Current Versus Ambient Temperature with Heat-Sink and Airflow, $V_{in} = V_{in, nom}$

Characteristic Curves (Continued)

All test conditions are at 25°C. The figures are identical for THN 15-2413WI

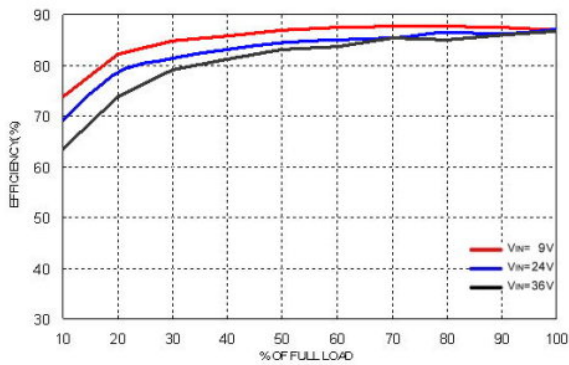

Efficiency versus Output Current

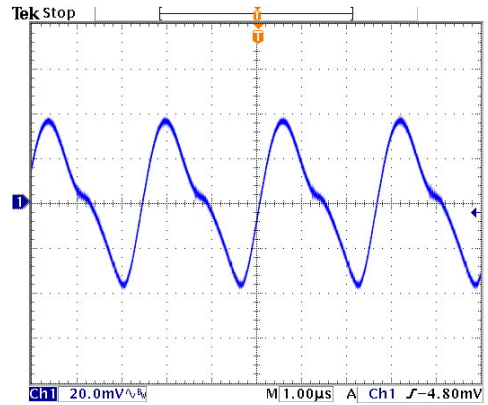

Typical Output Ripple and Noise.

$V_{in,nom}$; Full Load

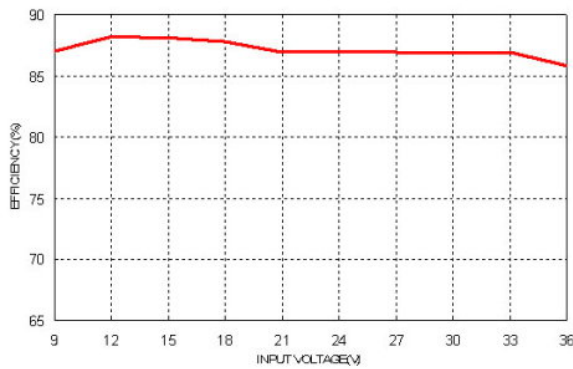

Efficiency versus Input Voltage. Full Load

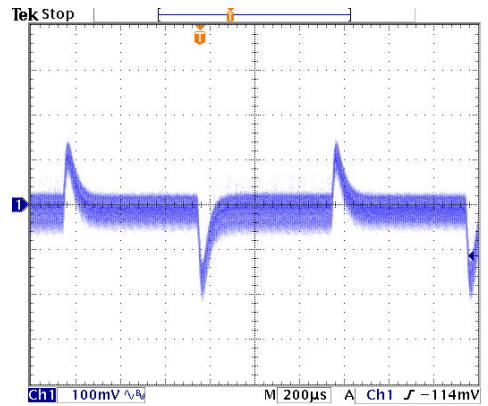

Transient Response to Dynamic Load Change from 100% to 75% to 100% of Full Load ; $V_{in,nom}$

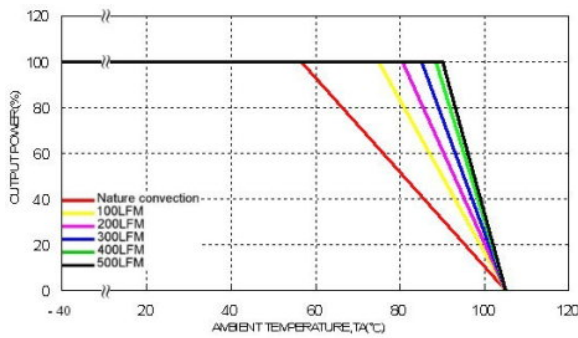

Derating Output Current versus Ambient Temperature and Airflow $V_{in} = V_{in,nom}$

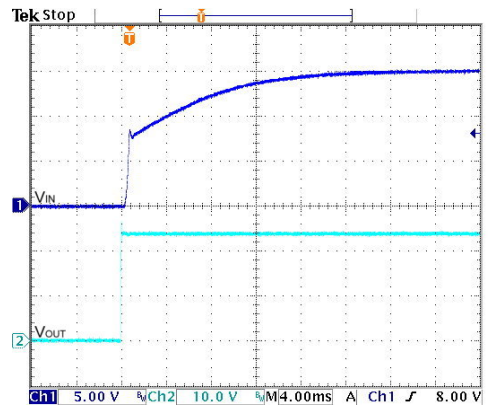

Typical Input Start-Up and Output Rise Characteristic $V_{in,nom}$; Full Load

Characteristic Curves (Continued)

All test conditions are at 25°C. The figures are identical for THN 15-2413WI

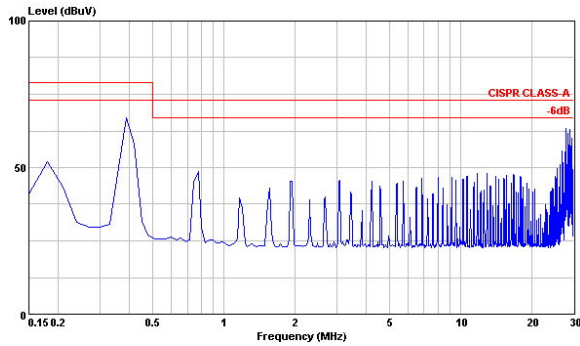

Conduction Emission of EN55022 Class A
 $V_{in,nom}$; Full Load

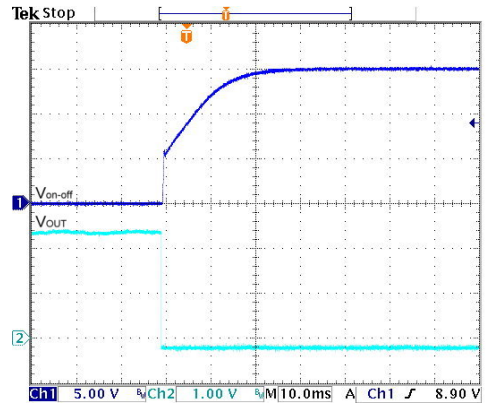

Using ON/OFF Voltage Start-Up and V_{out} Rise Characteristic
 $V_{in,nom}$; Full Load

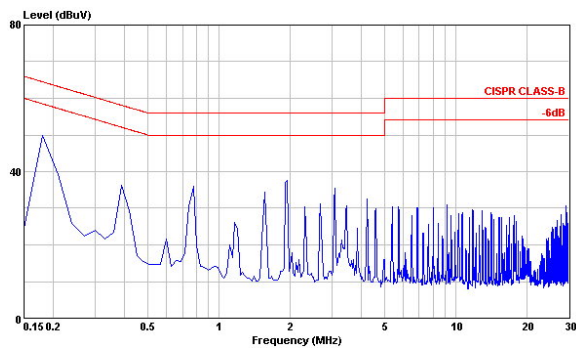

Conduction Emission of EN55022 Class B
 $V_{in,nom}$; Full Load

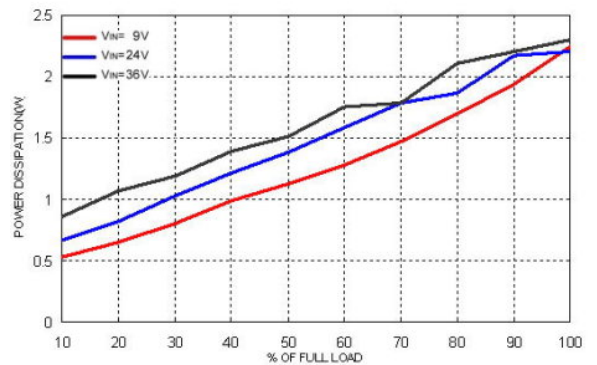

Power Dissipation versus Output Current

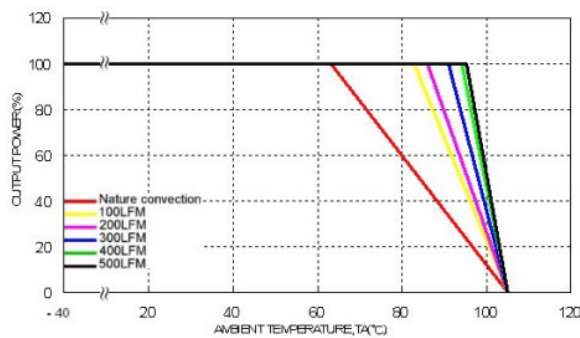

Derating Output Current Versus Ambient Temperature with Heat-Sink and Airflow, $V_{in} = V_{in,nom}$

Characteristic Curves

All test conditions are at 25°C. The figures are identical for THN 15-2421WI

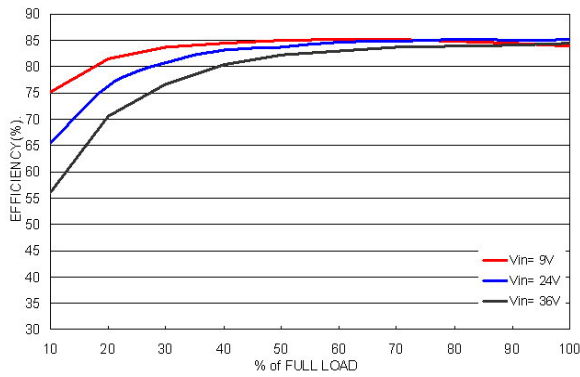

Efficiency versus Output Current

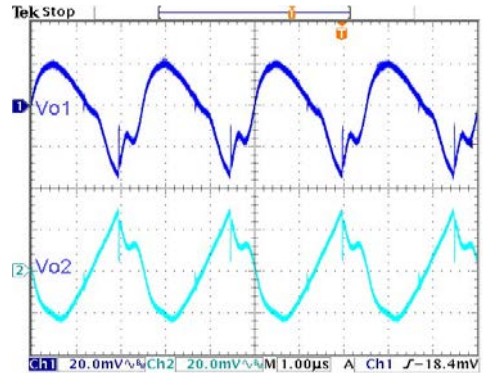

Typical Output Ripple and Noise.
 $V_{in,nom}$; Full Load

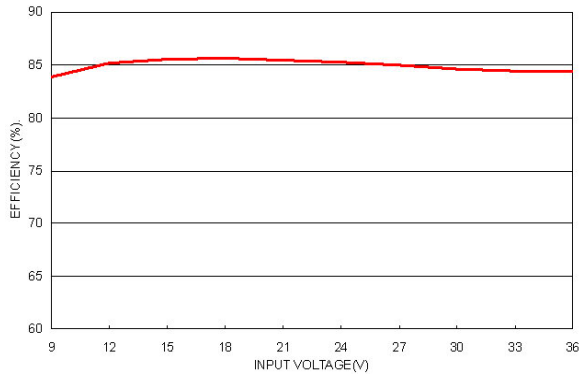

Efficiency versus Input Voltage. Full Load

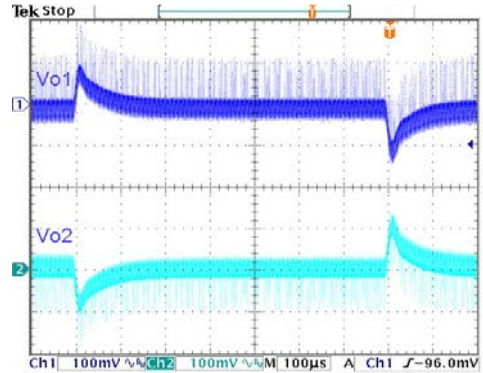

Transient Response to Dynamic Load Change from 100% to 75% to 100% of Full Load ; $V_{in,nom}$

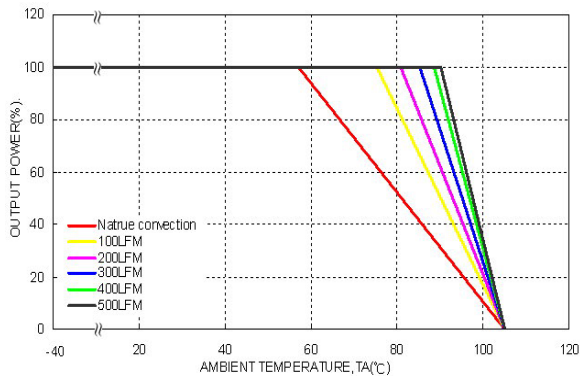

Derating Output Current versus Ambient Temperature and Airflow
 $V_{in} = V_{in,nom}$

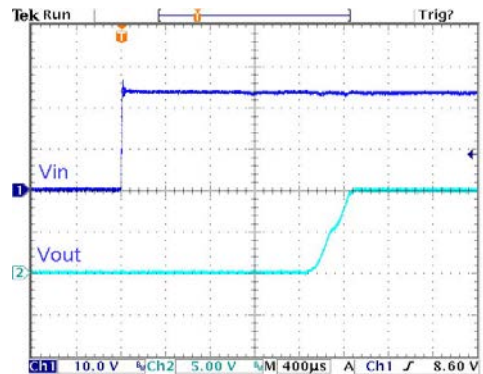

Typical Input Start-Up and Output Rise Characteristic
 $V_{in,nom}$; Full Load

Characteristic Curves (Continued)

All test conditions are at 25°C. The figures are identical for THN 15-2421WI

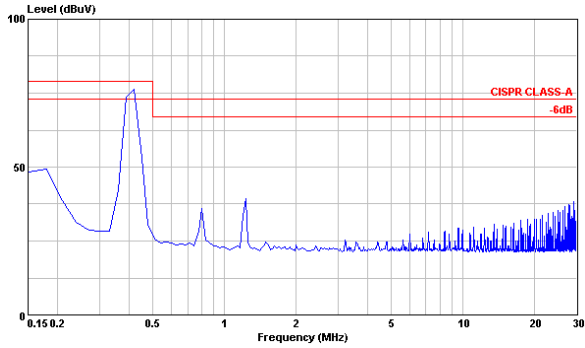

Conduction Emission of EN55022 Class A
 $V_{in,nom}$; Full Load

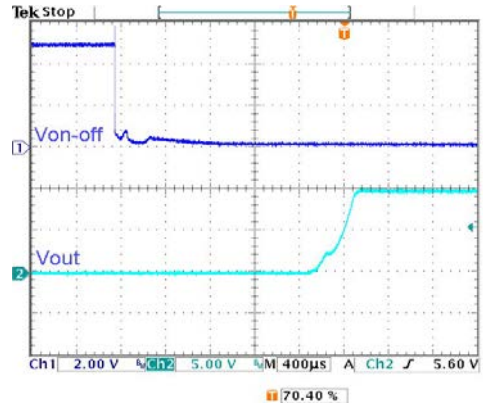

Using ON/OFF Voltage Start-Up and V_{out} Rise Characteristic
 $V_{in,nom}$; Full Load

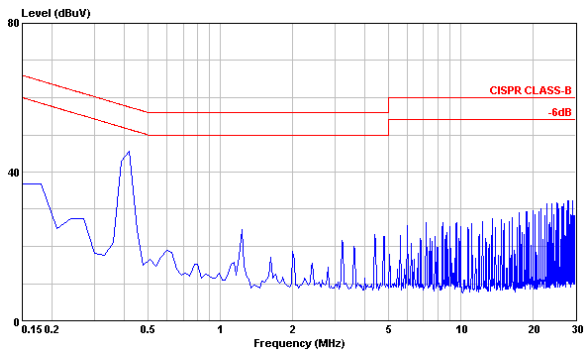

Conduction Emission of EN55022 Class B
 $V_{in,nom}$; Full Load

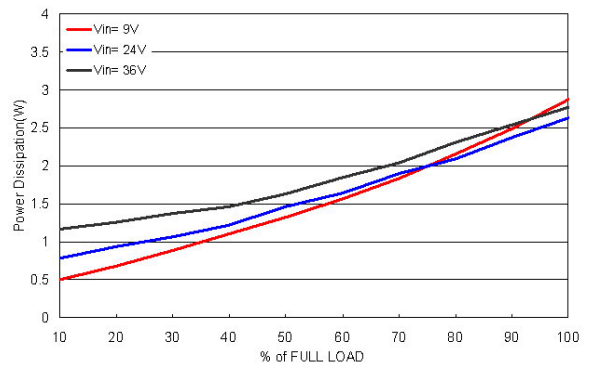

Power Dissipation versus Output Current

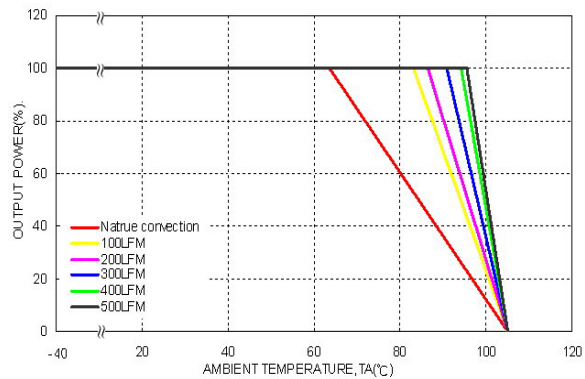

Derating Output Current Versus Ambient Temperature with Heat-Sink and Airflow, $V_{in} = V_{in,nom}$

Characteristic Curves (Continued)

All test conditions are at 25°C. The figures are identical for THN 15-2422WI

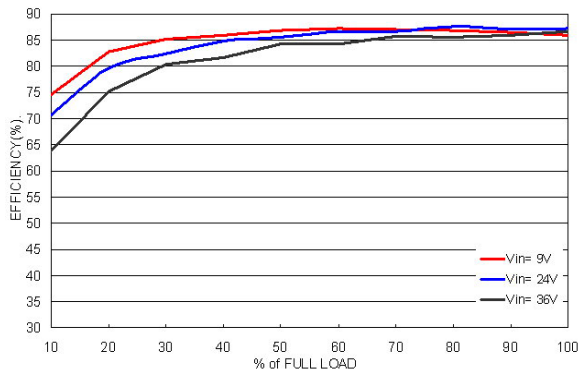

Efficiency versus Output Current

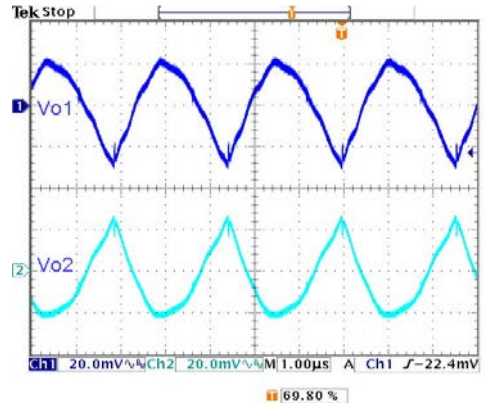

Typical Output Ripple and Noise.
 $V_{in,nom}$; Full Load

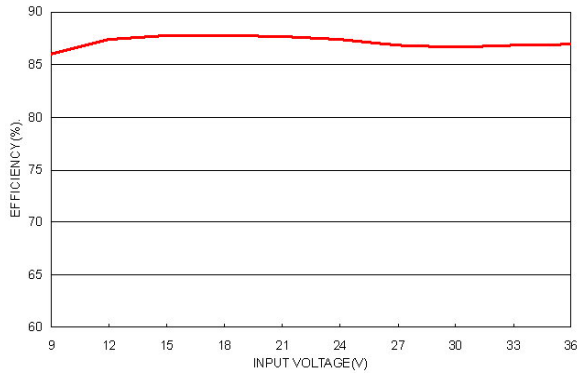

Efficiency versus Input Voltage. Full Load

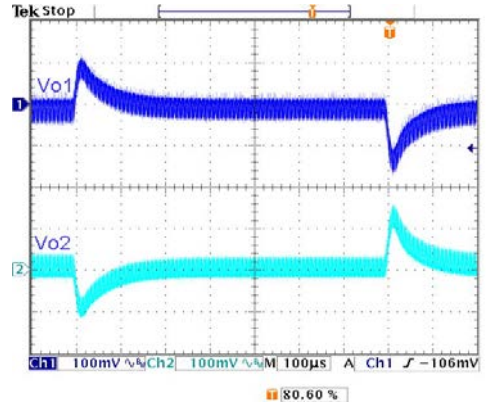

Transient Response to Dynamic Load Change from 100% to 75% to 100% of Full Load ; $V_{in,nom}$

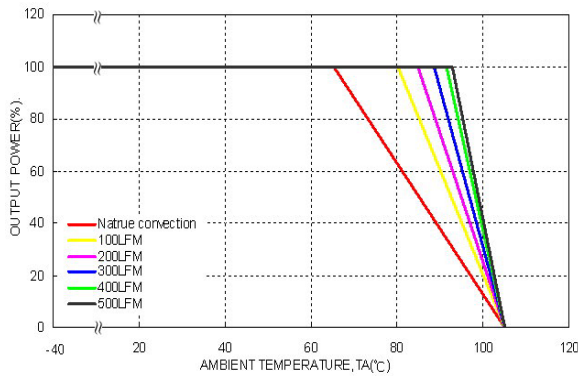

Derating Output Current versus Ambient Temperature and Airflow
 $V_{in} = V_{in,nom}$

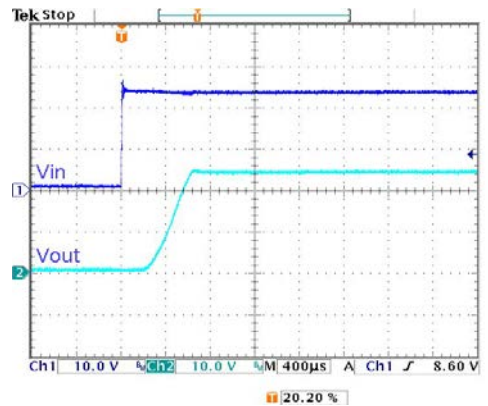

Typical Input Start-Up and Output Rise Characteristic
 $V_{in,nom}$; Full Load

Characteristic Curves (Continued)

All test conditions are at 25°C. The figures are identical for THN 15-2422WI

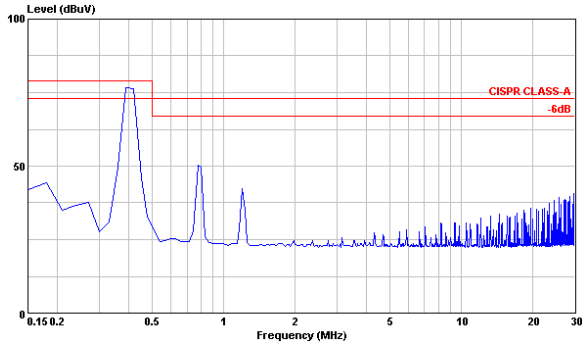

Conduction Emission of EN55022 Class A
 $V_{in,nom}$; Full Load

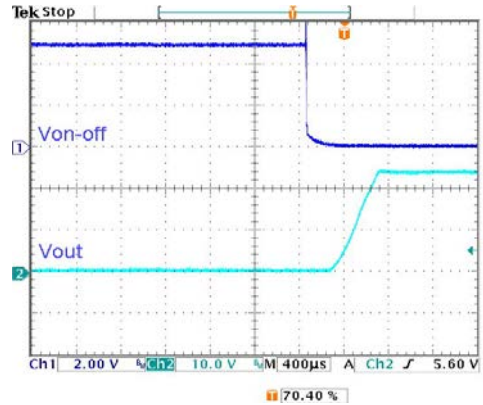

Using ON/OFF Voltage Start-Up and V_{out} Rise Characteristic
 $V_{in,nom}$; Full Load

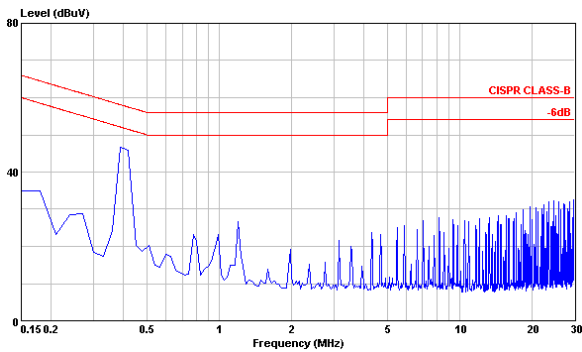

Conduction Emission of EN55022 Class B
 $V_{in,nom}$; Full Load

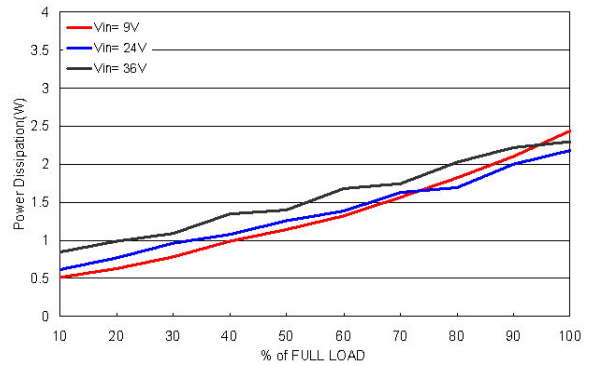

Power Dissipation versus Output Current

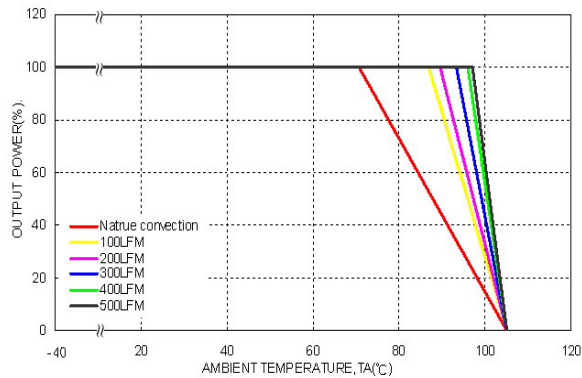

Derating Output Current Versus Ambient Temperature with Heat-Sink and Airflow, $V_{in} = V_{in,nom}$

Characteristic Curves (Continued)

All test conditions are at 25°C. The figures are identical for THN 15-2423WI

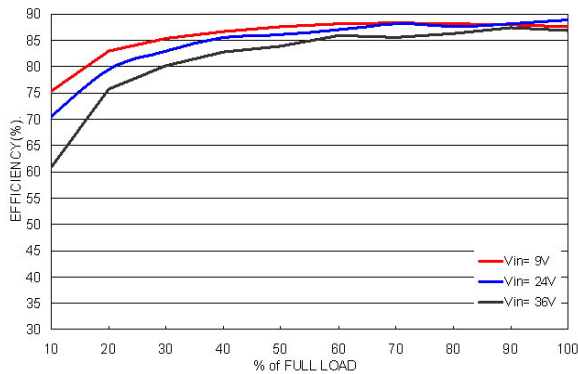

Efficiency versus Output Current

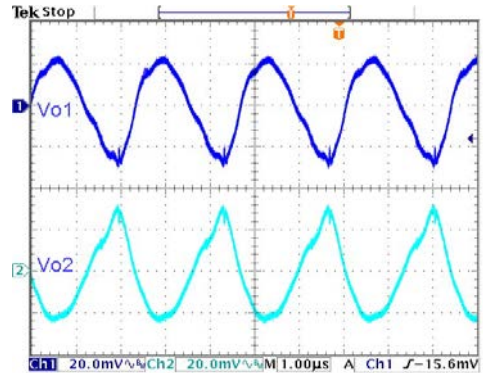

Typical Output Ripple and Noise.
 $V_{in,nom}$; Full Load

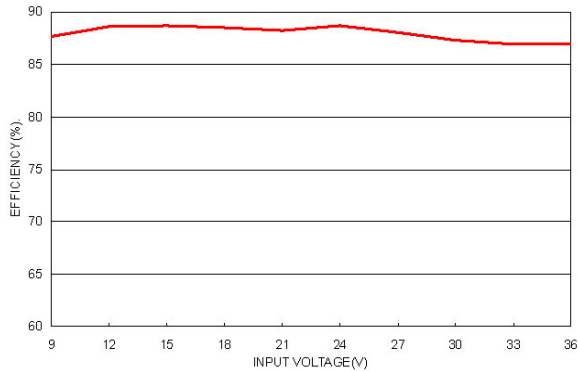

Efficiency versus Input Voltage. Full Load

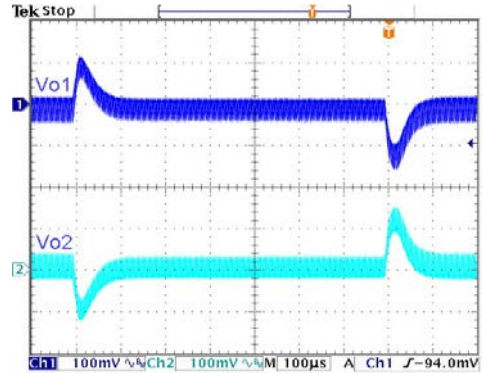

Transient Response to Dynamic Load Change from 100% to 75% to 100% of Full Load ; $V_{in,nom}$

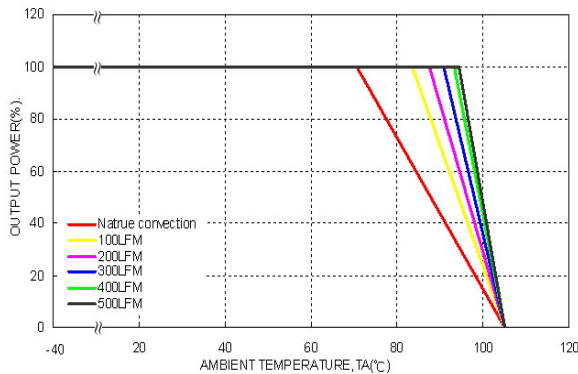

Derating Output Current versus Ambient Temperature and Airflow
 $V_{in} = V_{in,nom}$

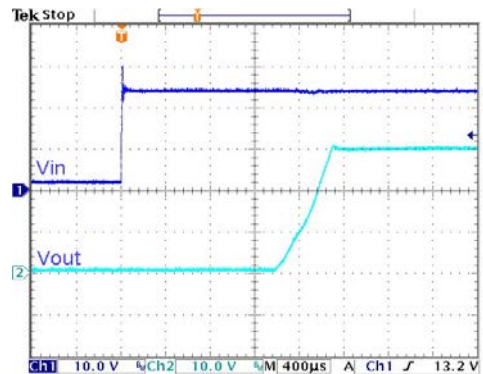

Typical Input Start-Up and Output Rise Characteristic
 $V_{in,nom}$; Full Load

Characteristic Curves (Continued)

All test conditions are at 25°C. The figures are identical for THN 15-2423W1

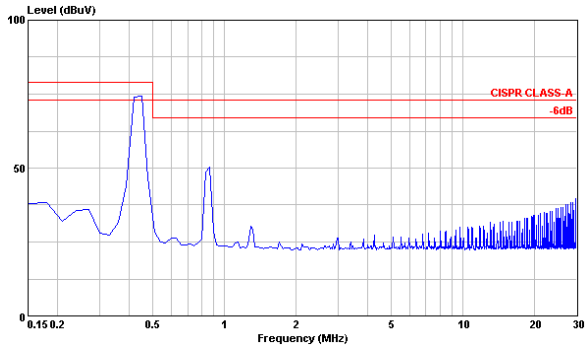

Conduction Emission of EN55022 Class A
 $V_{in,nom}$; Full Load

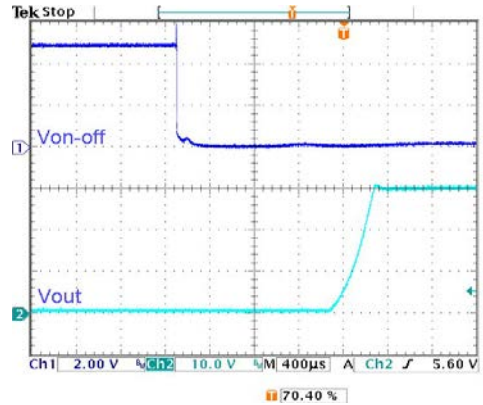

Using ON/OFF Voltage Start-Up and V_{out} Rise Characteristic
 $V_{in,nom}$; Full Load

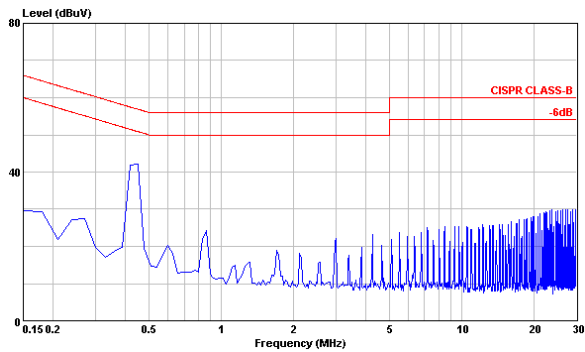

Conduction Emission of EN55022 Class B
 $V_{in,nom}$; Full Load

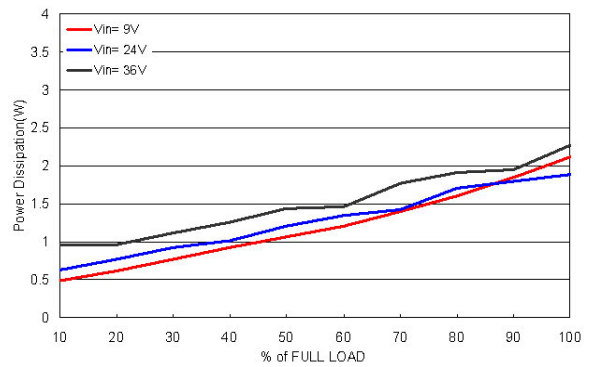

Power Dissipation versus Output Current

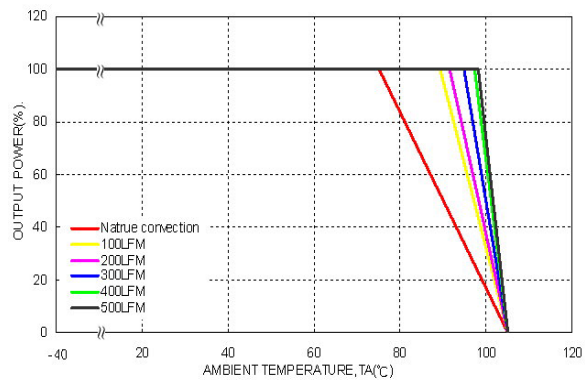

Derating Output Current Versus Ambient Temperature with Heat-Sink and Airflow, $V_{in} = V_{in,nom}$

Characteristic Curves (Continued)

All test conditions are at 25°C. The figures are identical for THN 15-4810WI

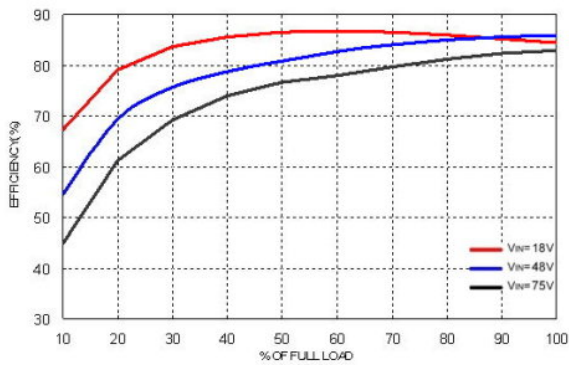

Efficiency versus Output Current

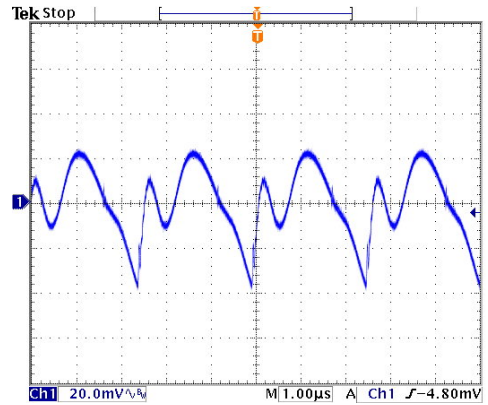

Typical Output Ripple and Noise.
 $V_{in, nom}$; Full Load

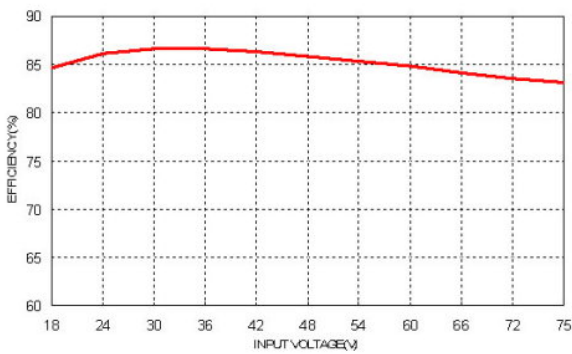

Efficiency versus Input Voltage. Full Load

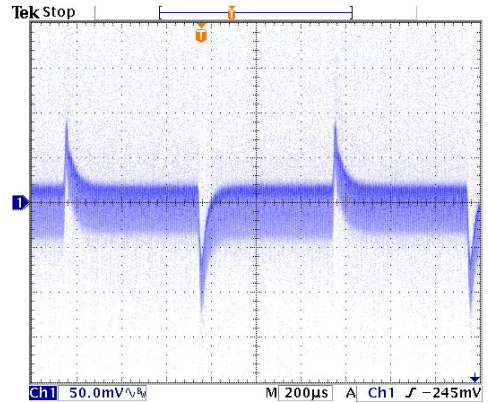

Transient Response to Dynamic Load Change from 100% to 75% to 100% of Full Load ; $V_{in, nom}$

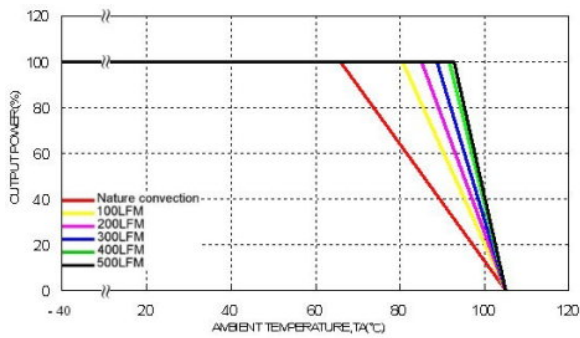

Derating Output Current versus Ambient Temperature and Airflow $V_{in} = V_{in, nom}$

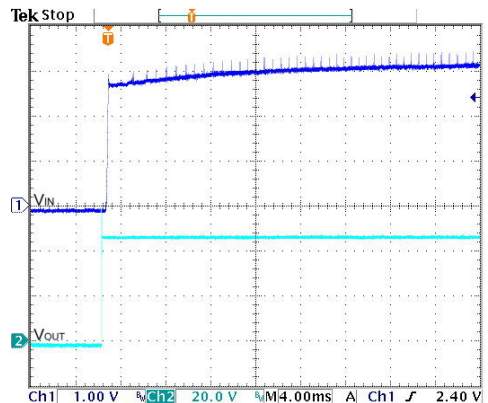

Typical Input Start-Up and Output Rise Characteristic
 $V_{in, nom}$; Full Load

Characteristic Curves (Continued)

All test conditions are at 25°C. The figures are identical for THN 15-4810WI

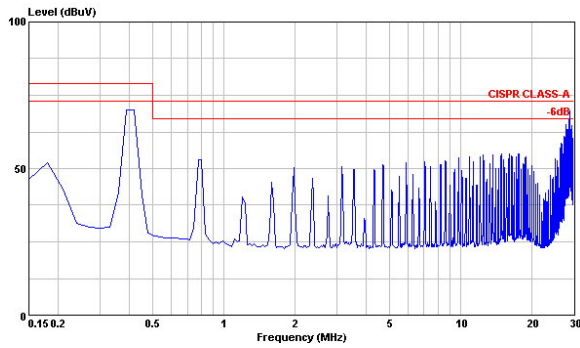

Conduction Emission of EN55022 Class A
 $V_{in, nom}$; Full Load

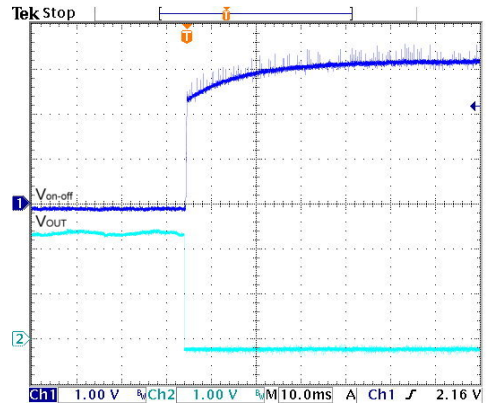

Using ON/OFF Voltage Start-Up and V_{out} Rise Characteristic
 $V_{in, nom}$; Full Load

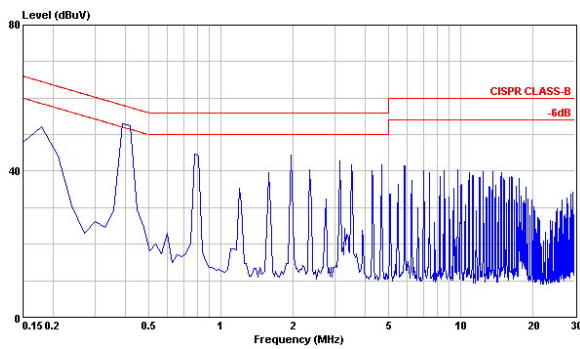

Conduction Emission of EN55022 Class B
 $V_{in, nom}$; Full Load

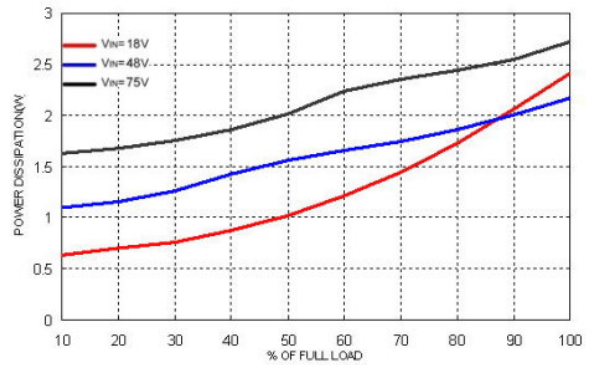

Power Dissipation versus Output Current

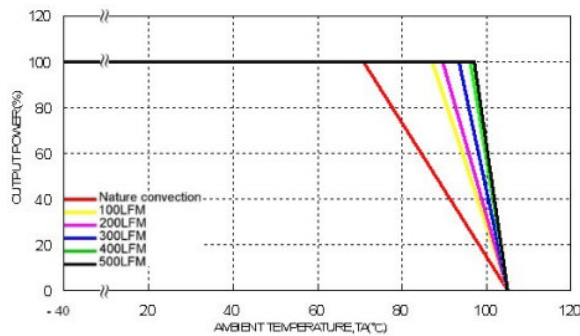

Derating Output Current Versus Ambient Temperature with Heat-Sink and Airflow, $V_{in} = V_{in, nom}$

Characteristic Curves (Continued)

All test conditions are at 25°C. The figures are identical for THN 15-4811WI

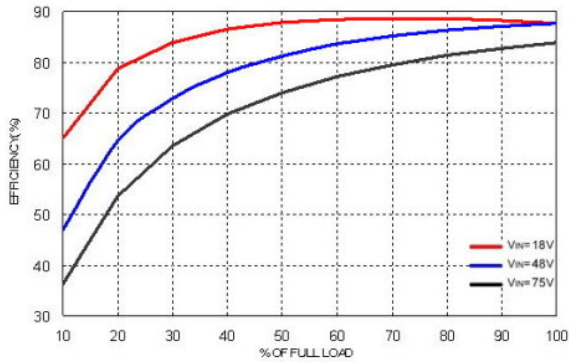

Efficiency versus Output Current

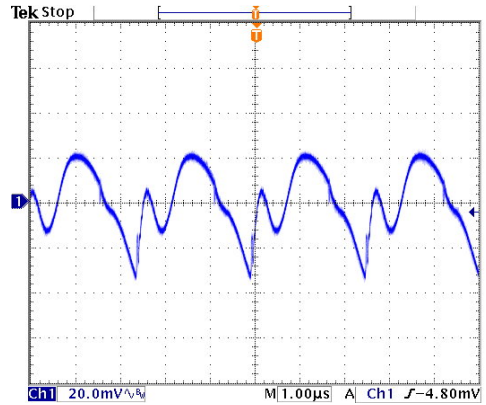

Typical Output Ripple and Noise.

$V_{in,nom}$; Full Load

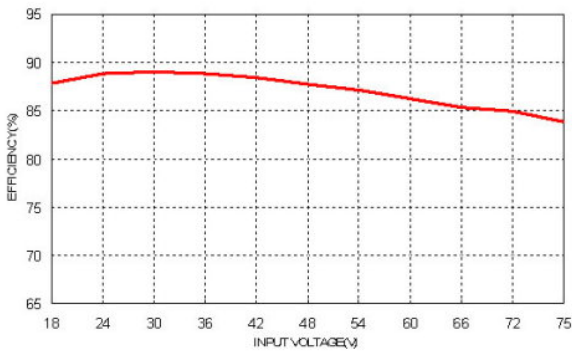

Efficiency versus Input Voltage. Full Load

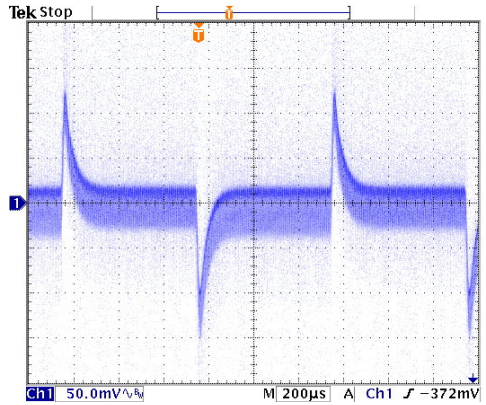

Transient Response to Dynamic Load Change from 100% to 75% to 100% of Full Load ; $V_{in,nom}$

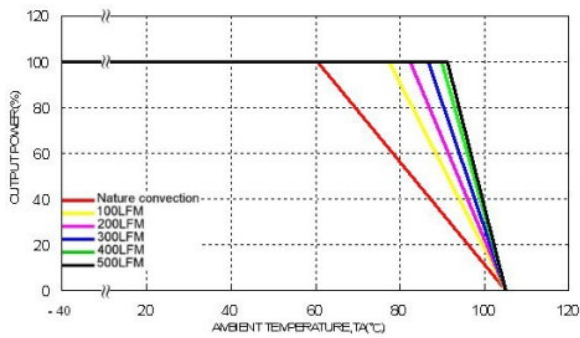

Derating Output Current versus Ambient Temperature and Airflow $V_{in} = V_{in,nom}$

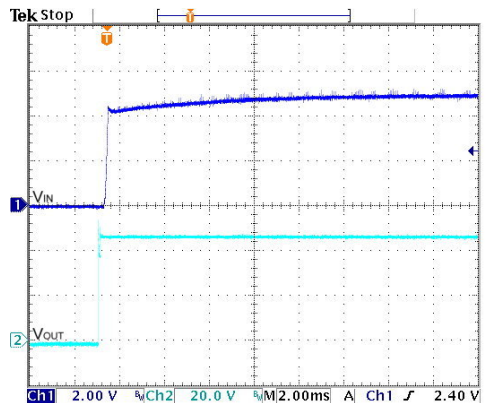

Typical Input Start-Up and Output Rise Characteristic

$V_{in,nom}$; Full Load

Characteristic Curves (Continued)

All test conditions are at 25°C. The figures are identical for THN 15-4811WI

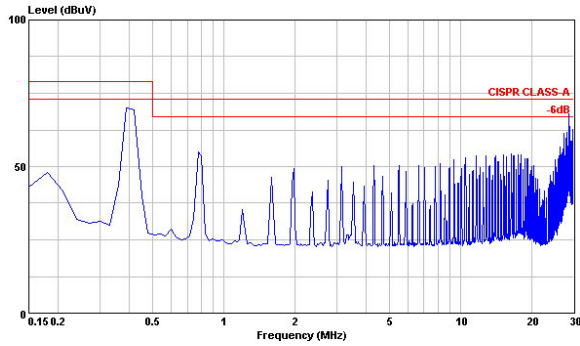

Conduction Emission of EN55022 Class A
 $V_{in, nom}$; Full Load

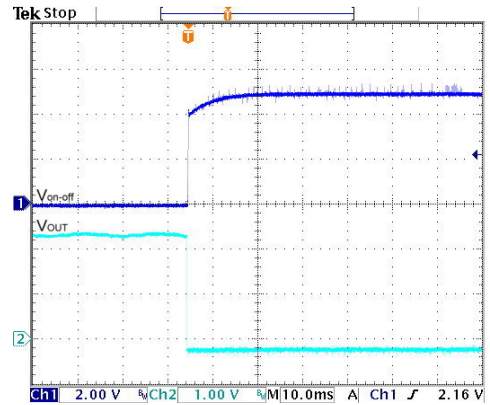

Using ON/OFF Voltage Start-Up and V_{out} Rise Characteristic
 $V_{in, nom}$; Full Load

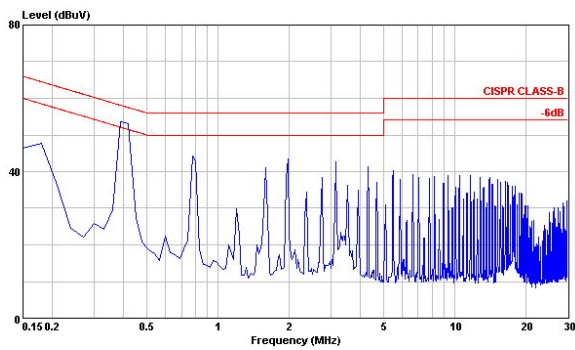

Conduction Emission of EN55022 Class B
 $V_{in, nom}$; Full Load

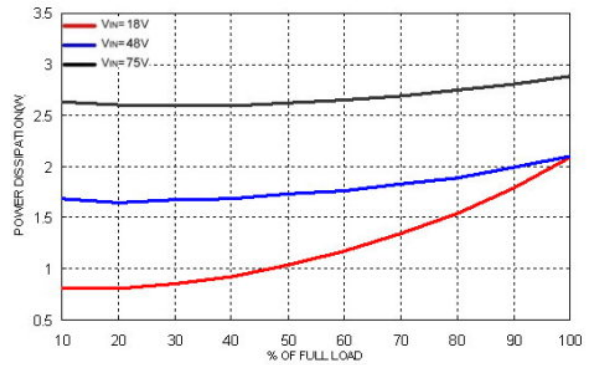

Power Dissipation versus Output Current

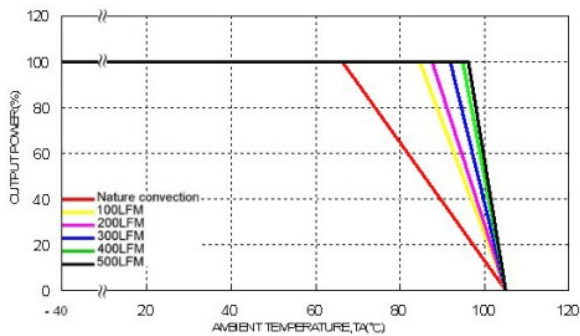

Derating Output Current Versus Ambient Temperature with Heat-Sink and Airflow, $V_{in} = V_{in, nom}$

Characteristic Curves (Continued)

All test conditions are at 25°C. The figures are identical for THN 15-4812WI

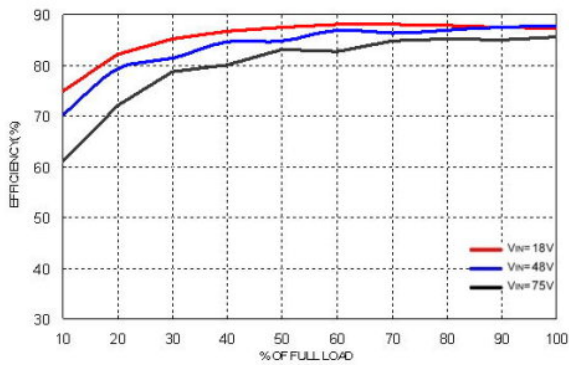

Efficiency versus Output Current

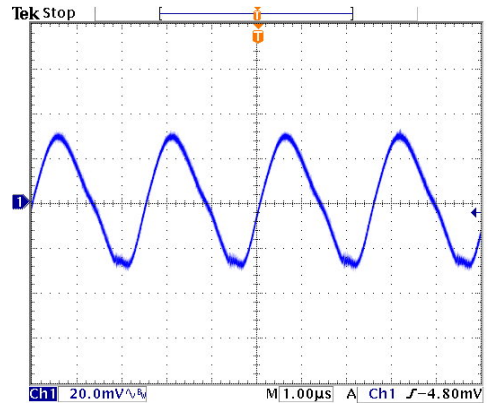

Typical Output Ripple and Noise.

$V_{in, nom}$; Full Load

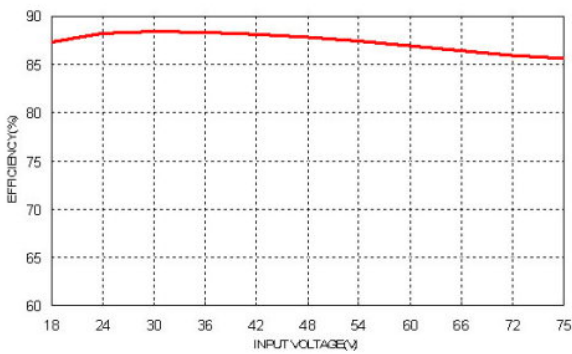

Efficiency versus Input Voltage. Full Load

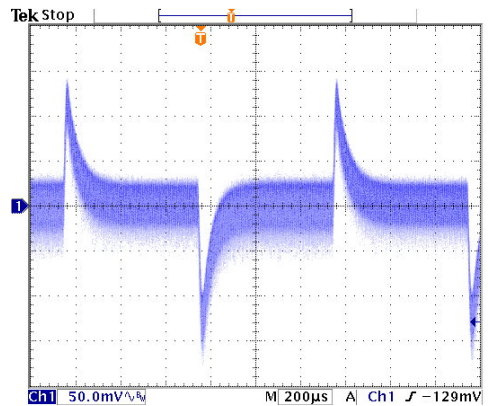

Transient Response to Dynamic Load Change from 100% to 75% to 100% of Full Load ; $V_{in, nom}$

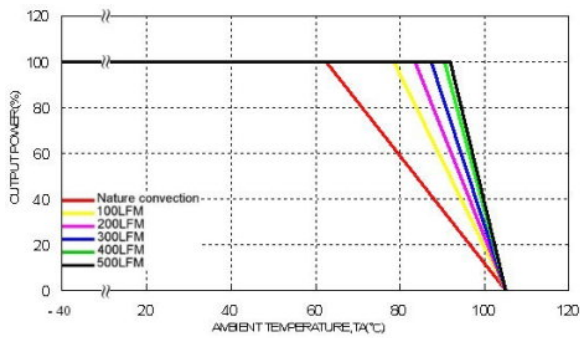

Derating Output Current versus Ambient Temperature and Airflow $V_{in} = V_{in, nom}$

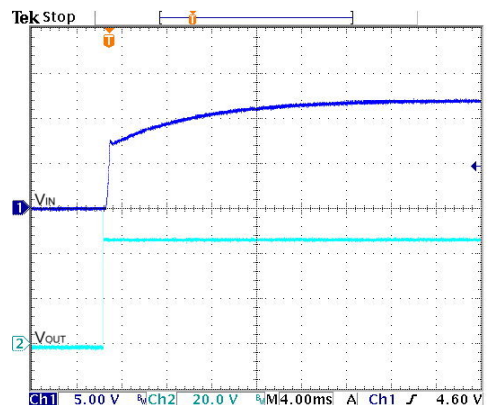

Typical Input Start-Up and Output Rise Characteristic $V_{in, nom}$; Full Load

Characteristic Curves (Continued)

All test conditions are at 25°C. The figures are identical for THN 15-4812WI

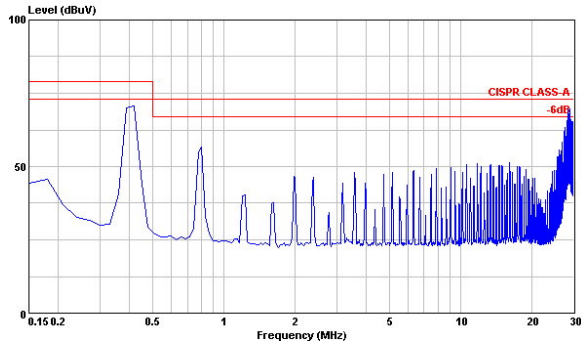

Conduction Emission of EN55022 Class A
 $V_{in, nom}$; Full Load

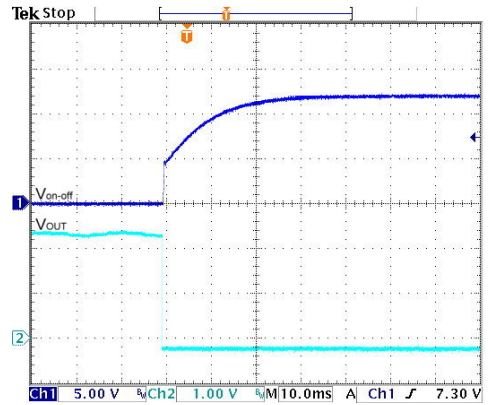

Using ON/OFF Voltage Start-Up and V_{out} Rise Characteristic
 $V_{in, nom}$; Full Load

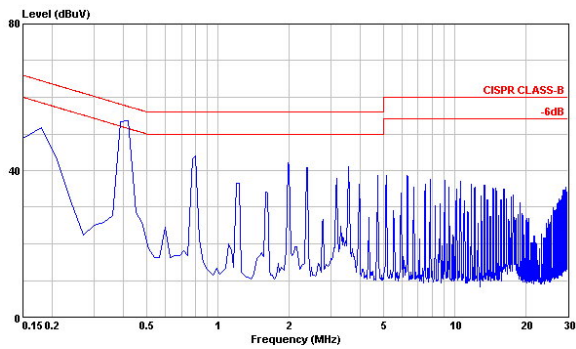

Conduction Emission of EN55022 Class B
 $V_{in, nom}$; Full Load

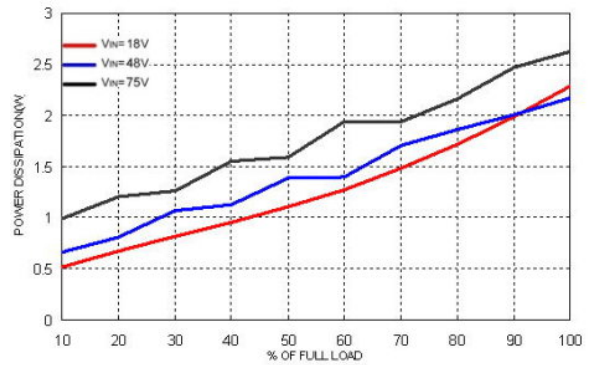

Power Dissipation versus Output Current

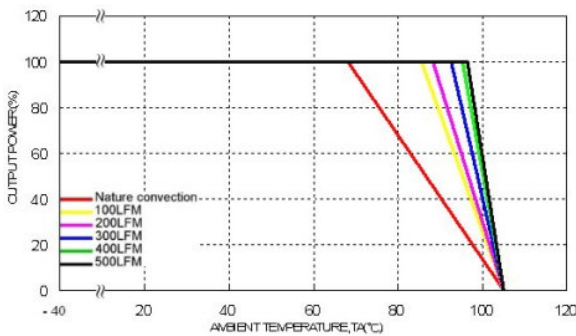

Derating Output Current Versus Ambient Temperature with Heat-Sink and Airflow, $V_{in} = V_{in, nom}$

Characteristic Curves (Continued)

All test conditions are at 25°C. The figures are identical for THN 15-4813WI

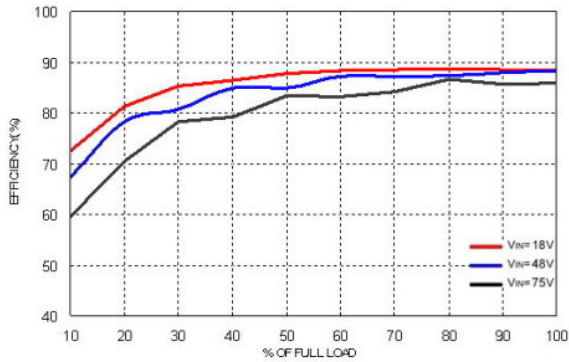

Efficiency versus Output Current

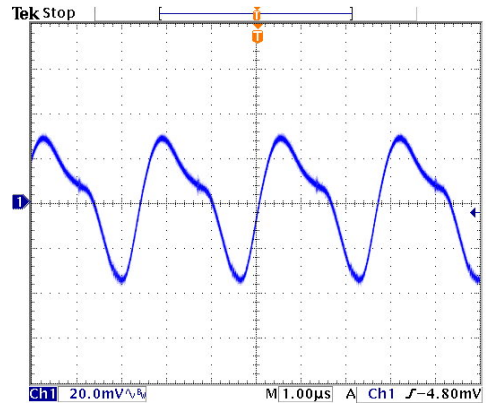

Typical Output Ripple and Noise.

$V_{in, nom}$; Full Load

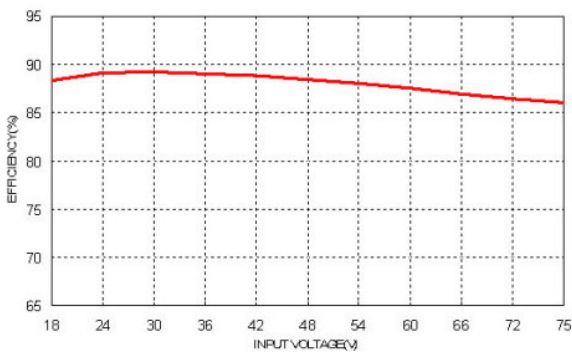

Efficiency versus Input Voltage. Full Load

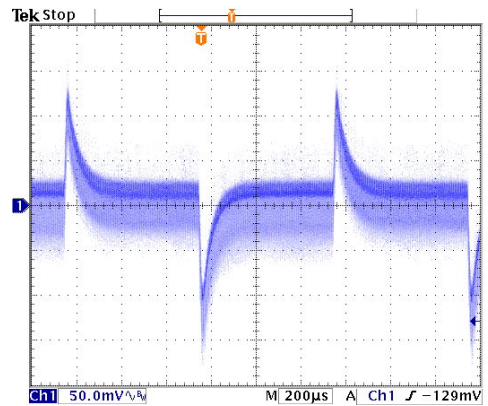

Transient Response to Dynamic Load Change from 100% to 75% to 100% of Full Load ; $V_{in, nom}$

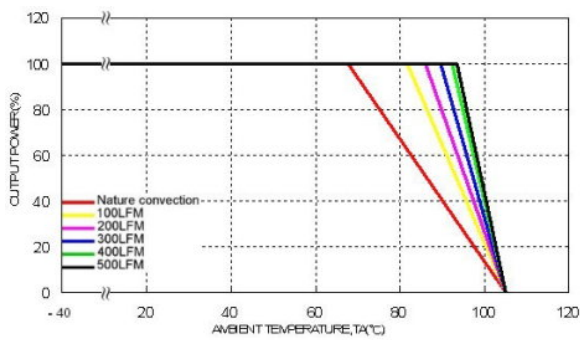

Derating Output Current versus Ambient Temperature and Airflow $V_{in} = V_{in, nom}$

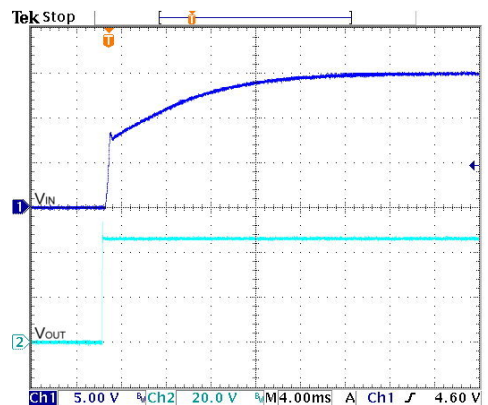

Typical Input Start-Up and Output Rise Characteristic

$V_{in, nom}$; Full Load

Characteristic Curves (Continued)

All test conditions are at 25°C. The figures are identical for THN 15-4813WI

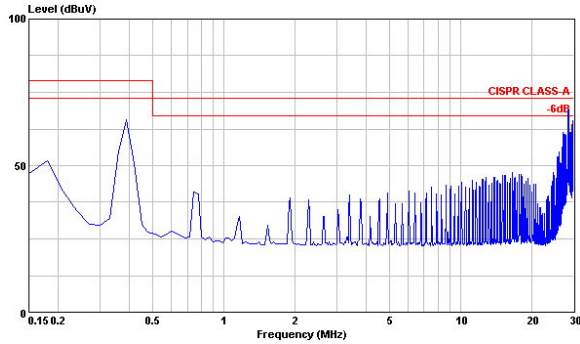

Conduction Emission of EN55022 Class A
 $V_{in, nom}$; Full Load

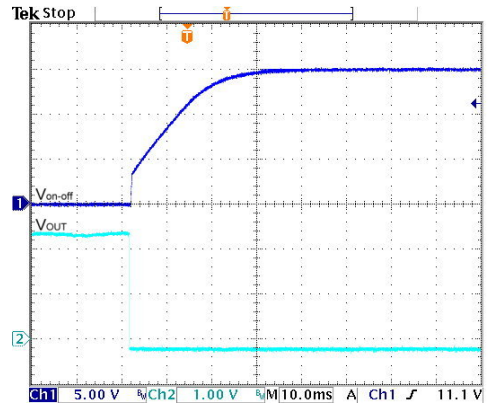

Using ON/OFF Voltage Start-Up and V_{out} Rise Characteristic
 $V_{in, nom}$; Full Load

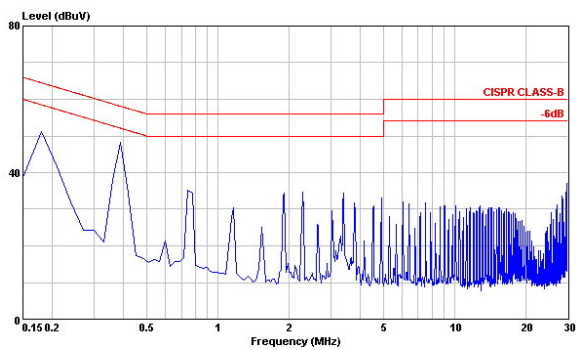

Conduction Emission of EN55022 Class B
 $V_{in, nom}$; Full Load

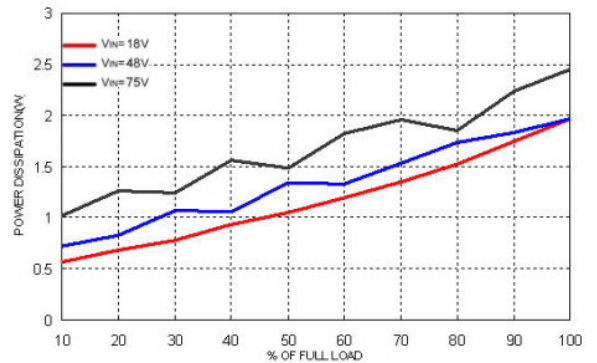

Power Dissipation versus Output Current

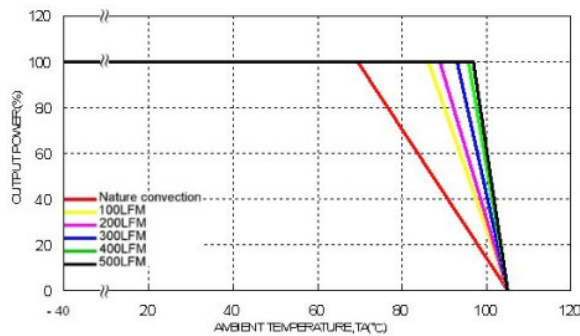

Derating Output Current Versus Ambient Temperature with Heat-Sink and Airflow, $V_{in} = V_{in, nom}$

Characteristic Curves (Continued)

All test conditions are at 25°C. The figures are identical for THN 15-4821WI

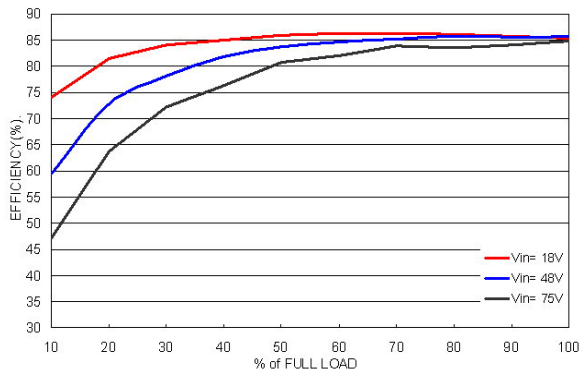

Efficiency versus Output Current

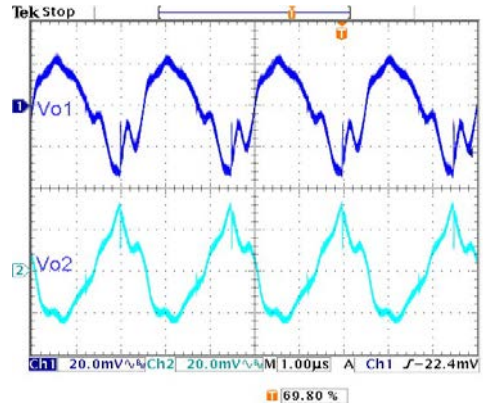

Typical Output Ripple and Noise.
 $V_{in,nom}$; Full Load

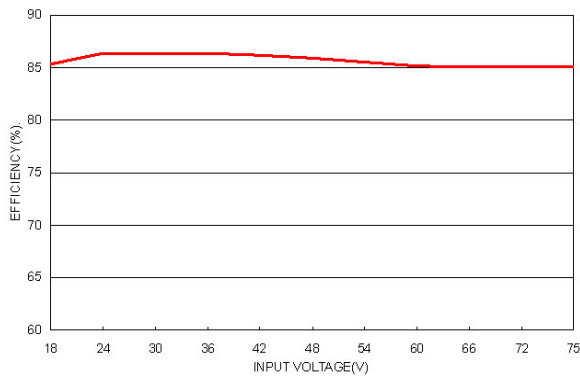

Efficiency versus Input Voltage. Full Load

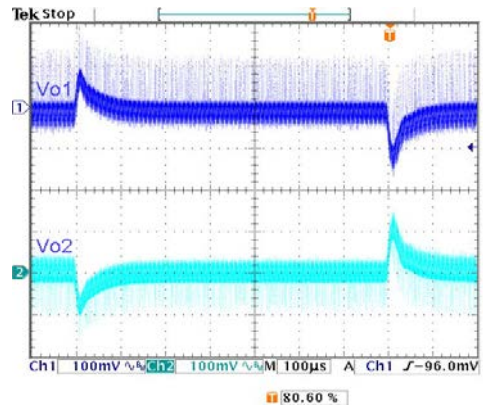

Transient Response to Dynamic Load Change from 100% to 75% to 100% of Full Load ; $V_{in,nom}$

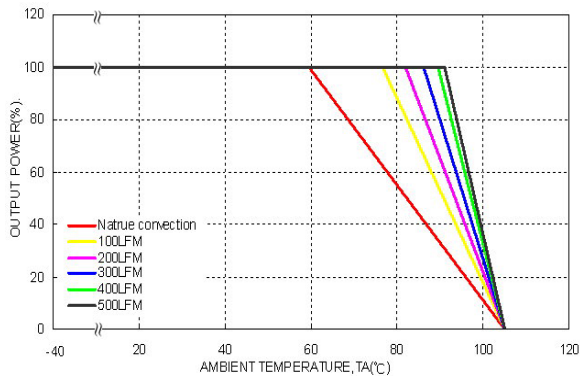

Derating Output Current versus Ambient Temperature and Airflow
 $V_{in} = V_{in,nom}$

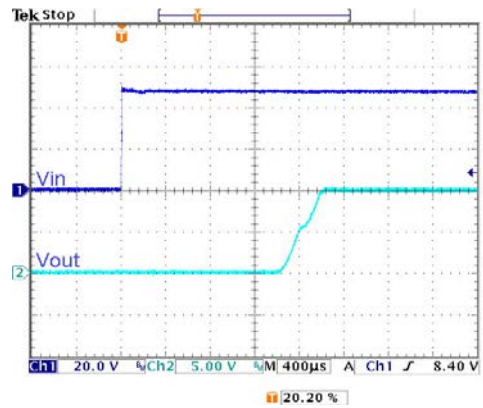

Typical Input Start-up and Output Rise Characteristic
 $V_{in,nom}$; Full Load

Characteristic Curves (Continued)

All test conditions are at 25°C. The figures are identical for THN 15-4821WI

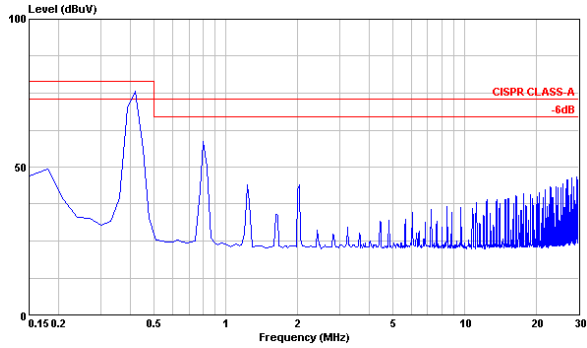

Conduction Emission of EN55022 Class A
 $V_{in,nom}$; Full Load

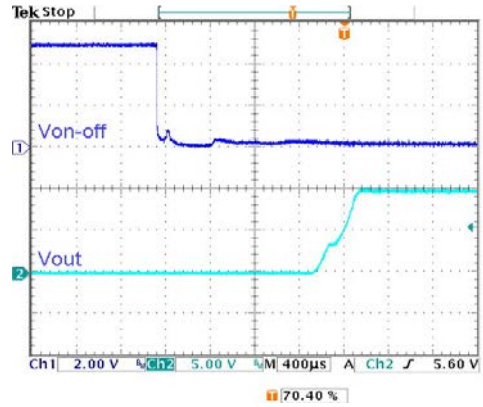

Using ON/OFF Voltage Start-Up and V_{out} Rise Characteristic
 $V_{in,nom}$; Full Load

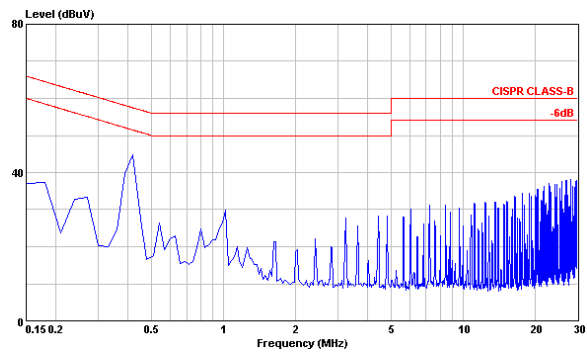

Conduction Emission of EN55022 Class B
 $V_{in,nom}$; Full Load

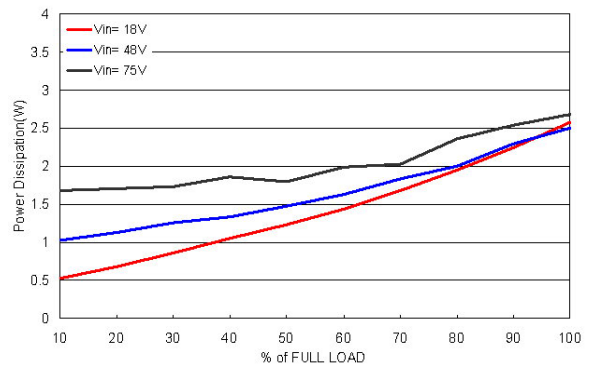

Power Dissipation versus Output Current

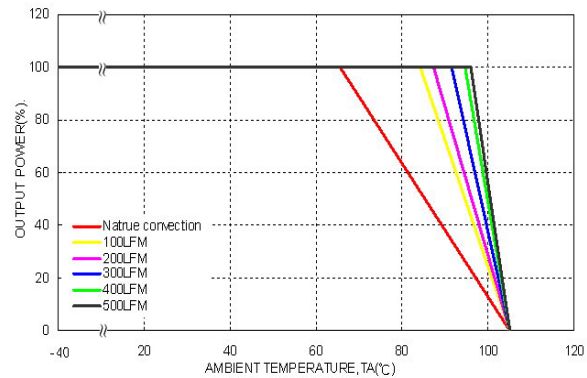

Derating Output Current Versus Ambient Temperature with
 Heat-Sink and Airflow, $V_{in} = V_{in,nom}$

Characteristic Curves (Continued)

All test conditions are at 25°C. The figures are identical for THN 15-4822WI

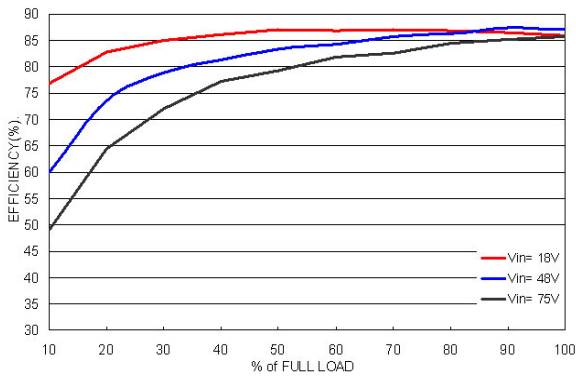

Efficiency versus Output Current

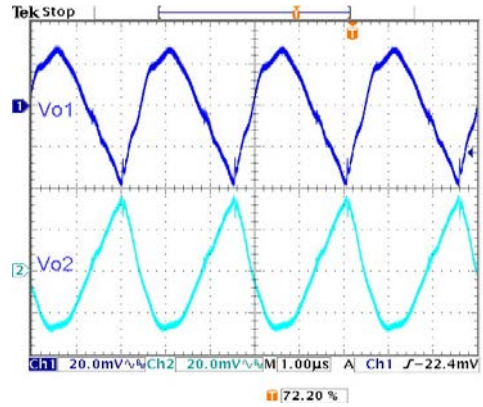

Typical Output Ripple and Noise.
 $V_{in,nom}$; Full Load

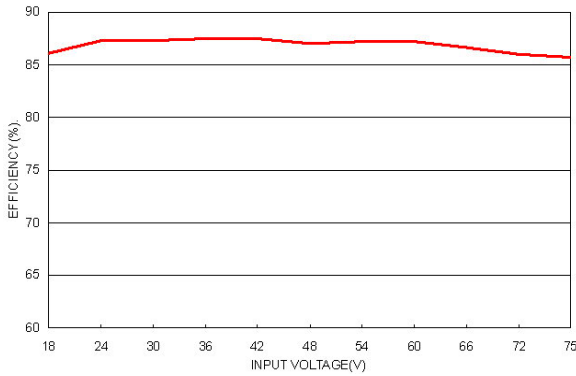

Efficiency versus Input Voltage. Full Load

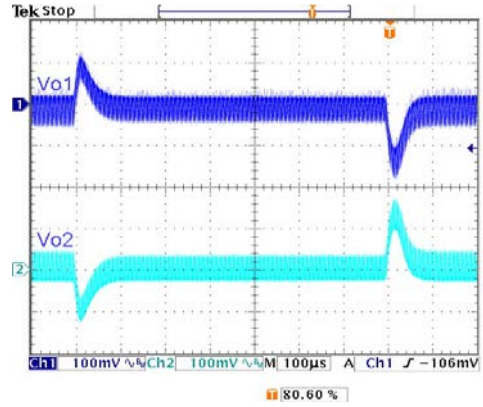

Transient Response to Dynamic Load Change from 100% to 75% to 100% of Full Load ; $V_{in,nom}$

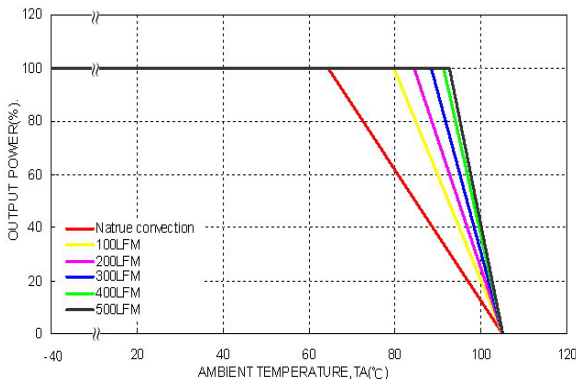

Derating Output Current versus Ambient Temperature and Airflow
 $V_{in} = V_{in,nom}$

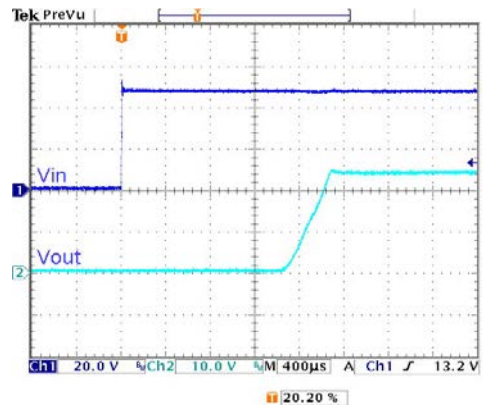

Typical Input Start-Up and Output Rise Characteristic
 $V_{in,nom}$; Full Load

Characteristic Curves (Continued)

All test conditions are at 25°C. The figures are identical for THN 15-4822WI

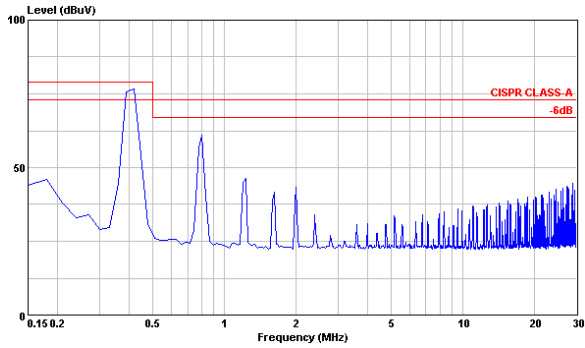

Conduction Emission of EN55022 Class A
 $V_{in,nom}$; Full Load

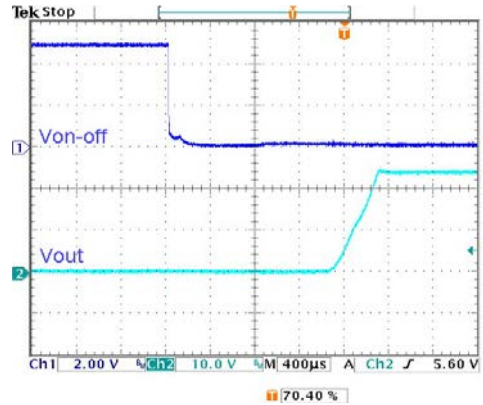

Using ON/OFF Voltage Start-Up and V_{out} Rise Characteristic
 $V_{in,nom}$; Full Load

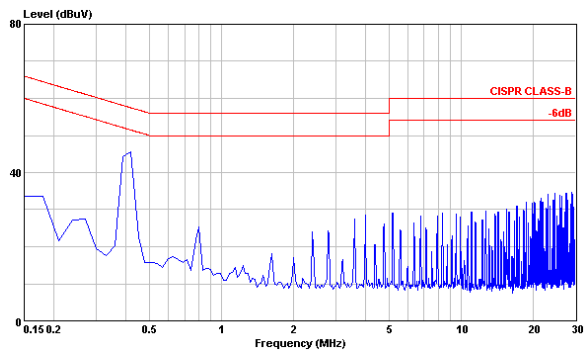

Conduction Emission of EN55022 Class B
 $V_{in,nom}$; Full Load

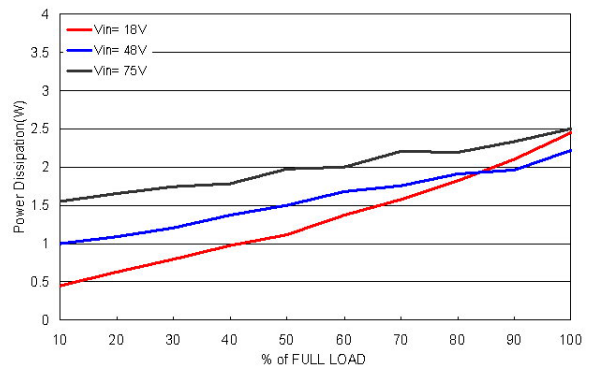

Power Dissipation versus Output Current

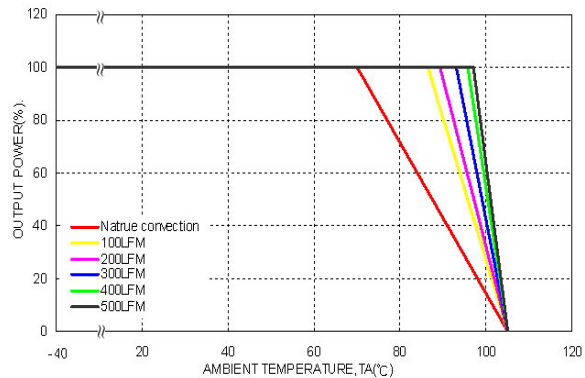

Derating Output Current Versus Ambient Temperature with Heat-Sink and Airflow, $V_{in} = V_{in,nom}$

Characteristic Curves (Continued)

All test conditions are at 25°C. The figures are identical for THN 15-4823WI

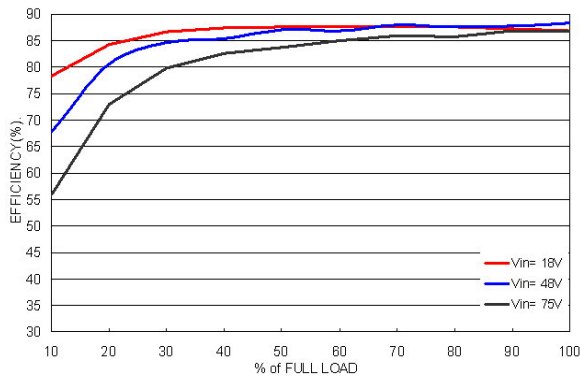

Efficiency versus Output Current

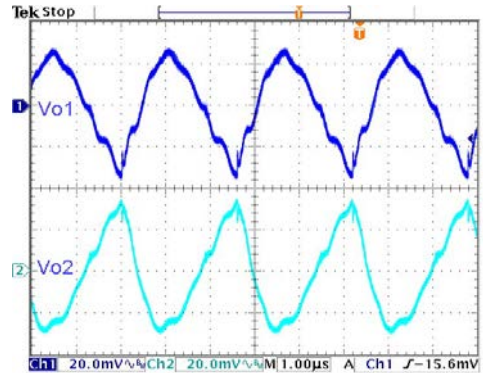

Typical Output Ripple and Noise.
 $V_{in,nom}$; Full Load

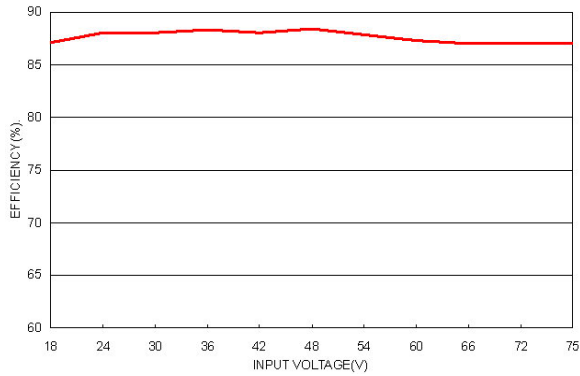

Efficiency versus Input Voltage. Full Load

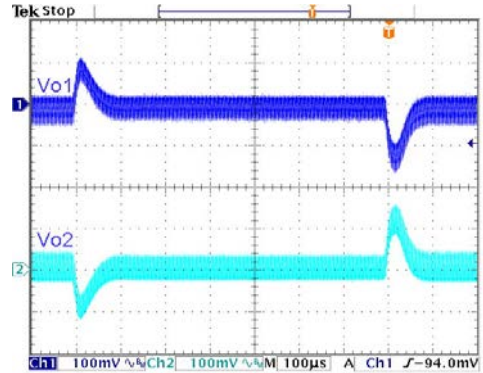

Transient Response to Dynamic Load Change from 100% to 75% to 100% of Full Load ; $V_{in,nom}$

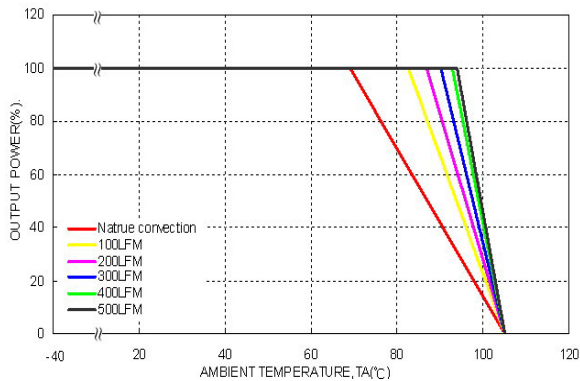

Derating Output Current versus Ambient Temperature and Airflow
 $V_{in} = V_{in,nom}$

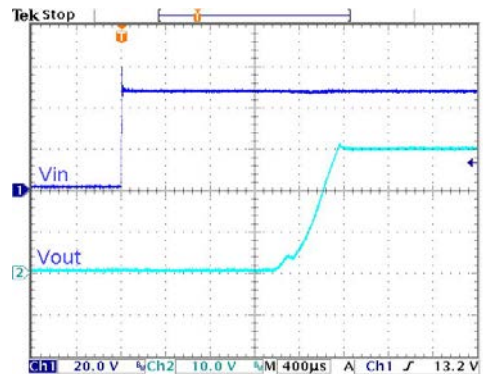

Typical Input Start-Up and Output Rise Characteristic
 $V_{in,nom}$; Full Load

Characteristic Curves (Continued)

All test conditions are at 25°C. The figures are identical for THN 15-4823WI

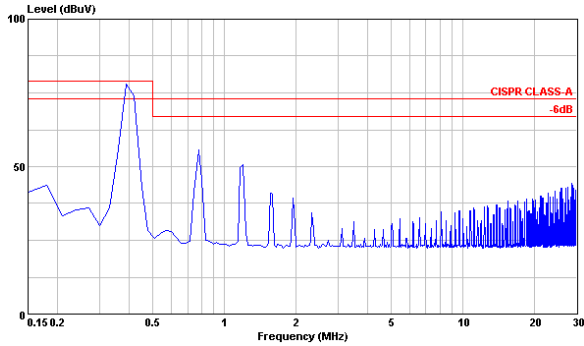

Conduction Emission of EN55022 Class A
 $V_{in,nom}$; Full Load

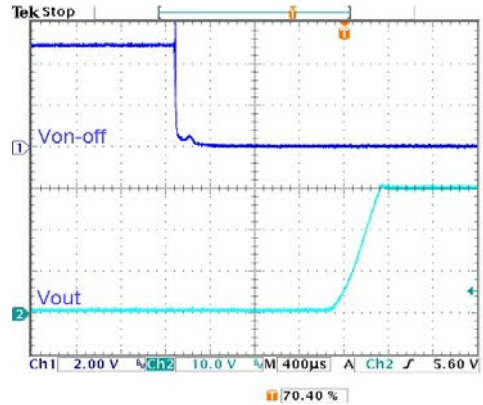

Using ON/OFF Voltage Start-Up and V_{out} Rise Characteristic
 $V_{in,nom}$; Full Load

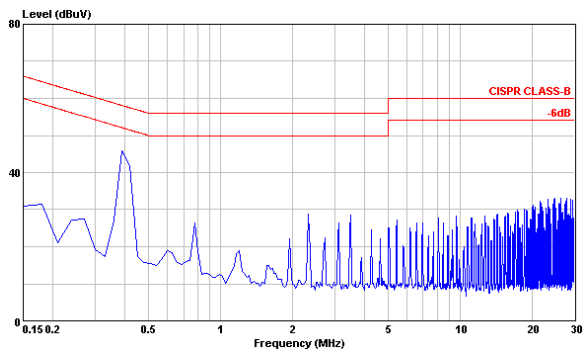

Conduction Emission of EN55022 Class B
 $V_{in,nom}$; Full Load

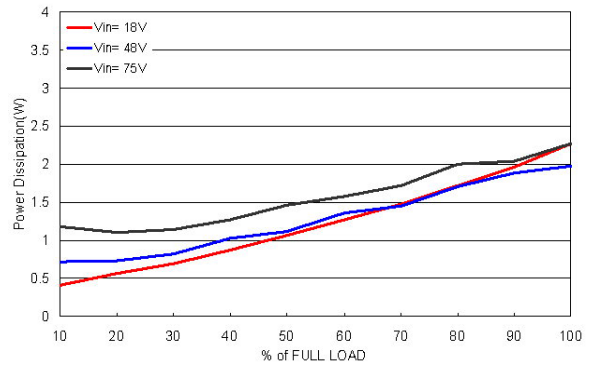

Power Dissipation versus Output Current

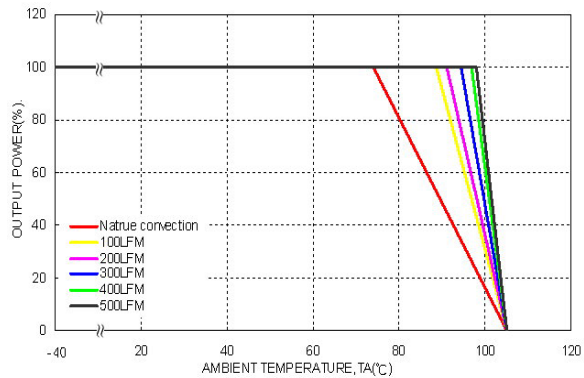

Derating Output Current Versus Ambient Temperature with Heat-Sink and Airflow, $V_{in} = V_{in,nom}$

Testing Configurations

Input reflected-ripple current measurement test up

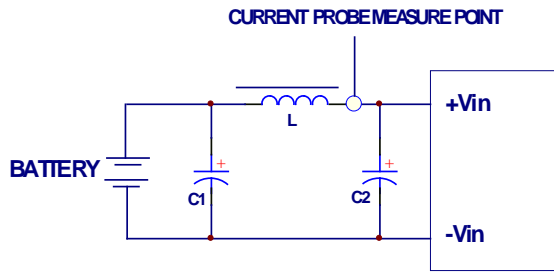

Component	Value	Voltage	Reference
L	12µH	----	----
C1	10µF	100V	Aluminum Electrolytic Capacitor
C2	10µF	100V	Aluminum Electrolytic Capacitor

Peak-to-peak output ripple & noise measurement test up

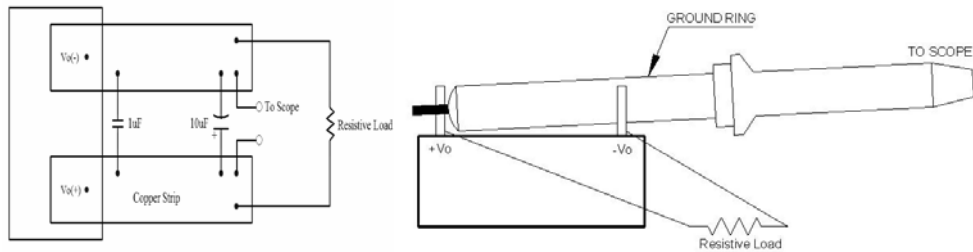

Output voltage and efficiency measurement test up

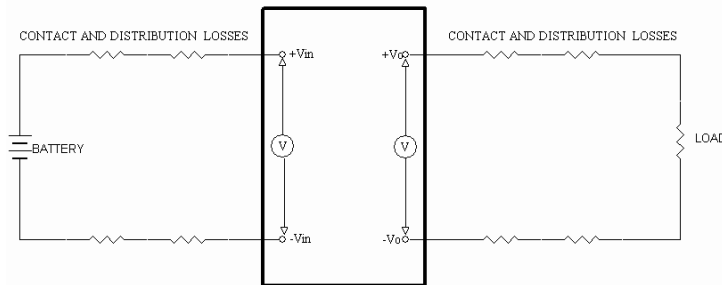

Note: All measurements are taken at the module terminals.

$$Efficiency = \left(\frac{V_o \times I_o}{V_{in} \times I_{in}} \right) \times 100\%$$

EMC considerations (Single Output)

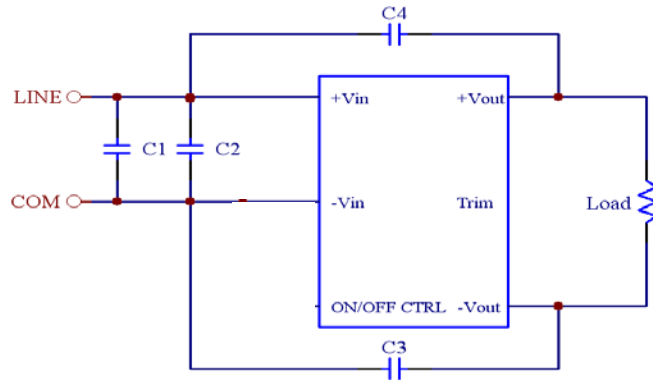

Suggested schematic to comply with EN55022 conducted noise emission Class A

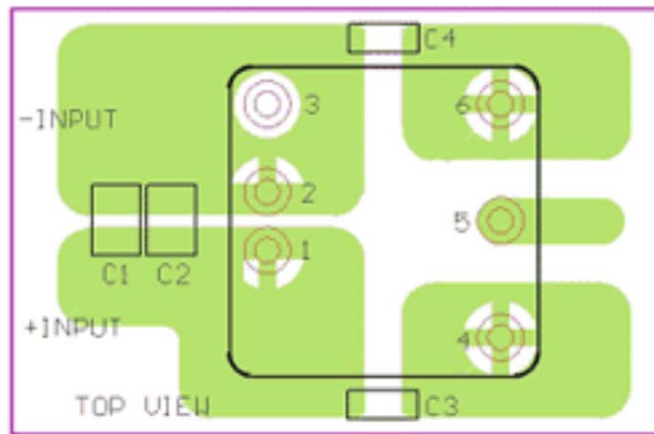

Recommended layout with input filter

To comply with the conducted noise emissions according to EN55022 CLASS A following components are required:

THN 15-24xxWI

Component	Value	Voltage	Reference
C1	6.8µF	50V	1812 MLCC
C2	6.8µF	50V	1812 MLCC
C3, C4	470pF	2KV	1808 MLCC

THN 15-48xxWI

Component	Value	Voltage	Reference
C1	2.2µF	100V	1812 MLCC
C2	2.2µF	100V	1812 MLCC
C3, C4	470pF	3KV	1808 MLCC

EMC considerations (Single Output)

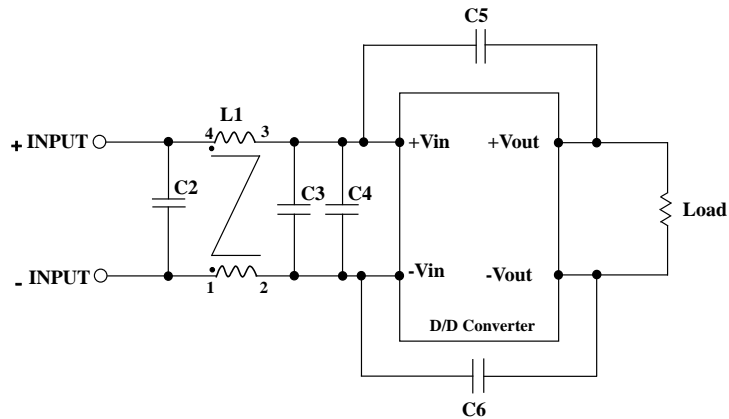

Suggested schematic to comply with EN55022 conducted noise emission Class B

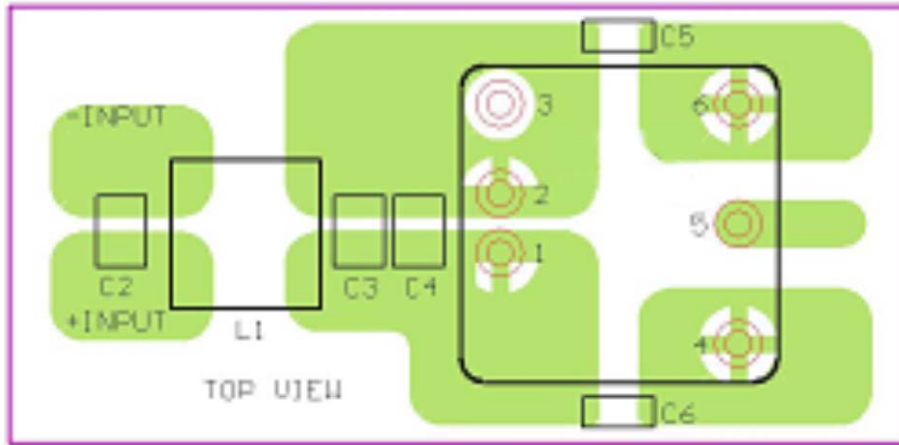

Recommended layout with input filter

To comply with the conducted noise emissions according to EN55022 CLASS B following components are required:

THN 15-24xxWI

Component	Value	Voltage	Reference
C2, C3	6.8 μ F	50V	1812 MLCC
C4	----	----	----
C5, C6	470pF	2KV	1808 MLCC
L1	325 μ H	----	Common Choke, P/N: TCK-050

THN 15-48xxWI

Component	Value	Voltage	Reference
C2, C3	2.2 μ F	100V	1812 MLCC
C4	2.2 μ F	100V	1812 MLCC
C5, C6	470pF	2KV	1808 MLCC
L1	325 μ H	----	Common Choke, P/N: TCK-050

EMC considerations (Dual Output)

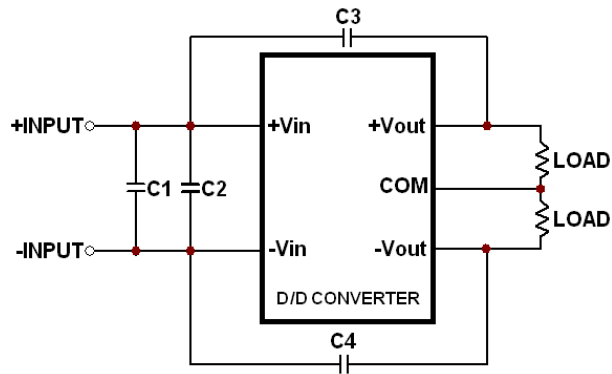

Suggested schematic to comply with EN55022 conducted noise emission Class A

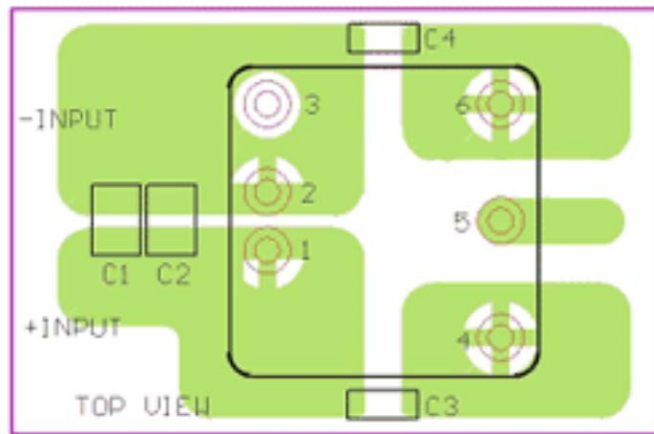

Recommended layout with input filter

To comply with the conducted noise emissions according to EN55022 CLASS A following components are required:

THN 15-24xxWI

Component	Value	Voltage	Reference
C1	6.8µF	50V	1812 MLCC
C2	6.8µF	50V	1812 MLCC
C3, C4	470pF	3KV	1808 MLCC

THN 15-48xxWI

Component	Value	Voltage	Reference
C1	2.2µF	100V	1812 MLCC
C2	2.2µF	100V	1812 MLCC
C3, C4	470pF	3KV	1808 MLCC

EMC considerations (Dual Output)

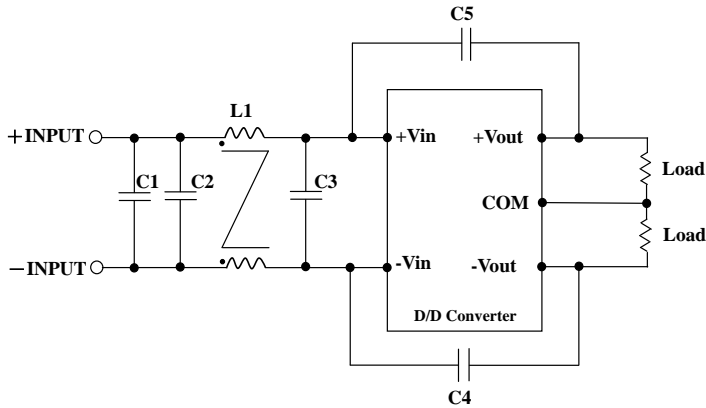

Suggested schematic to comply with EN55022 conducted noise emission Class B

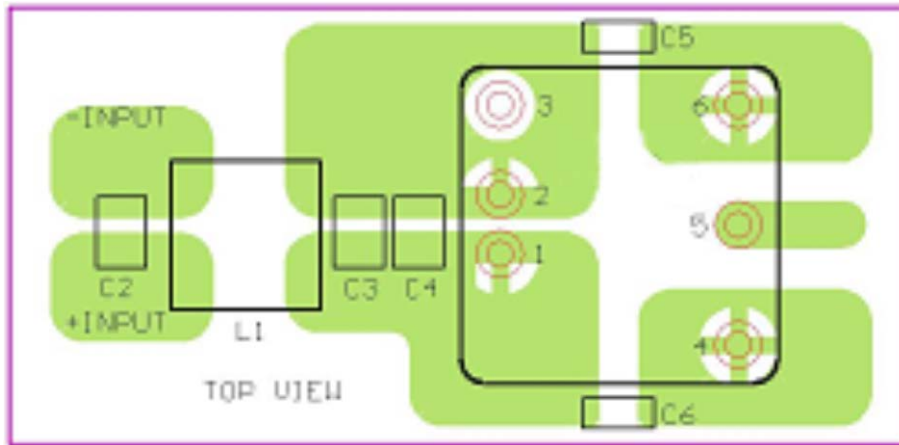

Recommended layout with input filter

To comply with the conducted noise emissions according to EN55022 CLASS B following components are required:

THN 15-24xxWI

Component	Value	Voltage	Reference
C1, C3	6.8 μ F	50V	1812 MLCC
C2	----	----	----
C4, C5	470pF	3KV	1808 MLCC
L1	325 μ H	----	Common Choke, P/N: TCK-050

THN 15-48xxWI

Component	Value	Voltage	Reference
C1, C3	2.2 μ F	100V	1812 MLCC
C2	2.2 μ F	100V	1812 MLCC
C4, C5	1000pF	3KV	1808 MLCC
L1	325 μ H	----	Common Choke, P/N: TCK-050

EMC considerations

This Common Choke L1 has been define as follow:

- TCK-050
 - L: 325 μ H \pm 35% / DCR: 35 Ω , max
 - A height: 8.8 mm, Max
- Test condition: 100KHz / 100mV
- Recommended through hole: Φ 0.8mm
- All dimensions in millimeters

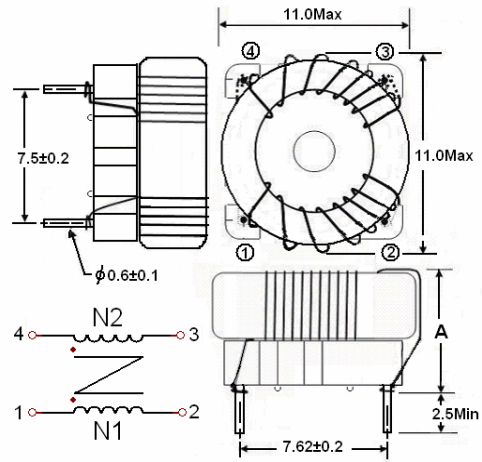

Input Source Impedance

The power module should be connected to a low impedance input source. Highly inductive source impedance can affect the stability of the power module. Input external C-L-C filter is recommended to minimize input reflected ripple current. The inductor is simulated source impedance of 12 μ H and capacitor is Nippon Chemi-con KZE series 10 μ F/100V&10 μ F/100V. The capacitor must be equipped as close as possible to the input terminals of the power module for lower impedance.

Output Over Current Protection

When excessive output currents occur in the system, circuit protection is required on all power supplies. Normally, overload current is maintained at approximately about 150 percent of rated current for THN 15-WI single output series. Hiccup-mode is a method of operation in a power supply whose purpose is to protect the power supply from being damaged during an over-current fault condition. It also enables the power supply to restart when the fault is removed. One of the problems resulting from over current is that excessive heat may be generated in power devices; especially MOSFET and Shottky diodes and the temperature of those devices may exceed their specified limits. A protection mechanism has to be used to prevent those power devices from being damaged.

Output Over Voltage Protection

The output over-voltage protection consists of a Zener diode that monitors the output voltage on the feedback loop. If the voltage on the output terminals exceeds the over-voltage protection threshold, then the Zener diode will send a current signal to the control IC to limiting the output voltage.

Output Voltage Adjustment

Output voltage set point adjustment allows the user to increase or decrease the output voltage set point of a module. This is accomplished by connecting an external resistor between the TRIM pin and either the +V_{out} or -V_{out} pins. With an external resistor between the TRIM and -V_{out} pin, the output voltage set point increases. With an external resistor between the TRIM and +V_{out} pin, the output voltage set point decreases.

- Trim up equation

$$RT1 = \left[\frac{G \times L}{(Vo, up - L - K)} - H \right] \Omega$$

- Trim down equation

$$RT2 = \left[\frac{(Vo, down - L) \times G}{(Vo - Vo, down)} - H \right] \Omega$$

- Trim constants

Module	G	H	K	L
THN 15-xx10WI	5110	2050	0.8	2.5
THN 15-xx11WI	5110	2050	2.5	2.5
THN 15-xx12WI	10000	5110	9.5	2.5
THN 15-xx13WI	10000	5110	12.5	2.5

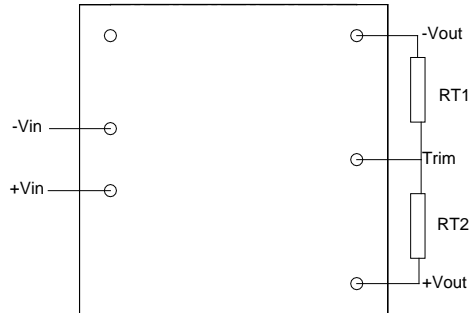

TRIM TABLE

THN 15-xx10WI

Trim up (%)	1	2	3	4	5	6	7	8	9	10
V _{OUT} (Volts) =	3.333	3.366	3.399	3.432	3.465	3.498	3.531	3.564	3.597	3.630
R _{T1} (KΩ) =	385.071	191.511	126.990	94.730	75.374	62.470	53.253	46.340	40.963	36.662
Trim down (%)	1	2	3	4	5	6	7	8	9	10
V _{OUT} (Volts) =	3.267	3.234	3.201	3.168	3.135	3.102	3.069	3.036	3.003	2.970
R _{T2} (KΩ) =	116.719	54.779	34.133	23.810	17.616	13.486	10.537	8.325	6.604	5.228

THN 15-xx11WI

Trim up (%)	1	2	3	4	5	6	7	8	9	10
V _{OUT} (Volts) =	5.050	5.100	5.150	5.200	5.250	5.300	5.350	5.400	5.450	5.500
R _{T1} (KΩ) =	253.450	125.700	83.117	61.825	49.050	40.533	34.450	29.888	26.339	23.500
Trim down (%)	1	2	3	4	5	6	7	8	9	10
V _{OUT} (Volts) =	4.950	4.900	4.850	4.800	4.750	4.700	4.650	4.600	4.550	4.500
R _{T2} (KΩ) =	248.340	120.590	78.007	56.715	43.940	35.423	29.340	24.778	21.229	18.390

THN 15-xx12WI

Trim up (%)	1	2	3	4	5	6	7	8	9	10
V _{OUT} (Volts) =	12.120	12.240	12.360	12.480	12.600	12.720	12.840	12.960	13.080	13.200
R _{T1} (KΩ) =	203.223	99.057	64.334	46.973	36.557	29.612	24.652	20.932	18.038	15.723
Trim down (%)	1	2	3	4	5	6	7	8	9	10
V _{OUT} (Volts) =	11.880	11.760	11.640	11.520	11.400	11.280	11.160	11.040	10.920	10.800
R _{T2} (KΩ) =	776.557	380.723	248.779	182.807	143.223	116.834	97.985	83.848	72.853	64.057

THN 15-xx13WI

Trim up (%)	1	2	3	4	5	6	7	8	9	10
V _{OUT} (Volts) =	15.150	15.300	15.450	15.600	15.750	15.900	16.050	16.200	16.350	16.500
R _{T1} (KΩ) =	161.557	78.223	50.446	36.557	28.223	22.668	18.700	15.723	13.409	11.557
Trim down (%)	1	2	3	4	5	6	7	8	9	10
V _{OUT} (Volts) =	14.850	14.700	14.550	14.400	14.250	14.100	13.950	13.800	13.650	13.500
R _{T2} (KΩ) =	818.223	401.557	262.668	193.223	151.557	123.779	103.938	89.057	77.483	68.223

Short Circuitry Protection

Continuous, hiccup and auto-recovery mode.
 During short circuit, converter still shut down. The average current during this condition will be very low and the device can be safety in this condition.

Thermal Consideration

The power module operates in a variety of thermal environments. However, sufficient cooling should be provided to help ensure reliable operation of the unit. Heat is removed by conduction, convection, and radiation to the surrounding Environment. Proper cooling can be verified by measuring the point as the figure below. The temperature at this location should not exceed 105°C. When Operating, adequate cooling must be provided to maintain the test point temperature at or below 105°C. Although the maximum point Temperature of the power modules is 105°C, you can limit this Temperature to a lower value for extremely high reliability.

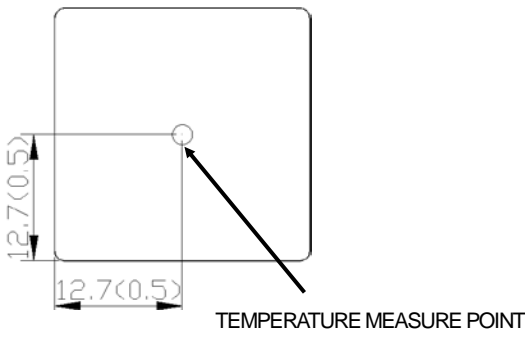

Heat Sink Consideration

Equip heat-sink THN-HS1 for lower temperature and higher reliability of the module. Considering space and air-flow is the way to choose which heat-sink is needed.

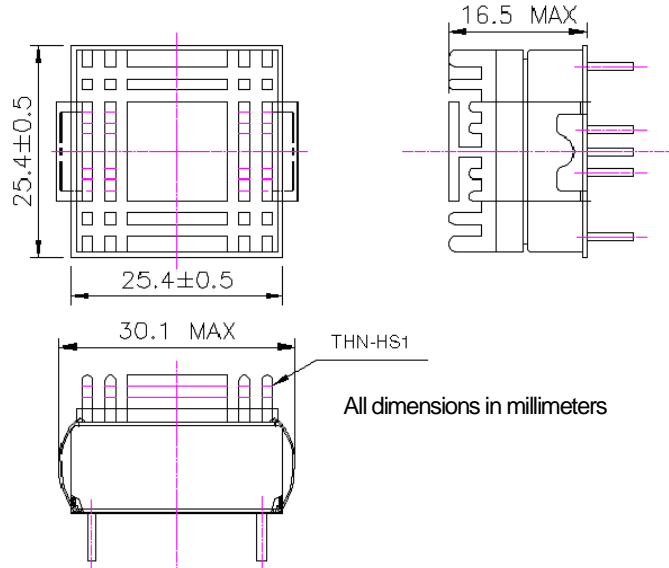

Remote ON/OFF Control

The Remote ON/OFF Pin is controlled DC/DC power module to turn on and off; the user must use a switch to control the logic voltage high or low level of the pin referenced to $-V_{in}$. The switch can be open collector transistor, FET and Photo-Couple. The switch must be capable of sinking up to 1 mA at low-level logic Voltage. High-level logic of the ON/OFF signal maximum voltage is allowable leakage current of the switch at 15V is $50\mu A$.

Remote ON/OFF Implementation Circuits

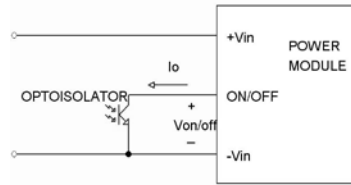

Isolated-Closure Remote ON/OFF

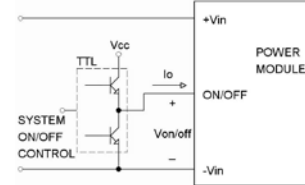

Level Control Using TTL Output

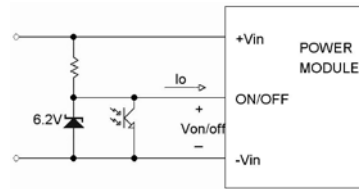

Level Control Using Line Voltage

The Positive logic structure turned on of the DC/DC module when the ON/OFF pin is at high-level logic and low-level logic is turned off it.

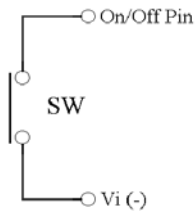

THN 15-WI module is turned off at Low-level logic

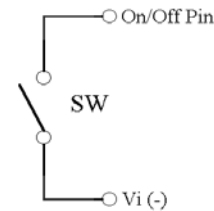

THN 15-WI module is turned on at High-level logic

Mechanical Data

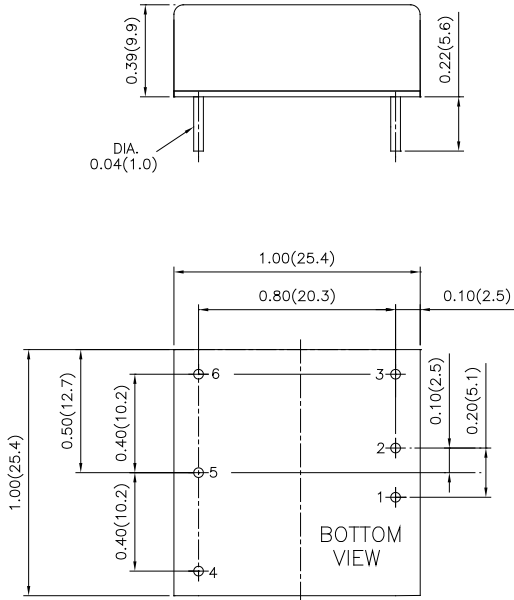

PIN CONNECTION		
PIN	Single Output	Dual Output
1	+ INPUT	+ INPUT
2	- INPUT	- INPUT
3	ON/OFF	ON/OFF
4	+VOUT	+VOUT
5	TRIM	Com
6	-VOUT	-VOUT

1. All dimensions in inches (mm)
2. Tolerance : x.xx ±0.02 (x.x ±0.5)
x.xxx ±0.010 (x.xx ±0.25)
3. Pin pitch tolerance ±0.014 (0.35)

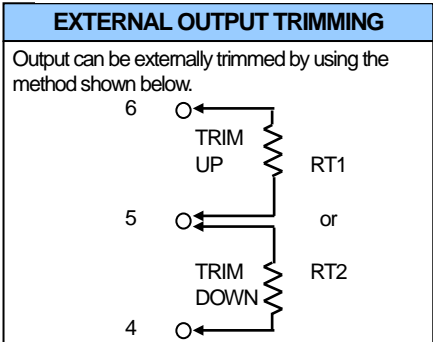

Recommended Pad Layout

Recommended pad layout for DIP type

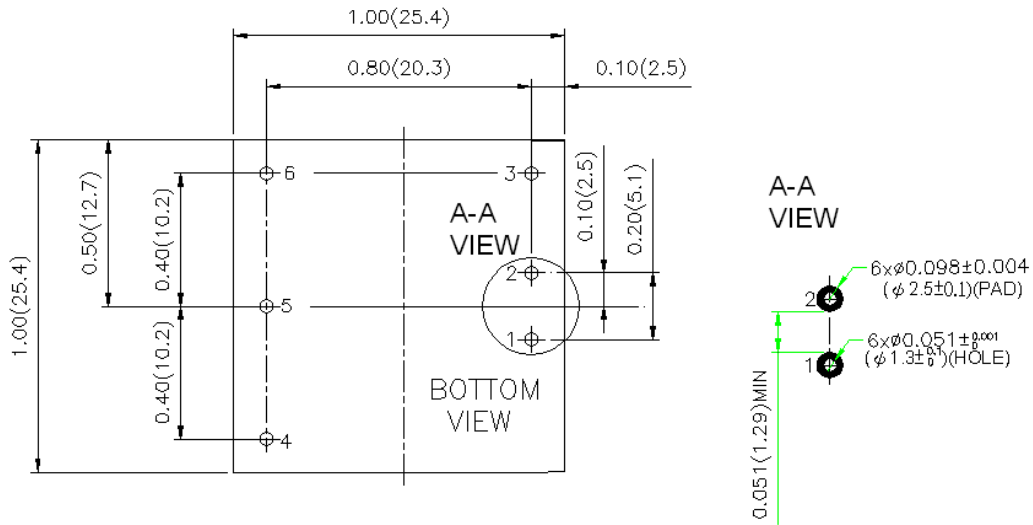

1. All dimensions in inches(mm)
2. Tolerance : x.xx ±0.02 (x.x ±0.5)
x.xxx ±0.010 (x.xx ±0.25)
3. Pin pitch tolerance ±0.014 (0.35)

Soldering and Reflow Considerations

Lead free wave solder profile for DIP type

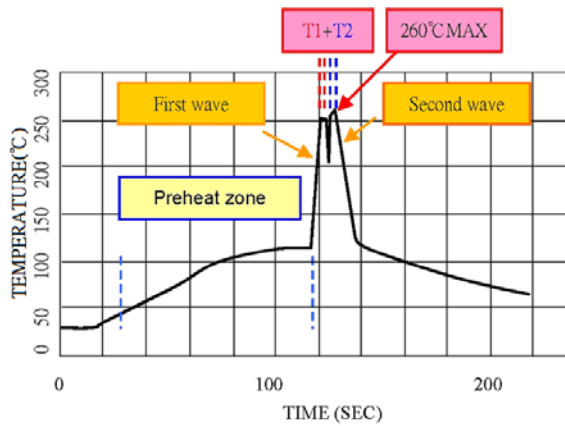

Zone	Reference Parameter.
Preheat zone	Rise temp. speed: 3°C/sec max. Preheat temp. 100~130°C
Actual heating	Peak temp.: 250~260°C Peak time (T1+T2 time): 4~6 sec

Packaging Information

Packaging information for DIP type

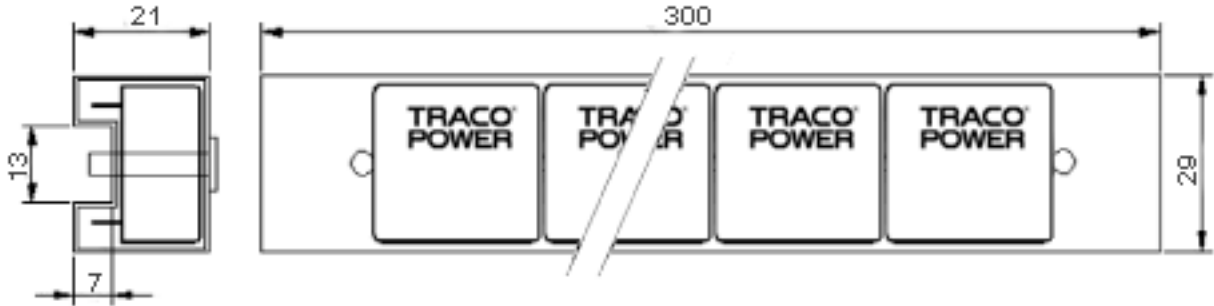

Part Number Structure

THN 15 - 24 11WI

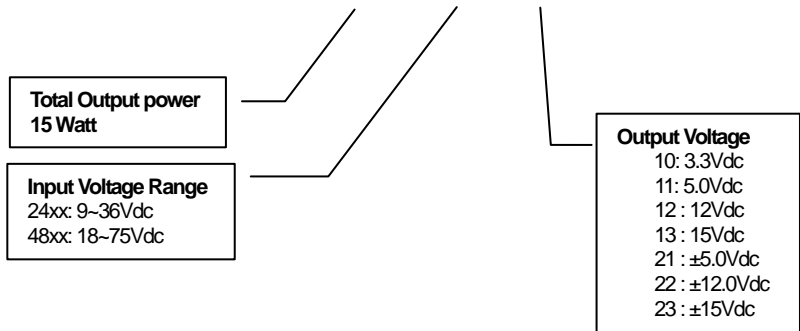

Model Number	Input Range	Output Voltage	Output Current	Input Current	Efficiency ⁽²⁾ (%)
			Full Load	Full Load ⁽¹⁾	
THN 15-2410WI	9 - 36 VDC	3.3 VDC	4000mA	688mA	86
THN 15-2411WI	9 - 36 VDC	5.0 VDC	3000mA	782mA	84
THN 15-2412WI	9 - 36 VDC	12.0 VDC	1300mA	803mA	86
THN 15-2413WI	9 - 36 VDC	15.0 VDC	1000mA	772mA	85
THN 15-2421WI	9 - 36 VDC	±5.0 VDC	±1500mA	722mA	85
THN 15-2422WI	9 - 36 VDC	±12.0 VDC	±625mA	753mA	87
THN 15-2423WI	9 - 36 VDC	±15.0 VDC	±500mA	744mA	88
THN 15-4810WI	18 - 75 VDC	3.3 VDC	4000mA	336mA	86
THN 15-4811WI	18 - 75 VDC	5.0 VDC	3000mA	382mA	86
THN 15-4812WI	18 - 75 VDC	12.0 VDC	1300mA	392mA	87
THN 15-4813WI	18 - 75 VDC	15.0 VDC	1000mA	377mA	87
THN 15-4821WI	18 - 75 VDC	±5.0 VDC	±1500mA	386mA	85
THN 15-4822WI	18 - 75 VDC	±12.0 VDC	±625mA	382mA	86
THN 15-4823WI	18 - 75 VDC	±15.0 VDC	±500mA	377mA	87

Note 1. Maximum value at nominal input voltage and full load.
 Note 2. Typical value at nominal input voltage and full load.

Safety and Installation Instruction

Fusing Consideration

Caution: This power module is not internally fused. An input line fuse must always be used.

This encapsulated power module can be used in a wide variety of applications, ranging from simple stand-alone operation to an integrated part of sophisticated power architecture. To maximum flexibility, internal fusing is not included; however, to achieve maximum safety and system protection, always use an input line fuse. The safety agencies require a normal-blow fuse with maximum rating of 3A for THN 15-24xxWI modules and 1.5A for THN 15-48xxWI modules. Based on the information provided in this data sheet on Inrush energy and maximum DC input current; the same type of fuse with lower rating can be used. Refer to the fuse manufacturer's data for further information.

MTBF and Reliability

The MTBF of THN 15-WI SERIES of DC/DC converters has been calculated using

Bellcore TR-NWT-000332 Case I: 50% stress, Operating Temperature at 40°C (Ground fixed and controlled environment). The resulting figure for MTBF is 1'330'000 hours.

MIL-HDBK 217F NOTICE2 FULL LOAD, Operating Temperature at 25°C. The resulting figure for MTBF is 563'000 hours.