

DATA SHEET

EP10

EP cores and accessories

Product specification
Supersedes data of November 1997
File under Ferrite Ceramics, MA01

1999 Dec 23

EP cores and accessories

EP10

CORE SETS

Effective core parameters

SYMBOL	PARAMETER	VALUE	UNIT
$\Sigma(I/A)$	core factor (C1)	1.70	mm ⁻¹
V_e	effective volume	215	mm ³
l_e	effective length	19.3	mm
A_e	effective area	11.3	mm ²
A_{min}	minimum area	8.55	mm ²
m	mass of core set	≈1.1	g

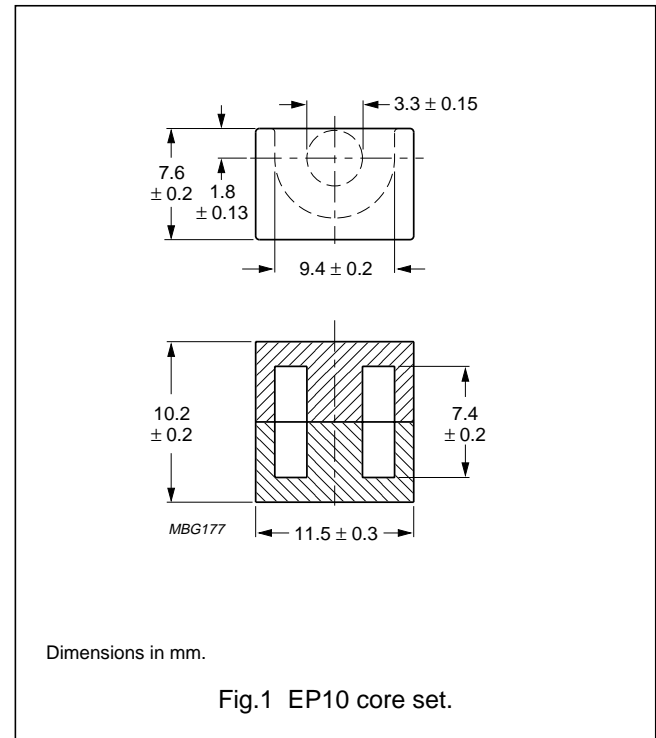



Core sets for general purpose transformers and power applications

Clamping force for A_L measurements, 30 ± 10 N.

GRADE	A_L (nH)	μ_e	AIR GAP (μm)	TYPE NUMBER
3C81	25 ±3%	≈34	≈870	EP10-3C81-E25
	40 ±3%	≈54	≈480	EP10-3C81-A40
	63 ±3%	≈85	≈280	EP10-3C81-A63
	100 ±3%	≈135	≈160	EP10-3C81-A100
	160 ±5%	≈216	≈90	EP10-3C81-A160
	≥900	≥1210	≈0	EP10-3C81
3C90	25 ±3%	≈34	≈870	EP10-3C90-E25
	40 ±3%	≈54	≈480	EP10-3C90-A40
	63 ±3%	≈85	≈280	EP10-3C90-A63
	100 ±3%	≈135	≈160	EP10-3C90-A100
	160 ±5%	≈216	≈90	EP10-3C90-A160
	1140 ±25%	≈1530	≈0	EP10-3C90
3C91 	≥900	≥1210	≈0	EP10-3C91



EP cores and accessories

EP10

GRADE	A_L (nH)	μ_e	AIR GAP (μm)	TYPE NUMBER
3C94 	25 \pm 3%	\approx 34	\approx 870	EP10-3C94-E25
	40 \pm 3%	\approx 54	\approx 480	EP10-3C94-A40
	63 \pm 3%	\approx 85	\approx 280	EP10-3C94-A63
	100 \pm 3%	\approx 135	\approx 160	EP10-3C94-A100
	160 \pm 5%	\approx 216	\approx 90	EP10-3C94-A160
	1140 \pm 25%	\approx 1530	\approx 0	EP10-3C94
3C96 	1025 \pm 25%	\approx 1380	\approx 0	EP10-3C96
3D3	40 \pm 3%	\approx 54	\approx 480	EP10-3D3-A40
	63 \pm 3%	\approx 85	\approx 280	EP10-3D3-A63
	100 \pm 3%	\approx 135	\approx 160	EP10-3D3-A100
	470 \pm 5%	\approx 635	\approx 0	EP10-3D3-A470
3F3	25 \pm 3%	\approx 34	\approx 870	EP10-3F3-E25
	40 \pm 3%	\approx 54	\approx 480	EP10-3F3-A40
	63 \pm 3%	\approx 85	\approx 280	EP10-3F3-A63
	100 \pm 3%	\approx 135	\approx 160	EP10-3F3-A100
	160 \pm 5%	\approx 216	\approx 90	EP10-3F3-A160
	1000 \pm 25%	\approx 1350	\approx 0	EP10-3F3
3F35 	800 \pm 25%	\approx 1080	\approx 0	EP10-3F35
3F4	63 \pm 3%	\approx 85	\approx 280	EP10-3F4-A63
	100 \pm 3%	\approx 135	\approx 160	EP10-3F4-A100
	160 \pm 5%	\approx 216	\approx 90	EP10-3F4-A160
	560 \pm 25%	\approx 760	\approx 0	EP10-3F4
3H3	40 \pm 3%	\approx 54	\approx 480	EP10-3H3-A40
	63 \pm 3%	\approx 85	\approx 280	EP10-3H3-A63
	100 \pm 3%	\approx 135	\approx 160	EP10-3H3-A100
	160 \pm 5%	\approx 216	\approx 90	EP10-3H3-A160
	1025 \pm 25%	\approx 1390	\approx 0	EP10-3H3

Core sets of high permeability grades

Clamping force for A_L measurements, 30 \pm 10 N.

GRADE	A_L (nH)	μ_e	AIR GAP (μm)	TYPE NUMBER
3E1 	2000 +30/-20%	\approx 2700	\approx 0	EP10-3E1
3E4 	3200 +40/-30%	\approx 4300	\approx 0	EP10-3E4
3E27	\geq 2500	\geq 3370	\approx 0	EP10-3E27
3E5	4800 +40/-30%	\approx 6500	\approx 0	EP10-3E5
3E6	6900 +40/-30%	\approx 9340	\approx 0	EP10-3E6

EP cores and accessories

EP10

Properties of core sets under power conditions

GRADE	B (mT) at	CORE LOSS (W) at			
	H = 250 A/m; f = 25 kHz; T = 100 °C	f = 25 kHz; \hat{B} = 200 mT; T = 100 °C	f = 100 kHz; \hat{B} = 100 mT; T = 100 °C	f = 100 kHz; \hat{B} = 200 mT; T = 100 °C	f = 400 kHz; \hat{B} = 50 mT; T = 100 °C
3C81	≥315	≤0.043	–	–	–
3C90	≥320	≤0.024	≈0.024	–	–
3C91	≥315	≈0.022	≈0.022	–	–
3C94	≥320	–	≤0.019	≈0.093	≈0.043
3C96	≥320	–	≈0.014	≈0.065	≈0.030
3F35	≥300	–	–	–	≈0.022
3F3	≥315	–	≤0.025	–	≤0.045
3F4	≥250	–	–	–	–

Properties of core sets under power conditions (continued)

GRADE	B (mT) at	CORE LOSS (W) at			
	H = 250 A/m; f = 25 kHz; T = 100 °C	f = 500 kHz; \hat{B} = 50 mT; T = 100 °C	f = 500 kHz; \hat{B} = 100 mT; T = 100 °C	f = 1 MHz; \hat{B} = 30 mT; T = 100 °C	f = 3 MHz; \hat{B} = 10 mT; T = 100 °C
3C81	≥315	–	–	–	–
3C90	≥320	–	–	–	–
3C91	≥315	–	–	–	–
3C94	≥320	–	–	–	–
3C96	≥320	–	–	–	–
3F35	≥300	≈0.035	≈0.26	–	–
3F3	≥315	–	–	–	–
3F4	≥250	–	–	≤0.043	≤0.069

EP cores and accessories

EP10

COIL FORMER

General data CSH-EP10-1S-8P

PARAMETER	SPECIFICATION
Coil former material	phenolformaldehyde (PF), glass-reinforced, flame retardant in accordance with "UL 94V-0"; UL file number E46770(M)
Pin material	copper clad steel, tin-lead alloy (SnPb) plated
Maximum operating temperature	180 °C, "IEC 60085", class H
Resistance to soldering heat	"IEC 60068-2-20", Part 2, Test Tb, method 1B, 350 °C, 3.5 s
Solderability	"IEC 60068-2-20", Part 2, Test Ta, method 1, 235 °C, 2 s

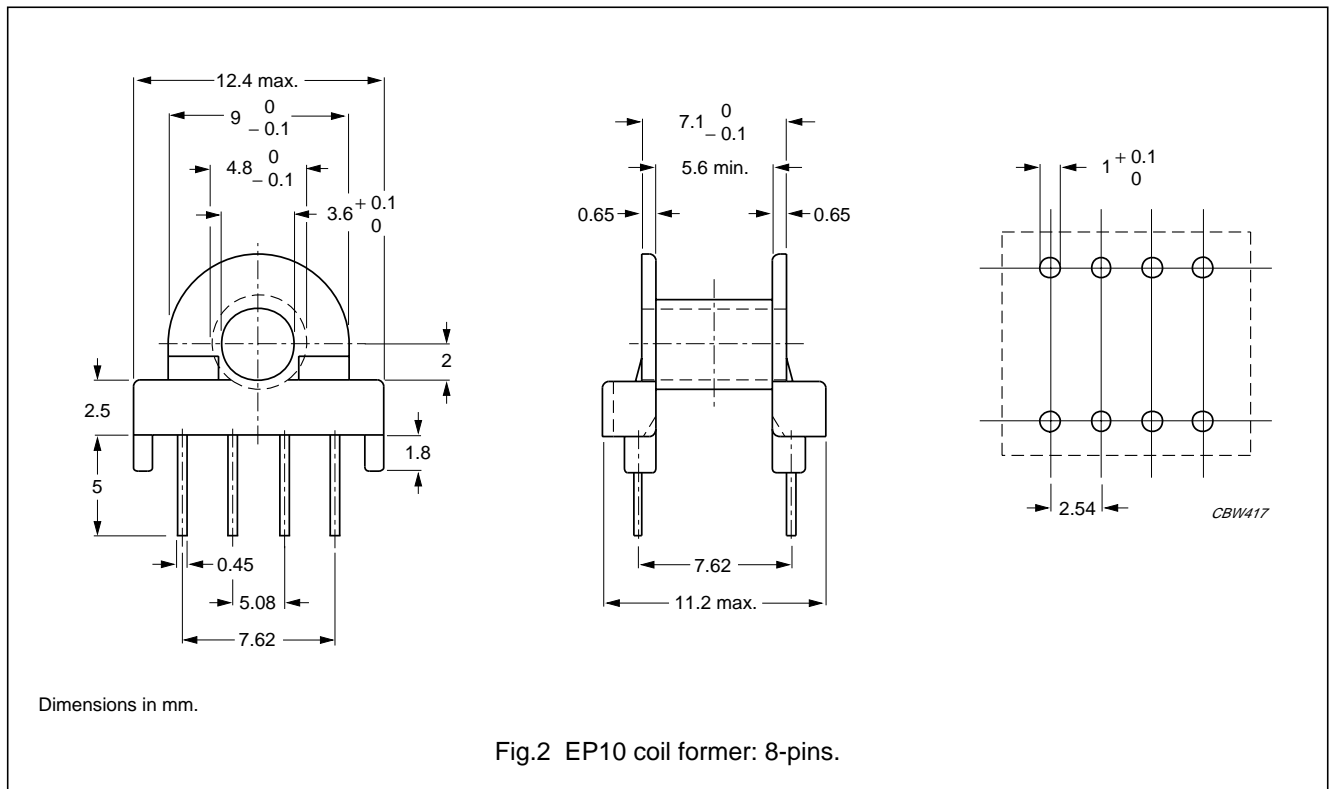

Winding data for 8-pins EP10 coil former

NUMBER OF SECTIONS	WINDING AREA (mm ²)	MINIMUM WINDING WIDTH (mm)	AVERAGE LENGTH OF TURN (mm)	TYPE NUMBER
1	11.4	5.6	21.5	CSH-EP10-1S-8P

EP cores and accessories

EP10

General data CSH-EP10-1S-8P-A

PARAMETER	SPECIFICATION
Coil former material	phenolformaldehyde (PF), glass-reinforced, flame retardant in accordance with "UL 94V-0"; UL file number E46770(M)
Pin material	copper-tin alloy (CuSn), tin-lead alloy (SnPb) plated
Maximum operating temperature	180 °C, "IEC 60085", class H
Resistance to soldering heat	"IEC 60068-2-20", Part 2, Test Tb, method 1B, 350 °C, 3.5 s
Solderability	"IEC 60068-2-20", Part 2, Test Ta, method 1, 235 °C, 2 s

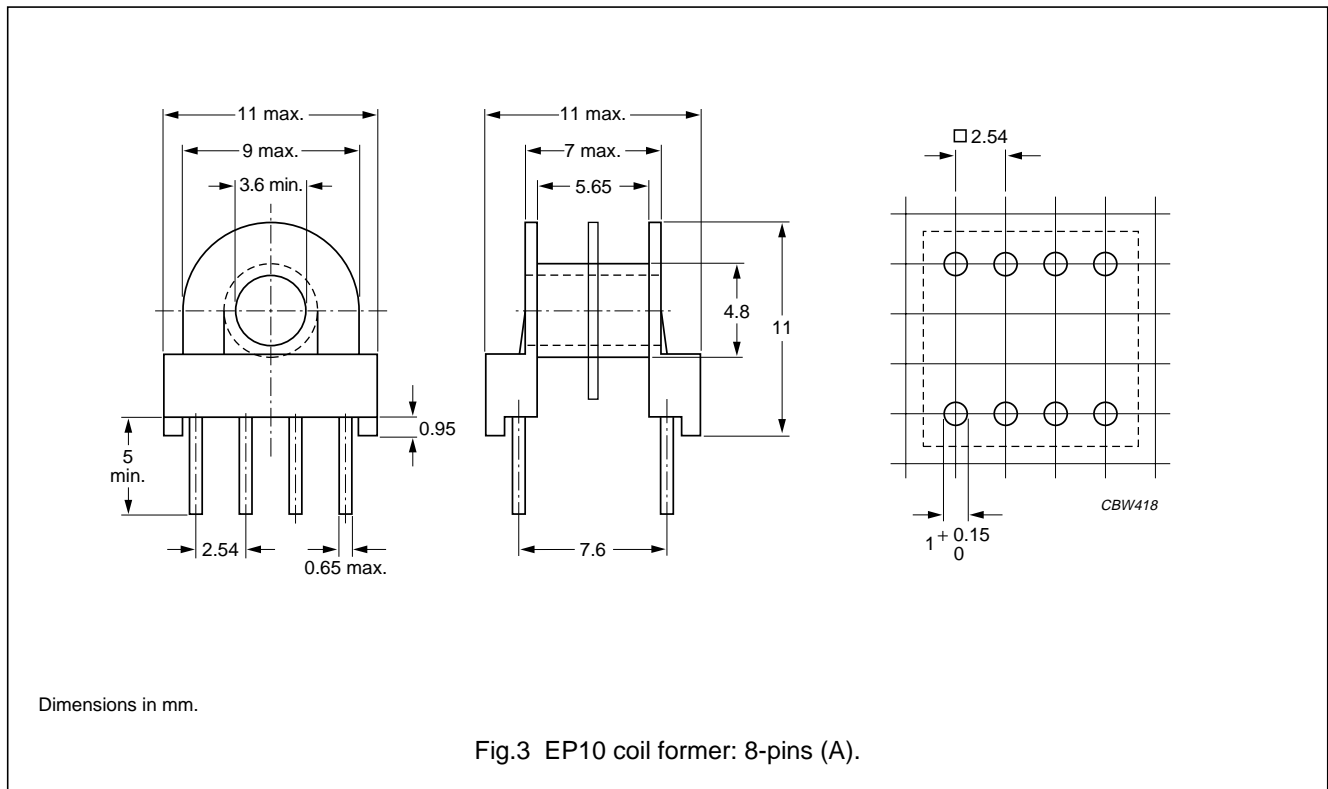

Winding data for 8-pins EP10 coil former

NUMBER OF SECTIONS	MINIMUM WINDING AREA (mm ²)	NOMINAL WINDING WIDTH (mm)	AVERAGE LENGTH OF TURN (mm)	TYPE NUMBER
2	2 × 4.77	2 × 2.6	21.5	CSH-EP10-2S-8P-A

EP cores and accessories

EP10

General data CSH-EP10-2S-8P

PARAMETER	SPECIFICATION
Coil former material	phenolformaldehyde (PF), glass-reinforced, flame retardant in accordance with "UL 94V-0"; UL file number E41429 (M)
Pin material	copper-clad steel, tin-lead alloy (SnPb) plated
Maximum operating temperature	155 °C, "IEC 60085", class F
Resistance to soldering heat	"IEC 60068-2-20", Part 2, Test Tb, method 1B, 350 °C, 3.5 s
Solderability	"IEC 60068-2-20", Part 2, Test Ta, method 1, 235 °C, 2 s

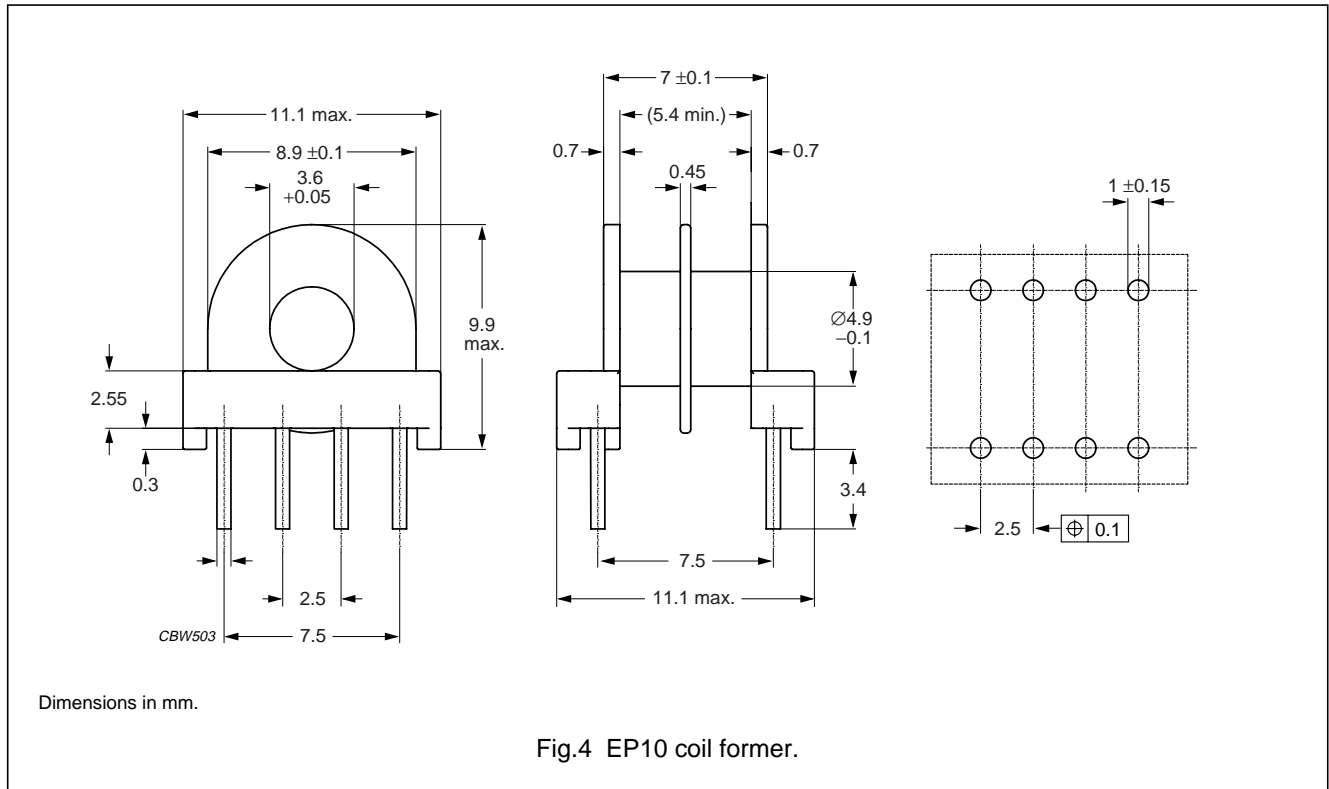

Winding data for EP10 coil former

NUMBER OF SECTIONS	MINIMUM WINDING AREA (mm ²)	NOMINAL WINDING WIDTH (mm)	AVERAGE LENGTH OF TURN (mm)	TYPE NUMBER
2	9.6	5.4	21.6	CSH-EP10-2S-8P

EP cores and accessories

EP10

General data CSHS-EP10-1S-8P-T

PARAMETER	SPECIFICATION
Coil former material	phenolformaldehyde (PF), glass-reinforced, flame retardant in accordance with "UL 94V-0"; UL file number E41429 (M)
Pin material	copper-clad steel, tin-lead alloy (SnPb) plated
Maximum operating temperature	155 °C, "IEC 60085", class F
Resistance to soldering heat	"IEC 60068-2-20", Part 2, Test Tb, method 1B, 350 °C, 3.5 s
Solderability	"IEC 60068-2-20", Part 2, Test Ta, method 1, 235 °C, 2 s

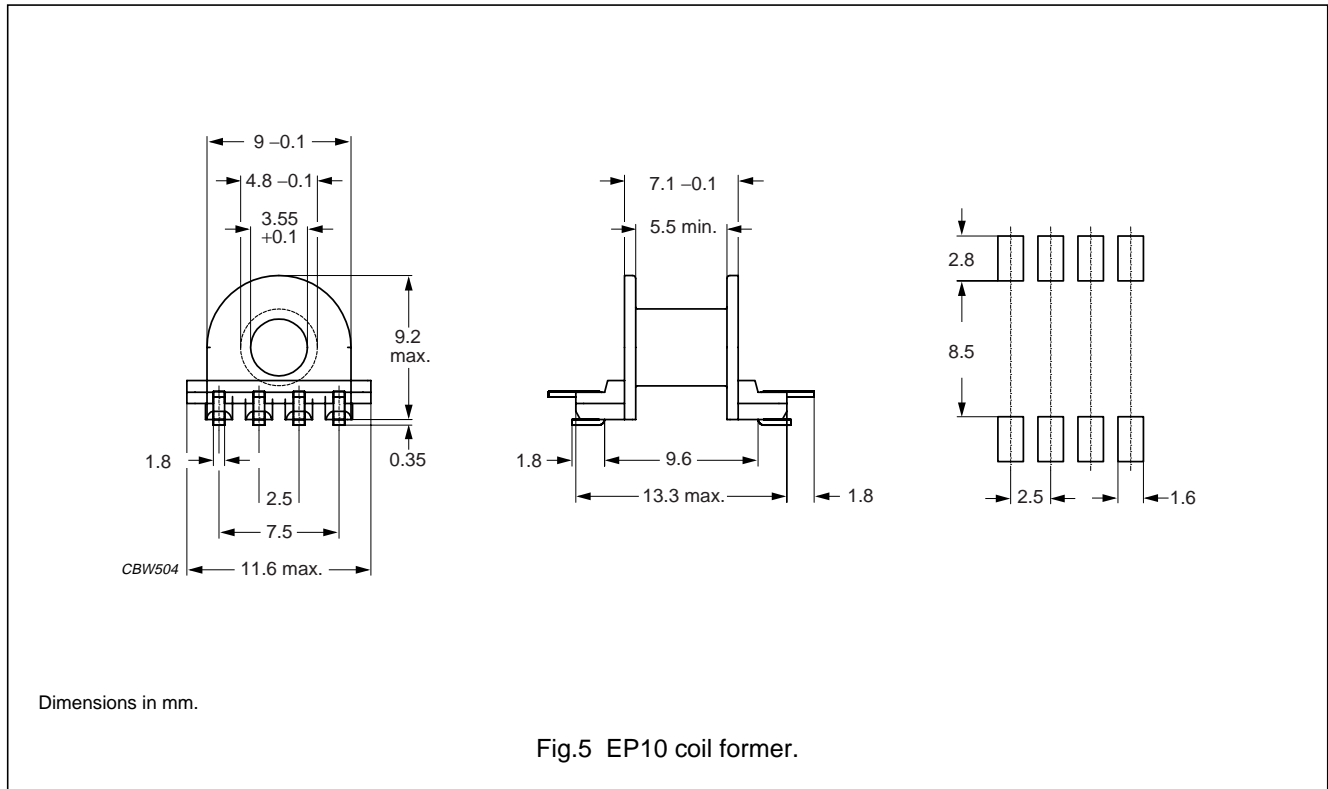

Winding data for EP10 coil former

NUMBER OF SECTIONS	MINIMUM WINDING AREA (mm ²)	NOMINAL WINDING WIDTH (mm)	AVERAGE LENGTH OF TURN (mm)	TYPE NUMBER
1	11.3	5.5	21.5	CSHS-EP10-1S-8P-T

EP cores and accessories

EP10

MOUNTING PARTS

General data

ITEM	REMARKS	FIGURE	TYPE NUMBER
Clasp	copper-nickel-zinc alloy (nickel silver)	6	CLA-EP10
Spring	copper-nickel-zinc alloy (nickel silver)	7	SPR-EP10
Clip	stainless steel (CrNi); clamping force ≈ 27 N	8	CLI-EP10

