

Agilent U3606B

Increase test efficiency with the next generation one-box supply-and-measure solution

Application Note

Introduction

In today's semiconductor market, instruments such as voltmeters, ammeters, ohmmeters, multimeters, and AC/DC power sources are commonly used for testing. Engineers and technicians use these instruments to test transistors, capacitors, diodes, and many other semiconductor parts and devices.

The Agilent U3606B Multimeter | DC Power Supply represents a new generation of instruments, providing 5½ digit display and 30 W DC power supply functions. It is specifically built for applications that require multimeter and DC power supply concurrently while elevating performance to the next level. Combining two instruments into one will free up your work space on the test rack and bench, while lowering cost. The combined approach also allows a single connection, rather than two separate connections from the multimeter and DC power supply to your PC. Hence, when programming remotely, the possibility of connection errors are lower.

Since a digital multimeter and a DC power supply are required to carry out tests on a Zener Diode and a DC-to-DC converter, the U3606B is the best choice for this application.



Diode Test

How do engineers and technicians carry out test on a diode? They use a digital multimeter with a DIODE test function. The test is relatively easy. First, users can use the probes from a digital multimeter to connect both the anode and cathode of a diode, and check if the condition of the diode is forward-biased or reverse-biased.

When the diode is forward-biased, the digital multimeter will display an approximate value: from 0.5 to 0.8 V (see Figure 1). If the diode is reverse-biased, an open-circuit sign will be displayed on the digital multimeter. That means there is no connection found (see Figure 2).

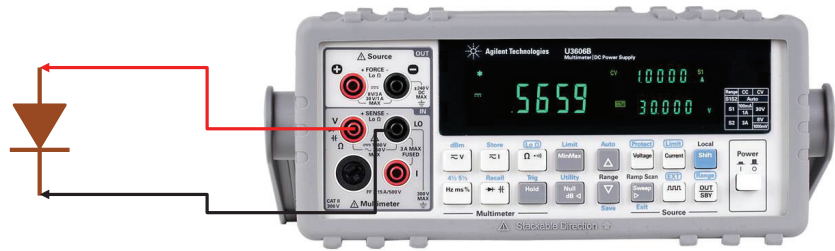

Figure 1. Forward-biased condition in a diode



Figure 2. Reverse-biased condition in a diode

Zener Diode Test

A Zener diode exhibits different characteristic than a conventional diode. The Zener diode is designed to reliably and safely allow a breakdown phenomenon, so that it can be used in reverse to maintain a fixed voltage across its terminal. Besides, the Zener diode allows current to flow not only in the forward-biased, but also in the reverse-biased condition when the voltage is above a certain value.

Therefore, testing on Zener diodes must be carried out differently than with conventional diodes. See Figure 3 for the Zener diode I-V characteristic with a 12 V breakdown voltage. To acquire the Zener voltage level, a digital multimeter and a DC power supply are required (see Figure 4). The DC power supply is used to adjust the input voltage to a suitable value for the Zener diode under test, while the digital multimeter is used to measure the breakdown voltage. The purpose of a resistor placed between the DC power supply and the Zener diode is to limit the current through the Zener diode. No current will flow until the voltage across the Zener diode is

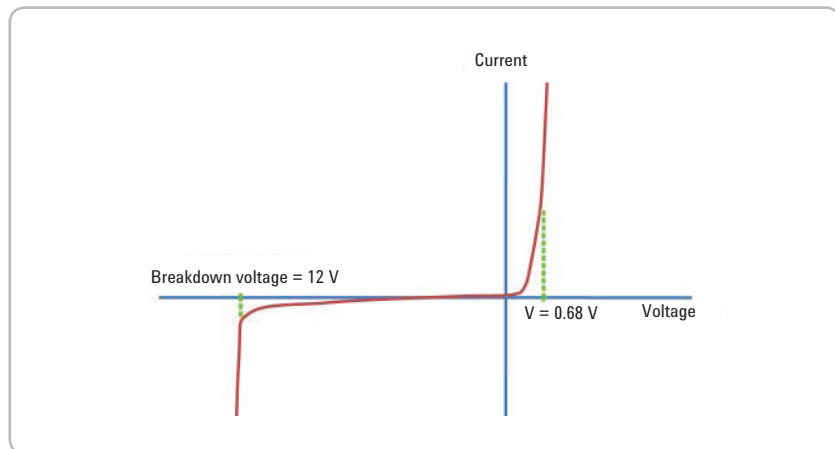

Figure 3. I-V characteristic of a breakdown voltage in a 12 V Zener diode

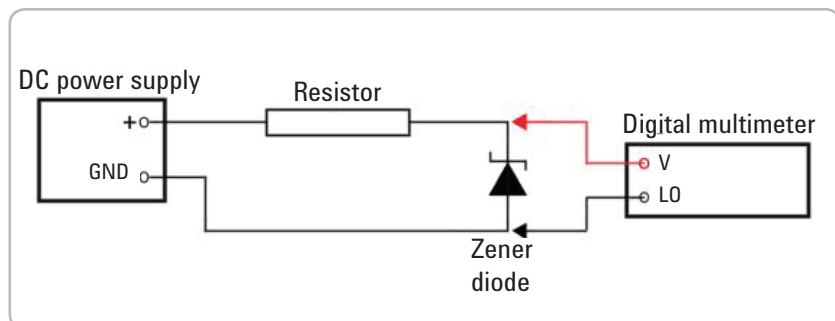

Figure 4. Zener diode test using a digital multimeter and a DC power supply

equal to the Zener voltage. If the diode is connected in an opposite direction (reverse-biased), current will flow at low voltage: from 0.5 to 0.8 V. The Zener diode is defective when current flows at low voltage in both directions.

Zener Diode Test with the U3606B

The U3606B Multimeter | DC Power Supply is a two-in-one instrument which has the functions of both multimeter and DC power supply. Thus, the U3606B is a better one-box supply-and-measure solution for a Zener diode test. Figure 5 shows the U3606B providing a voltage source to a Zener diode with a resistor in between. There are several advantages in using the U3606B to carry out tests on the Zener diode, including ease of operation, space and cost savings, and fewer connectivity problems.

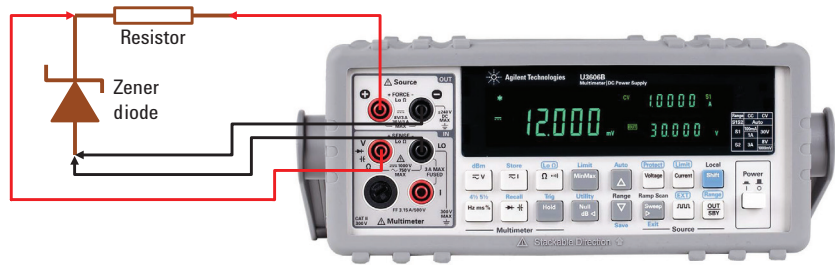

Figure 5. Zener diode test using the U3606B

DC-to-DC Converter Test

A DC-to-DC converter test is another application that requires both a digital multimeter and a DC power supply. The test setup is easy. A DC power supply is connected to the input of a DC-to-DC converter. A digital multimeter is then used to measure the output of the DC-to-DC converter. For example, in testing on a 12 to 5 V DC-to-DC converter, the DC power supply provides a source of 12 V (11.4 to 12.6 V) DC voltage to a DC-to-DC converter. The DC-to-DC converter 5 V output is then measured with the digital multimeter (see Figure 6). A test carried out on the DC-to-DC converter is made even easier by using the U3606B, because only one instrument is required. Similar testing on a Zener diode, using the U3606B in this scenario costs less, saves work space, causes fewer connectivity problem, and is easy to use (see Figure 7).

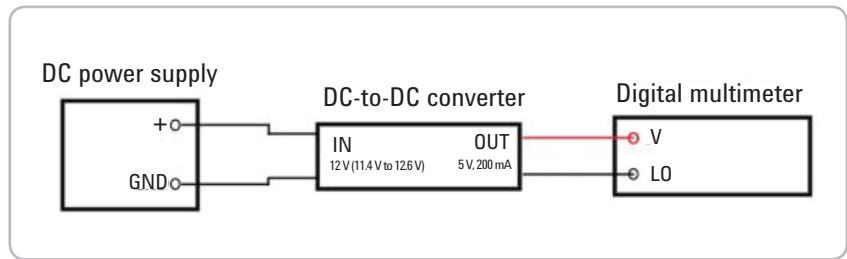

Figure 6. DC-to-DC converter test using a digital multimeter and a DC power supply

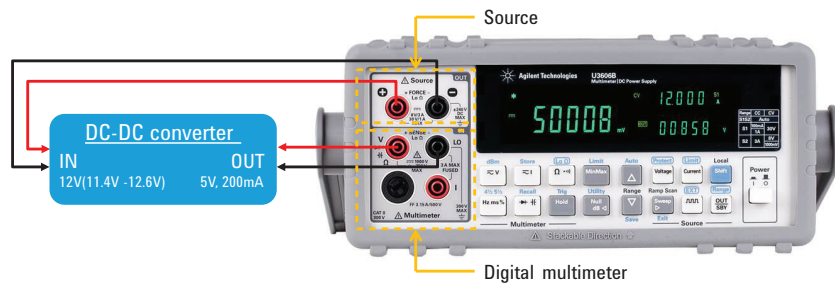

Figure 7. DC-to-DC converter test using the U3606B

Conclusion

The Agilent U3606B Multimeter | DC Power Supply is a remarkable tool that combines both DC digital multimeter and DC power supply. It is specially built for applications that require use of measuring instruments and DC power sources concurrently and independently. The two-in-one instrumentation concept provides ease of use, simpler cable connectivity, and more efficient use of work space, all of which will eventually lead to test efficiency and cost-effectiveness.



myAgilent

www.agilent.com/find/myagilent

A personalized view into the information most relevant to you.



www.axistandard.org

AdvancedTCA® Extensions for Instrumentation and Test (AXIe) is an open standard that extends the AdvancedTCA for general purpose and semiconductor test. Agilent is a founding member of the AXIe consortium.



www.lxistandard.org

LAN eXtensions for Instruments puts the power of Ethernet and the Web inside your test systems. Agilent is a founding member of the LXI consortium.



www.pxisa.org

PCI eXtensions for Instrumentation (PXI) modular instrumentation delivers a rugged, PC-based high-performance measurement and automation system.

Agilent Channel Partners

www.agilent.com/find/channelpartners

Get the best of both worlds: Agilent's measurement expertise and product breadth, combined with channel partner convenience.



Three-Year Warranty

www.agilent.com/find/ThreeYearWarranty

Agilent's combination of product reliability and three-year warranty coverage is another way we help you achieve your business goals: increased confidence in uptime, reduced cost of ownership and greater convenience.



Agilent Advantage Services

www.agilent.com/find/AdvantageServices

Accurate measurements throughout the life of your instruments.



www.agilent.com/quality

www.agilent.com

www.agilent.com/find/hybrid-multimeter

For more information on Agilent Technologies' products, applications or services, please contact your local Agilent office. The complete list is available at: www.agilent.com/find/contactus

Americas

Canada	(877) 894 4414
Brazil	(11) 4197 3600
Mexico	01800 5064 800
United States	(800) 829 4444

Asia Pacific

Australia	1 800 629 485
China	800 810 0189
Hong Kong	800 938 693
India	1 800 112 929
Japan	0120 (421) 345
Korea	080 769 0800
Malaysia	1 800 888 848
Singapore	1 800 375 8100
Taiwan	0800 047 866
Other AP Countries	(65) 375 8100

Europe & Middle East

Belgium	32 (0) 2 404 93 40
Denmark	45 45 80 12 15
Finland	358 (0) 10 855 2100
France	0825 010 700* *0.125 €/minute
Germany	49 (0) 7031 464 6333
Ireland	1890 924 204
Israel	972-3-9288-504/544
Italy	39 02 92 60 8484
Netherlands	31 (0) 20 547 2111
Spain	34 (91) 631 3300
Sweden	0200-88 22 55
United Kingdom	44 (0) 118 927 6201

For other unlisted countries:

www.agilent.com/find/contactus

(BP-3-1-13)

Product specifications and descriptions in this document subject to change without notice.

© Agilent Technologies, Inc. 2009, 2013
Published in USA, August 25, 2013
5990-4064EN



Agilent Technologies