

## Long-distance Detection of Both Ferrous or Non-ferrous Metals





- Same sensing distance for non-ferrous metals, such as aluminum and brass, and ferrous metals.
- Maximum sensing distance of 10 mm.



 Be sure to read *Safety Precautions* on page 5.

## Ordering Information

**Sensors** [Refer to *Dimensions* on page 6.]

Appearance	Sensing distance	Output configuration	Model	
			Operation mode	
			NO	NC
 Shielded	M12  2 mm	DC 3-wire NPN	E2EV-X2C1 2M	E2EV-X2C2 2M
	M18  5 mm		E2EV-X5C1 2M	E2EV-X5C2 2M
	M30  10 mm		E2EV-X10C1 2M	E2EV-X10C2 2M

### Accessories (Order Separately)

[Mounting Brackets](#)

[Protective Covers](#)

[Sputter Protective Covers](#)

Refer to Y92□ for details.

## Ratings and Specifications

Model		E2EV-X2C1 E2EV-X2C2	E2EV-X5C1 E2EV-X5C2	E2EV-X10C1 E2EV-X10C2
<b>Item</b>				
<b>Sensing distance</b>		2mm ±10%	5 mm ±10%	10 mm ±10%
<b>Set distance</b>		0 to 1.4 mm	0 to 3.5 mm	0 to 7 mm
<b>Differential travel</b>		10% max. of sensing distance		
<b>Detectable object</b>		Ferrous metal and non-ferrous metal		
<b>Standard sensing object</b>		Aluminum: 12 × 12 × 1 mm	Aluminum: 18 × 18 × 1 mm	Aluminum: 30 × 30 × 1 mm
<b>Response frequency *</b>		150 Hz	70 Hz	
<b>Power supply voltage (operating voltage range)</b>		12 to 24 VDC (10 to 30 VDC), ripple (p-p): 10% max.		
<b>Current consumption</b>		15 mA max.		
<b>Control output</b>	<b>Load current</b>	NPN open-collector output, 100 mA max. (at 30 VDC)		
	<b>Residual voltage</b>	2 V max. (Load current: 100 mA, Cable length: 2 m)		
<b>Indicators</b>		Detection indicator (red)		
<b>Operation mode (with sensing object approaching)</b>		C1 Models: NO Refer to the timing charts under <i>I/O Circuit Diagrams</i> on page 4 for details. C2 Models: NC		
<b>Protection circuits</b>		Reverse polarity protection, Load short-circuit protection, Surge suppressor		
<b>Ambient temperature range</b>		Operating/Storage: -10 to 55°C (with no icing or condensation)		
<b>Ambient humidity range</b>		Operating/Storage: 35% to 95% (with no condensation)		
<b>Temperature influence</b>		±20% max. of sensing distance at 23°C in the temperature range of -10 to 55°C		
<b>Voltage influence</b>		±2.5% max. of sensing distance at rated voltage in the rated voltage ±15% range		
<b>Insulation resistance</b>		50 MΩ min. (at 500 VDC) between current-carrying parts and case		
<b>Dielectric strength</b>		1,000 VAC, 50/60 Hz for 1 minute between current-carrying parts and case		
<b>Vibration resistance</b>		Destruction: 10 to 55 Hz, 1.5-mm double amplitude for 2 hours each in X, Y, and Z directions		
<b>Shock resistance</b>		Destruction: 1,000 m/s <sup>2</sup> 10 times each in X, Y, and Z directions		
<b>Degree of protection</b>		IEC 60529 IP67, in-house standards: oil-resistant		
<b>Connection method</b>		Pre-wired Models (Standard cable length: 2 m)		
<b>Weight (packed state)</b>		Approx. 120 g	Approx. 140 g	Approx. 190 g
<b>Materials</b>	<b>Case</b>	Nickel-plated brass		
	<b>Sensing surface</b>	Heat-resistant ABS		
	<b>Clamping nuts</b>	Nickel-plated brass		
	<b>Toothed washer</b>	Zinc-plated iron		
<b>Accessories</b>		Instruction manual		

\* The response frequency is an average value. Measurement conditions are as follows: standard sensing object, a distance of twice the standard sensing object, and a set distance for the DC switching section of half the sensing distance.

Engineering Data (Reference Value)

**Sensing Area** (Note: Other non-ferrous metal, such as stainless steel, copper, and brass, have the same characteristics.)

**E2EV-X2C**

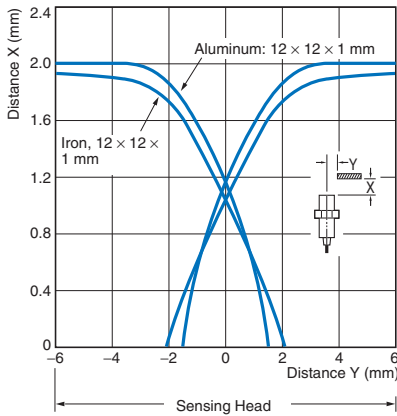

**E2EV-X5C**

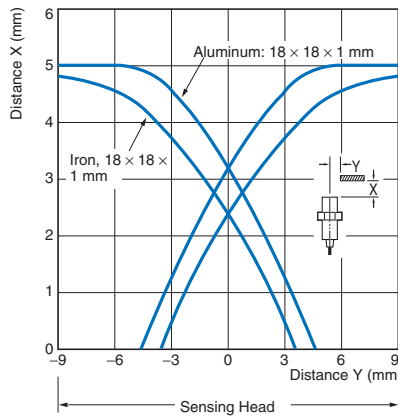

**E2EV-X10C**

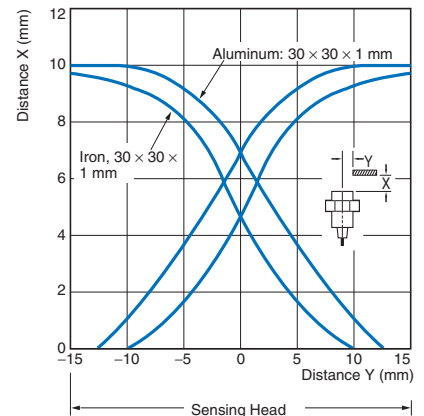

**Influence of Sensing Object Size and Material**

**E2EV-X2C**

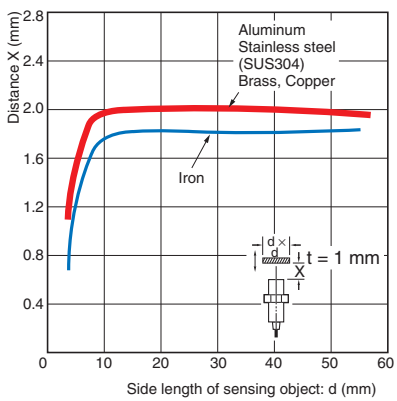

**E2EV-X5C**

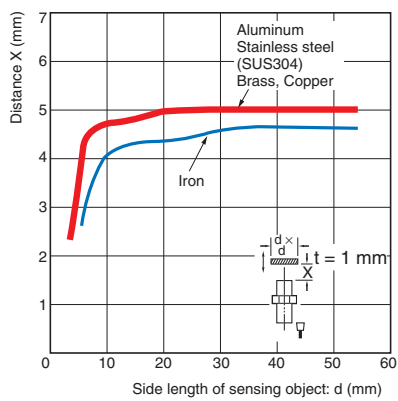

**E2EV-X10C**

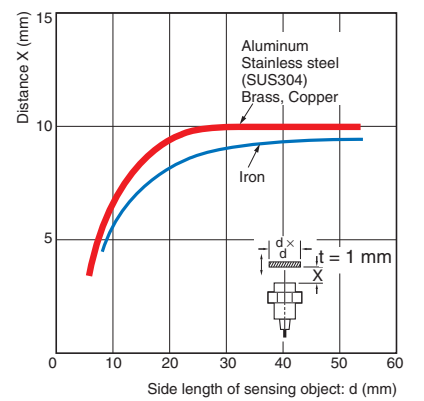

**Residual Output Voltage**

**E2EV**

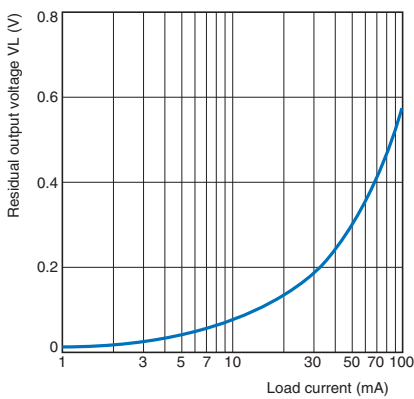

I/O Circuit Diagrams

DC 3-Wire Models

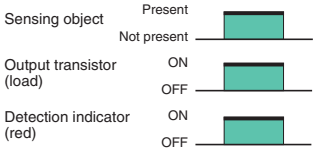
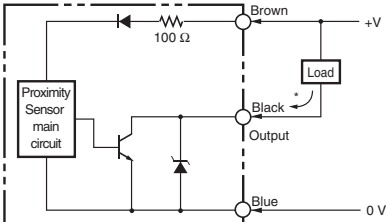
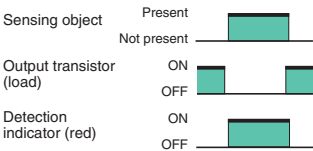
Operation mode	Model	Timing chart	Output circuit
NO	E2EV-X2C1 E2EV-X5C1 E2EV-X10C1		 <p>*Load current: 100 mA max.</p>
NC	E2EV-X2C2 E2EV-X5C2 E2EV-X10C2		

## Safety Precautions

Refer to *Warranty and Limitations of Liability*.

### ⚠ WARNING

This product is not designed or rated for ensuring safety of persons either directly or indirectly. Do not use it for such purposes.



### Precautions for Correct Use

Do not use this product under ambient conditions that exceed the ratings.

#### ● Design

##### Influence of Surrounding Metal

When mounting the Sensor within a metal panel, ensure that the clearances given in the following table are maintained. Failure to maintain these distances may cause deterioration in the performance of the Sensor.

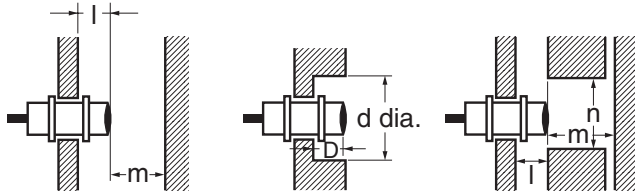

Influence of Surrounding Metal (Unit: mm)

Model	Item	l	d	D	m	n
E2EV-X2C□		0	12	0	8	18
E2EV-X5C□			18		20	27
E2EV-X10C□			30		40	45

##### Mutual Interference

When installing Sensors face-to-face or side-by-side, ensure that the minimum distances given in the following table are maintained.

Mutual Interference (Unit: mm)

Model	Item	A	B
E2EV-X2C□		30	20
E2EV-X5C□		50	35
E2EV-X10C□		100	70

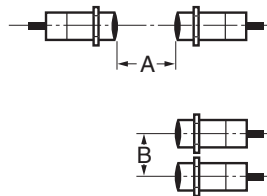

#### ● Mounting

Do not tighten the nut with excessive force. A toothed washer must be used with the nut.

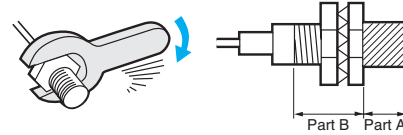

Note: 1. The allowable tightening strength depends on the distance from the edge of the head, as shown in the following table. (A is the distance from the edge of the head. B includes the nut on the head side. If the edge of the nut is in part A, the tightening torque for part A applies instead.)  
2. The following strength assume washers are being used.

Tightening Torque	Part A		Part B
	Dimension (mm)	Torque	Torque
E2EV-X2C□	17	5.9 N·m	9.8 N·m
E2EV-X5C□	22	15 N·m	49 N·m
E2EV-X10C□	26	39 N·m	78 N·m

## Dimensions

### E2EV-X2C□

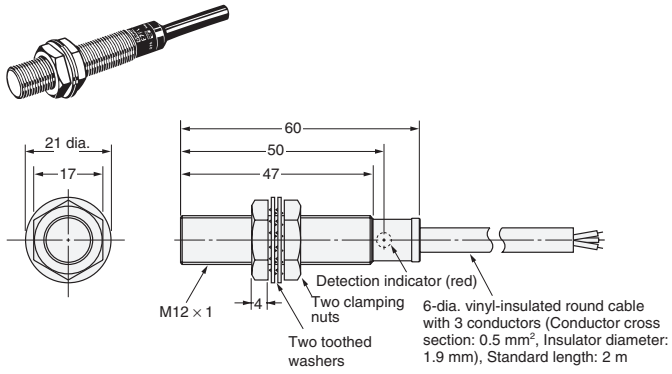

### E2EV-X10C□

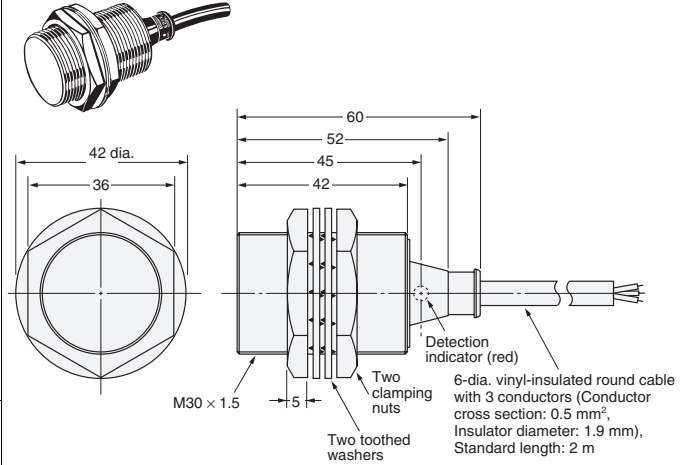

### E2EV-X5C□

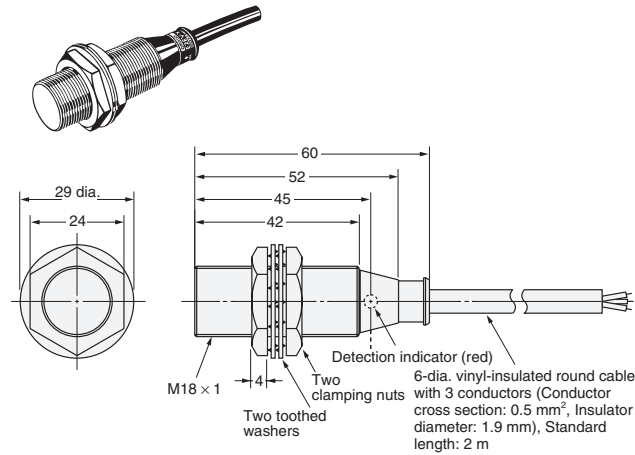

## Mounting Hole Dimensions

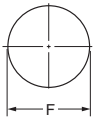

Model	F (mm)
E2EV-X2C□	12.5 <sup>+0.5</sup> <sub>0</sub> dia.
E2EV-X5C□	18.5 <sup>+0.5</sup> <sub>0</sub> dia.
E2EV-X10C□	30.5 <sup>+0.5</sup> <sub>0</sub> dia.

## Terms and Conditions Agreement

### Read and understand this catalog.

Please read and understand this catalog before purchasing the products. Please consult your OMRON representative if you have any questions or comments.

### Warranties.

(a) Exclusive Warranty. Omron's exclusive warranty is that the Products will be free from defects in materials and workmanship for a period of twelve months from the date of sale by Omron (or such other period expressed in writing by Omron). Omron disclaims all other warranties, express or implied.

(b) Limitations. OMRON MAKES NO WARRANTY OR REPRESENTATION, EXPRESS OR IMPLIED, ABOUT NON-INFRINGEMENT, MERCHANTABILITY OR FITNESS FOR A PARTICULAR PURPOSE OF THE PRODUCTS. BUYER ACKNOWLEDGES THAT IT ALONE HAS DETERMINED THAT THE PRODUCTS WILL SUITABLY MEET THE REQUIREMENTS OF THEIR INTENDED USE.

Omron further disclaims all warranties and responsibility of any type for claims or expenses based on infringement by the Products or otherwise of any intellectual property right. (c) Buyer Remedy. Omron's sole obligation hereunder shall be, at Omron's election, to (i) replace (in the form originally shipped with Buyer responsible for labor charges for removal or replacement thereof) the non-complying Product, (ii) repair the non-complying Product, or (iii) repay or credit Buyer an amount equal to the purchase price of the non-complying Product; provided that in no event shall Omron be responsible for warranty, repair, indemnity or any other claims or expenses regarding the Products unless Omron's analysis confirms that the Products were properly handled, stored, installed and maintained and not subject to contamination, abuse, misuse or inappropriate modification. Return of any Products by Buyer must be approved in writing by Omron before shipment. Omron Companies shall not be liable for the suitability or unsuitability or the results from the use of Products in combination with any electrical or electronic components, circuits, system assemblies or any other materials or substances or environments. Any advice, recommendations or information given orally or in writing, are not to be construed as an amendment or addition to the above warranty.

See <http://www.omron.com/global/> or contact your Omron representative for published information.

### Limitation on Liability; Etc.

OMRON COMPANIES SHALL NOT BE LIABLE FOR SPECIAL, INDIRECT, INCIDENTAL, OR CONSEQUENTIAL DAMAGES, LOSS OF PROFITS OR PRODUCTION OR COMMERCIAL LOSS IN ANY WAY CONNECTED WITH THE PRODUCTS, WHETHER SUCH CLAIM IS BASED IN CONTRACT, WARRANTY, NEGLIGENCE OR STRICT LIABILITY.

Further, in no event shall liability of Omron Companies exceed the individual price of the Product on which liability is asserted.

### Suitability of Use.

Omron Companies shall not be responsible for conformity with any standards, codes or regulations which apply to the combination of the Product in the Buyer's application or use of the Product. At Buyer's request, Omron will provide applicable third party certification documents identifying ratings and limitations of use which apply to the Product. This information by itself is not sufficient for a complete determination of the suitability of the Product in combination with the end product, machine, system, or other application or use. Buyer shall be solely responsible for determining appropriateness of the particular Product with respect to Buyer's application, product or system. Buyer shall take application responsibility in all cases.

NEVER USE THE PRODUCT FOR AN APPLICATION INVOLVING SERIOUS RISK TO LIFE OR PROPERTY OR IN LARGE QUANTITIES WITHOUT ENSURING THAT THE SYSTEM AS A WHOLE HAS BEEN DESIGNED TO ADDRESS THE RISKS, AND THAT THE OMRON PRODUCT(S) IS PROPERLY RATED AND INSTALLED FOR THE INTENDED USE WITHIN THE OVERALL EQUIPMENT OR SYSTEM.

### Programmable Products.

Omron Companies shall not be responsible for the user's programming of a programmable Product, or any consequence thereof.

### Performance Data.

Data presented in Omron Company websites, catalogs and other materials is provided as a guide for the user in determining suitability and does not constitute a warranty. It may represent the result of Omron's test conditions, and the user must correlate it to actual application requirements. Actual performance is subject to the Omron's Warranty and Limitations of Liability.

### Change in Specifications.

Product specifications and accessories may be changed at any time based on improvements and other reasons. It is our practice to change part numbers when published ratings or features are changed, or when significant construction changes are made. However, some specifications of the Product may be changed without any notice. When in doubt, special part numbers may be assigned to fix or establish key specifications for your application. Please consult with your Omron's representative at any time to confirm actual specifications of purchased Product.

### Errors and Omissions.

Information presented by Omron Companies has been checked and is believed to be accurate; however, no responsibility is assumed for clerical, typographical or proofreading errors or omissions.