

Agilent L4421A 40-Channel Armature Multiplexer

Data Sheet



- LXI compliance includes built-in Ethernet connectivity
- Fully-featured graphical web interface
- 40 2-wire latching armature relays
- Thermocouple reference junction for temperature measurements (requires external DMM)
- Relay counter
- Scan up to 100 ch/s
- 300 V, 1 A switch; 2 A carry current
- Software drivers for most common programming environments

40-channel multiplexer offers high-performance signal switching wherever your application needs it

The Agilent L4421A is a high-performance 40-channel armature multiplexer that is LXI Class C compliant. With its small size and Ethernet connectivity, this switch can be placed wherever your application needs it.

The L4421A is a versatile multiplexer for general purpose scanning or, when using the module in a non-scanning mode, you can close as many channels as you wish. The low thermal offset characteristics and built-in thermocouple reference on the terminal block, make it ideal for temperature measurements when used with an external DMM. The dense, multi-function switching with 100 channel/second scan rates addresses a broad

spectrum of data acquisition, design verification and functional test applications. The Ethernet connection also simplifies distributed data acquisition so that you can collect data from multiple locations.

Four additional fused inputs (channels 41-44) can route up to 1 A of current to an external DMM, allowing for AC and DC current measurements without the need for external shunt resistors.

Using this LXI instrument, you'll get all the benefits of an Ethernet connection, instrument web interface, standard software drivers and more. The LXI standard is supported by multiple vendors, enabling lower cost of test with accelerated test integration and development.



Switch features for flexible and reliable connections

Connect one of many different points to a single point or create your own custom configuration with multiple switch closures. When configured as a multiplexer, the L4421A features "break before make" connections to ensure that no two signals are connected to each other during a scan.

The sequence feature defines switch sequences and controls complex signal routing to ensure the order of switch closures. Assign a sequence, give it a name and then execute it with the custom name you created.

External trigger capabilities make it easy for you to time and synchronize measurements and other events. The external trigger can be used to determine the beginning or end of data to be acquired.

The L4421A also includes a relay counter to monitor and help predict when relays are nearing their end of life.

Easily route signals to an external DMM

The L4421A switches support signals up to 300 V and 1 A so that no external signal conditioning is required. The 34921T features a built-in thermocouple reference that allows for scanning temperature measurements with an external DMM. The analog bus connector can be used to easily route your multiplexed signals to an external DMM.

Hardware handshake with an external DMM is supported through a channel closed trigger output and a channel advance trigger input.

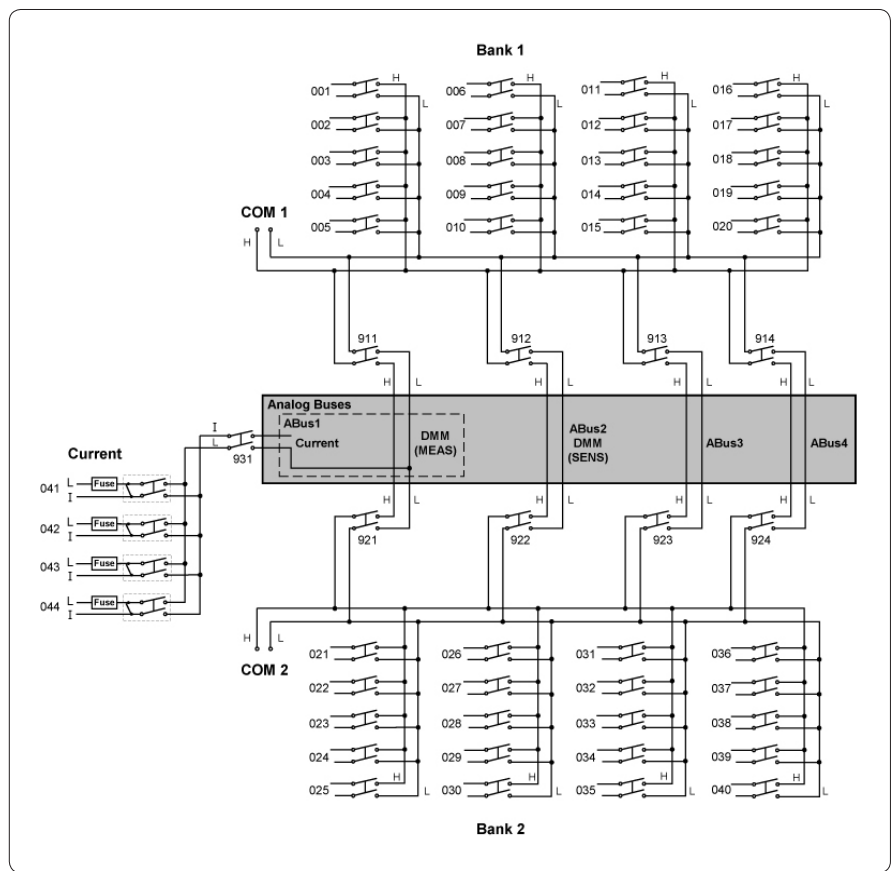

Figure 1. L4421A 40-channel armature multiplexer with low thermal offset (bank 2).

System connections you can trust

The L4421A comes with 2 heavy duty 50-pin Dsub connectors that allow for simple, reliable connections. Each connector uses 30 micro-inches of gold to ensure a repeatable, accurate measurement. Other connection options include:

- Detachable terminal blocks with strain relief
- Low-cost, standard 50-pin Dsub connector kits and cables
- Mass interconnect solutions

Ethernet connectivity enables simple connection to the network and remote access to measurements

The Ethernet interface offers high-speed connections that allow for remote access and control. You can

set up a private network to filter out unwanted LAN traffic and speed up the I/O throughput, or take advantage of the remote capabilities and distribute your tests worldwide. Monitor, troubleshoot, or debug your application remotely. Ethernet communication also can be used with the support of LAN sockets connections.

The optional GPIB interface has many years of proven reliability and can be used for easy integration into existing applications. The L4421A ships with the Agilent E2094N I/O Libraries Suite making it easy for you to configure and integrate instruments into your system — even if your system includes instruments from multiple vendors.

Fully-featured graphical web interface makes it easy to set-up and troubleshoot your tests from anywhere in the world

The built-in web interface provides remote access and control of the instrument via a Java-enabled browser such as Internet Explorer. Using the web interface, you can set up, troubleshoot, and monitor your instrument from remote locations.

- View and modify instrument setup
- Open or close switches
- Send, receive and view SCPI commands
- Define and execute switch sequences
- View error queue
- Get status reports on relay counts, firmware revisions, and more

Additionally, since the web interface is built into the instrument, you can access it from any operating system that supports the web browser without having to install any special software. Password protection and LAN lockout are also provided to limit access for additional security.

Software for most popular programming environments

Full support for standard programming environments ensures compatibility and efficiency. You can use direct I/O with the software you already have, or use standard IVI and LabVIEW software drivers that provide compatibility with the most popular programming environments:

- Agilent T&M Toolkit for Microsoft Visual Studio.NET and Agilent VEE Pro
- National Instruments LabVIEW, LabWindows/CVI, TestStand, and Switch Manager
- Microsoft C/C++ and Visual Basic

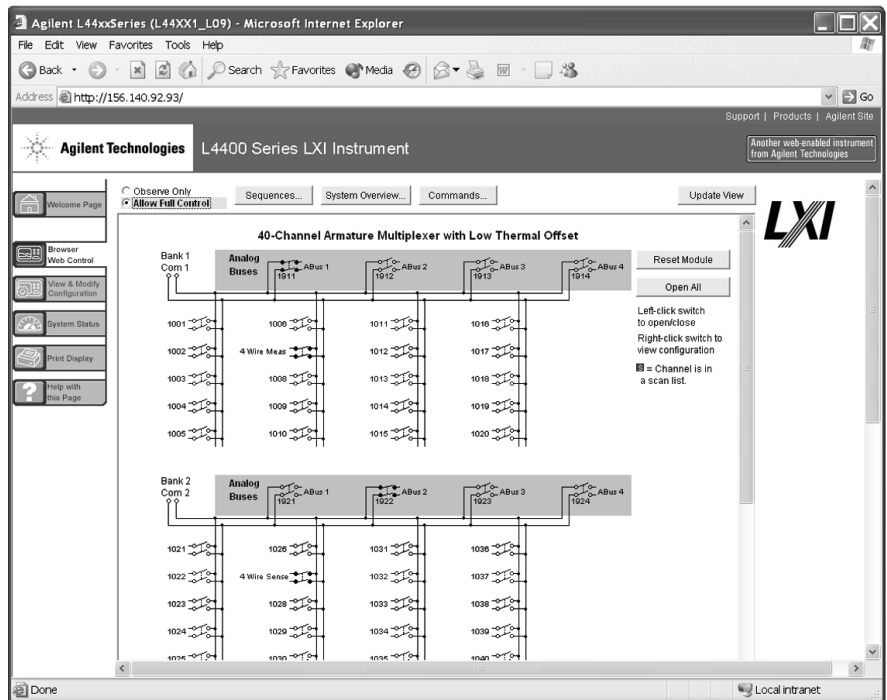
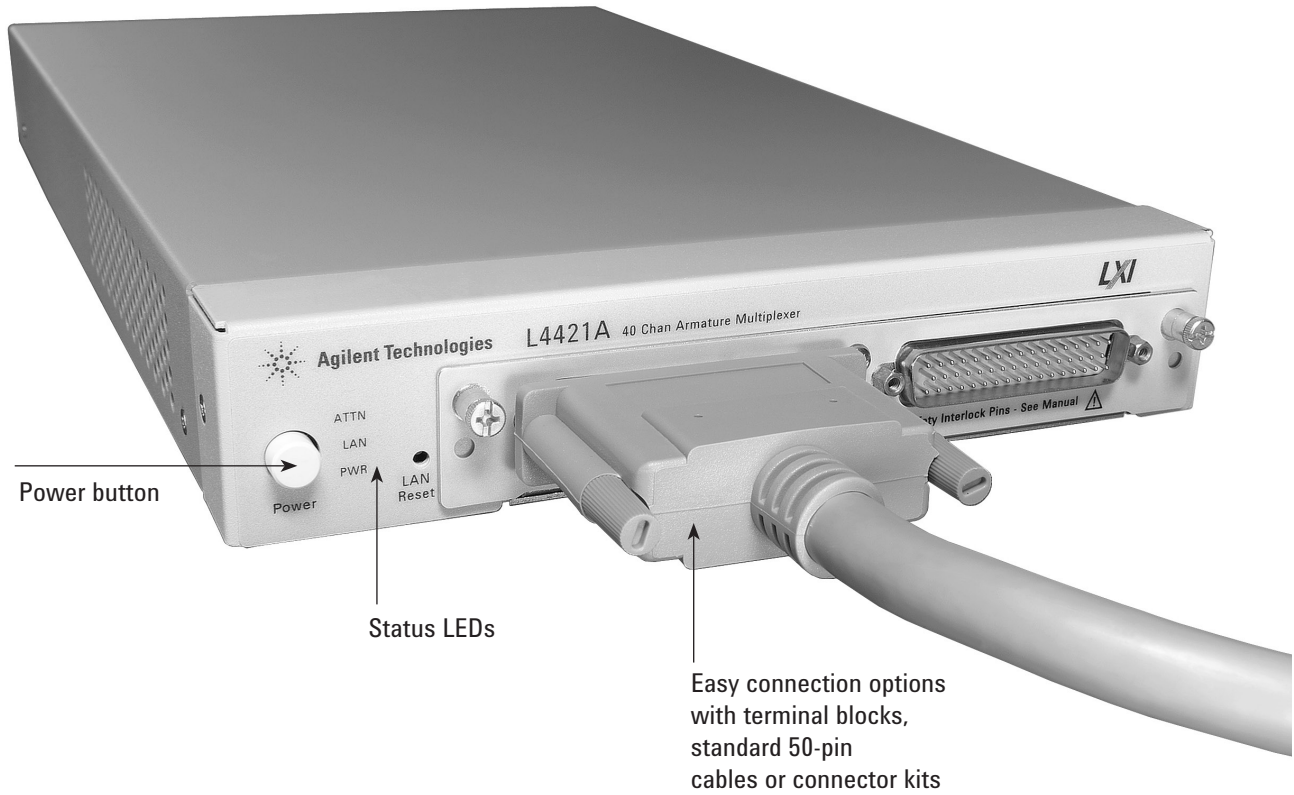

Figure 2. The web interface makes it easy to set up, troubleshoot and maintain your test remotely.

High-performance switching wherever your application needs it



Power button

Status LEDs

Easy connection options with terminal blocks, standard 50-pin cables or connector kits

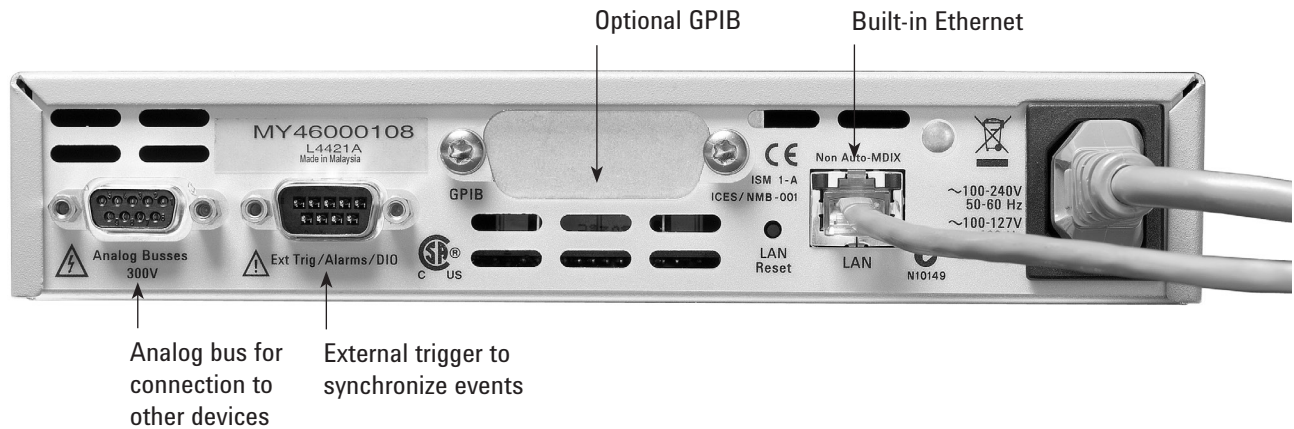

Analog bus for connection to other devices

External trigger to synchronize events

Optional GPIB

Built-in Ethernet

Product Specifications

Specifications and Characteristics		
Channels/configurations		40 2-wire 20 4-wire 4-current (1.5 A fused)
Switch type		Armature Latching
Input characteristics (per channel)		
Max volts (DC, AC RMS) ¹		±300 V
Max current (DC, AC RMS)	Switch current Carry current	1 A 2 A
Power (W, VA) ⁴		60 W
Volt-Hertz limit ⁸		10
Initial closed channel resistance ^{2,7}		< 1.5 Ω
General specifications		
Offset voltage ²		<3 μV
DC Isolation (ch-ch, ch-earth)		>10 GΩ
T/C cold junction accuracy ^{2,6}		< 0.8 °C
AC characteristics		
Bandwidth at terminal block ³		45 MHz
Crosstalk at terminal block (ch-ch) ³	300 kHz 1 MHz 20 MHz 45 MHz	-75 dB -75 dB -50 dB -40 dB
Capacitance at terminal block	HI-LO LO – earth	150 pF 150 pF
General characteristics		
Relay life typical	No load 10 V, 100 mA Rated load =	100 M 10 M 100 k
Scanning speeds ⁵		100 ch/s
Open /close time, typical		4 ms/4 ms
Analog bus connection		Yes

¹ DC or AC RMS voltage, channel-to-channel or channel-to-earth

² At analog bus connector

³ 50 Ohm source, 50 Ohm load, differential measurements verified with 4-port network analyzer (Sdd21)

⁴ Limited to 6 W of channel resistance power loss per module

⁵ Speeds are with an external DMM with 4-½ digits, delay 0, display off, autozero off, and within bank

⁶ Includes 0.5°C error temperature reference sensor and 0.3°C terminal block isothermal gradient error. See User's Guide for information on supported external reference sensors.

⁷ Channel resistance is typically <1.5 Ω but can go as high as 50 Ω if a channel is used in a measurement application with <10 mA load current. Increased relay channel resistance for measurements with load currents below 10 mA can occur on cards that have been out of service or following relay inactivity for periods of greater than 1 week. Switching relays for 2 K cycles prior to use may reduce the variation in channel resistance. Agilent recommends the use of 4-wire Ohms for resistance measurements. For high accuracy voltage measurements, select the DMM input resistance setting of >10 GΩ to minimize the impact of relay contact resistance.

⁸ DC or Peak AC current

Measurement Accuracy For accuracy measurement specification, combine the DMM offset with the switch offset. Bandwidth of the switch may offset the accuracy of the AC measurement.

Product Specifications (continued)

Command Execution Time in msec:		
	GPIB	LAN
Open or Close	4.7	5.3
Init/*WAI	1.9	3
Close/Init/Open	12.4	14
Scanning rates with external DMM (includes switch, DMM measure time and I/O time with Agilent 34401A, 34410A, 34411A)		
	GPIB ch/s	LAN (w/ VXI 11) ch/s
Scanning channels	100	100
Scanning DCV or Ohms	100	100
Scanning ACV	75	75
Scanning temperature	100	100
Scan triggering		
Source	Interval, external, software	
Scan count	1 to 50,000 or continuous	
Scan interval	0 to 99 hours; 1 ms step size	
Channel delay	0 to 60 seconds per channel; 1 ms step size	
External trig delay	< 2ms	
External trig jitter	< 2ms	
Memory		
States	5 instrument states with user label in non-volatile memory	
General system specifications		
Power supply	Universal 100 V to 240 V \pm 10%	
Power line frequency	50 Hz to 60 Hz \pm 10% automatically sensed	
Power consumption	15VA	
Operating environment	Full accuracy for 0°C to 55°C Full accuracy to 80% R.H. at 40 °C Pollution degree 1 of IEC 61010-1	
Storage environment	-40°C to 70°C	
Dimensions (H x W x L)	40.9 x 212.3 x 379.3 mm 1.61 x 8.36 x 14.93 in	
Weight	3.8 kg, 8.4 lbs	
Safety conforms to	CSA, UL/IEC/EN 61010-1	
EMC conforms to	IEC/EN 61326-1, CISPR 11	
Warranty	3 years	

Product Specifications (continued)

Software	
Agilent connectivity	Agilent I/O Libraries Suite 14 or greater (E2094N) software included
Minimum system requirements	
PC hardware	Intel Pentium 100 MHz, 64 Mbyte RAM, 210 Mbyte disk space Display 800x600, 256 colors, CD-ROM drive
Operating system ¹	Windows 98 SE/NT/2000/XP
Computer interfaces	
	Standard LAN 10BaseT/100BaseTx Optional IEEE 488.2 GPIB
Software driver support for programming languages	
Software drivers	IVI-C and IVI-COM for Windows NT/2000/XP LabVIEW
Compatible with programming tools and environments	
Agilent	VEE Pro
National Instruments	TestStand
	Measurement Studio
	LabWindows/CVI
	LabVIEW
	Switch Executive
Microsoft	Visual Studio.NET
	C/C++
	Visual Basic 6

¹ Load I/O Libraries Version M for Windows NT support or version 14.0 for Windows 98 SE support

Ordering information

L4421A 40-chan armature multiplexer

Includes User's guide on CD, power cord, and Quick Start package

Option -GPIB

Adds GPIB interface

Option 0B0

Deletes printed manual set, full documentation included on CD ROM

Option ABA

English printed manual set

Connection Options

Select terminal block for discrete wiring, cables or connector kits. Cables and connector kits require 2 per instrument.

34921T

Terminal block with temp reference for 34921A and L4421A 40-Ch Multiplexer

Y1135A

1.5 m 50-pin Dsub, M/F twisted pair with outer shield cable – 300 V

Y1136A

3 m 50-pin Dsub, M/F twisted pair with outer shield cable – 300 V

Y1139A

Solder cup connector kit with female 50-pin Dsub

Other accessories

Y1160A

Rack mount kit for L4400 series instruments racks 2 instruments side-by-side on sliding tray

Note: When using the L4400 Series Rack Mount Kit, use the Y1139A solder cup connector rather than the 34921T terminal block.

34307A

10-pack of J-type thermocouples

34308A

5-pack of 10 k thermistors

Related literature

Data sheets

5988-6302EN, *Agilent VEE Pro*

5989-1441EN, *Agilent W1140A-TKT T&M Toolkit 2.0 with Test Automation*

5989-1439EN, *Agilent E2094N I/O Libraries Suite 14*



myAgilent

www.agilent.com/find/myagilent

A personalized view into the information most relevant to you.

Agilent Channel Partners

www.agilent.com/find/channelpartners

Get the best of both worlds: Agilent's measurement expertise and product breadth, combined with channel partner convenience.



www.lxistandard.org

LAN eXtensions for Instruments puts the power of Ethernet and the Web inside your test systems. Agilent is a founding member of the LXI consortium.



Three-Year Warranty

www.agilent.com/find/ThreeYearWarranty

Agilent's combination of product reliability and three-year warranty coverage is another way we help you achieve your business goals: increased confidence in uptime, reduced cost of ownership and greater convenience.



Agilent Advantage Services

www.agilent.com/find/AdvantageServices

Accurate measurements throughout the life of your instruments.



www.agilent.com/quality

Agilent Electronic Measurement Group
DEKRA Certified ISO 9001:2008
Quality Management System

www.agilent.com
www.agilent.com/find/L4421A

For more information on Agilent Technologies' products, applications or services, please contact your local Agilent office. The complete list is available at: www.agilent.com/find/contactus

Americas

Canada	(877) 894 4414
Brazil	(11) 4197 3600
Mexico	01800 5064 800
United States	(800) 829 4444

Asia Pacific

Australia	1 800 629 485
China	800 810 0189
Hong Kong	800 938 693
India	1 800 112 929
Japan	0120 (421) 345
Korea	080 769 0800
Malaysia	1 800 888 848
Singapore	1 800 375 8100
Taiwan	0800 047 866
Other AP Countries	(65) 375 8100

Europe & Middle East

Belgium	32 (0) 2 404 93 40
Denmark	45 45 80 12 15
Finland	358 (0) 10 855 2100
France	0825 010 700* *0.125 €/minute
Germany	49 (0) 7031 464 6333
Ireland	1890 924 204
Israel	972-3-9288-504/544
Italy	39 02 92 60 8484
Netherlands	31 (0) 20 547 2111
Spain	34 (91) 631 3300
Sweden	0200-88 22 55
United Kingdom	44 (0) 118 927 6201

For other unlisted countries:

www.agilent.com/find/contactus

(BP-7-22-13)

Product specifications and descriptions in this document subject to change without notice.

© Agilent Technologies, Inc. 2013
Published in USA, September 24, 2013
5989-4825EN



Agilent Technologies