



# AS85049/47 and MS27507 90° Strain Relief Self-Locking or Non-Self-Locking

## CONNECTOR DESIGNATOR:

**F** MIL-DTL-38999 Series I and II

**FOR NEW DESIGN  
USE AS85049/123**

**B**

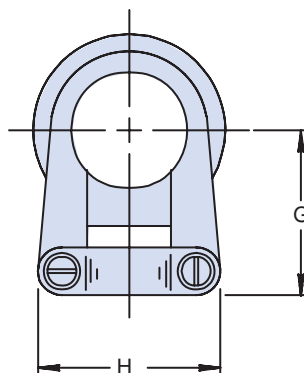
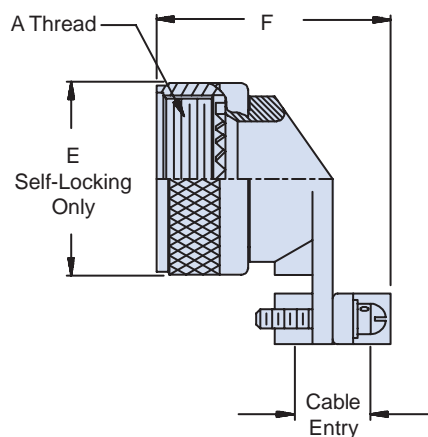
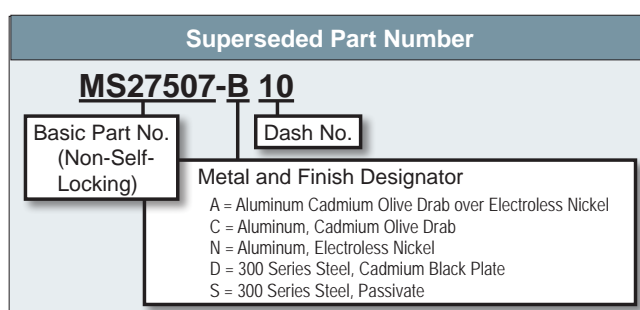
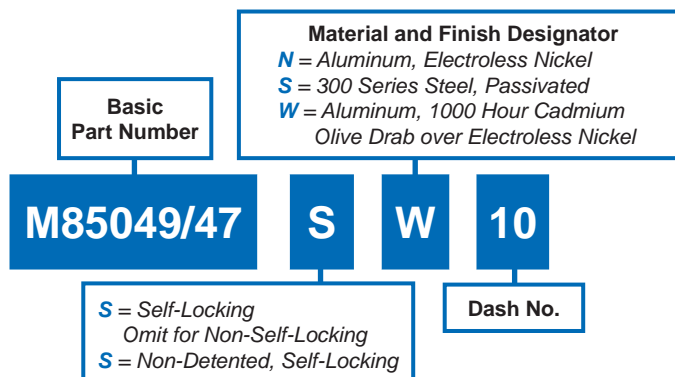

## APPLICATION NOTES

1. Assembly to be identified with manufacturer's name and part number, space permitting.
2. Cable Entry is defined as the accommodation entry for the wire bundle or cable.
3. Dimensions are not intended for inspection criteria.
4. For complete dimensions, see the applicable Military Specification.
5. Metric dimensions (mm) are in parentheses.

**TABLE I: Shell Size, Cable Entry and Backshell Dimensions**

Dash No.	Shell Size Ref.	A Thread Class 2B	Ø E Max		F Max		G Max		H Max		Cable Entry			
											Min	Max		
<b>A</b>	<b>8/9</b>	.438 - 28 UNEF	.86	(21.8)	1.38	(35.1)	1.00	(25.4)	.85	(21.6)	.098	(2.5)	.234	(5.9)
<b>10</b>	<b>10/11</b>	.562 - 24 UNEF	.98	(24.9)	1.38	(35.1)	1.10	(27.9)	.90	(22.9)	.153	(3.9)	.234	(5.9)
<b>12</b>	<b>12/13</b>	.688 - 24 UNEF	1.16	(29.5)	1.46	(37.1)	1.10	(27.9)	1.10	(27.9)	.190	(4.8)	.328	(8.3)
<b>14</b>	<b>14/15</b>	.813 - 20 UNEF	1.28	(32.5)	1.63	(41.4)	1.25	(31.8)	1.15	(29.2)	.260	(6.6)	.457	(11.6)
<b>16</b>	<b>16/17</b>	.938 - 20 UNEF	1.41	(35.8)	1.80	(45.7)	1.30	(33.0)	1.30	(33.0)	.283	(7.2)	.614	(15.6)
<b>18</b>	<b>18/19</b>	1.063 - 18 UNEF	1.52	(38.6)	1.82	(46.2)	1.35	(34.3)	1.50	(38.1)	.325	(8.3)	.634	(16.1)
<b>20</b>	<b>20/21</b>	1.188 - 18 UNEF	1.64	(41.7)	1.90	(48.3)	1.60	(40.6)	1.60	(40.6)	.343	(8.7)	.698	(17.7)
<b>22</b>	<b>22/23</b>	1.313 - 18 UNEF	1.77	(45.0)	2.04	(51.8)	1.75	(44.5)	1.70	(43.2)	.381	(9.7)	.823	(20.9)
<b>24</b>	<b>24/25</b>	1.438 - 18 UNEF	1.89	(48.0)	2.15	(54.6)	1.85	(47.0)	1.80	(45.7)	.418	(10.6)	.853	(21.7)

Dimensions in inches (millimeters) and are subject to change without notice.