

Top View of Assembly

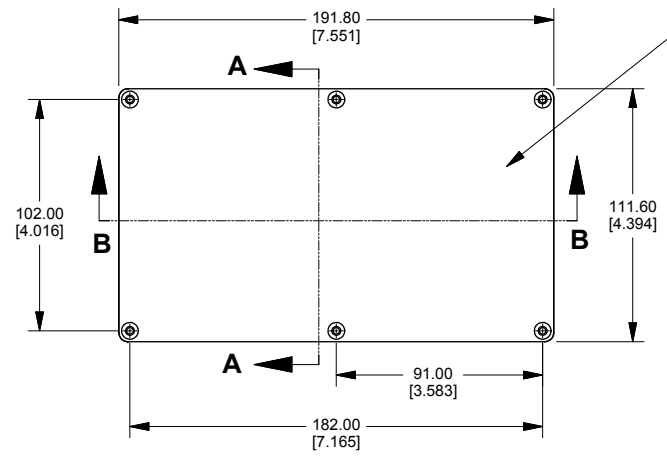

SECTION A-A End View of Assembly

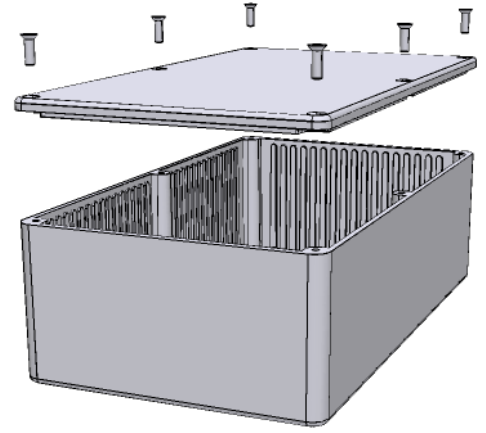
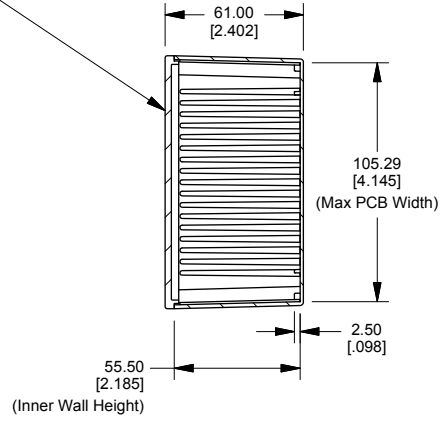

Top View Looking Inside Box

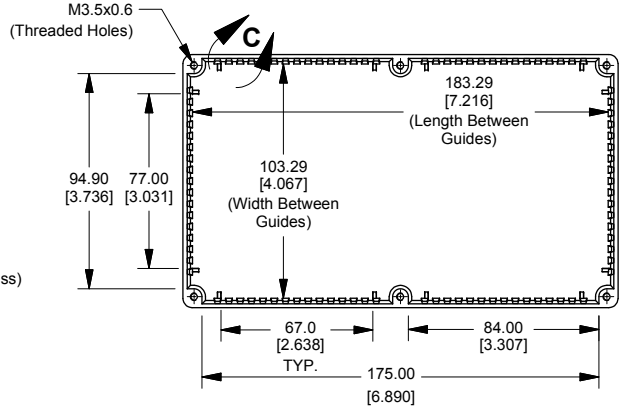

SECTION B-B Side View of Assembly

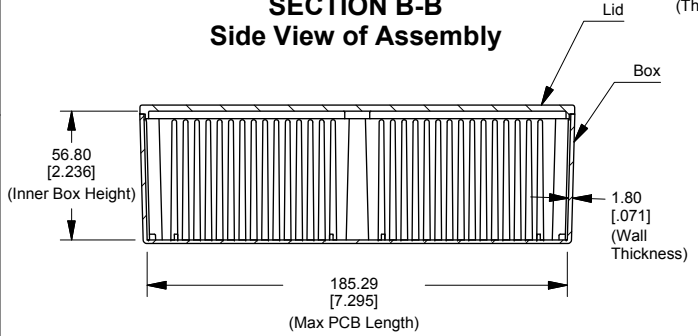

Enclosures can be Factory Modified (Milling, Drilling, Printing etc.)
Contact Factory mjm@hammondmfg.com for quotes
Solid models of this enclosure available in STEP or IGES.

NOTE

Purchased assembly includes box, lid and 6 cover screws.
Box and lid are made from Diecast Aluminum Alloy.

PART NUMBERS

1590R Enclosure	
Natural Finish Enclosure	1590R
Black Textured Enclosure	1590RBK
ACCESSORIES	
Recommended Torque: 75 ozf.in / 55 cN.m	
Plated Cover Screws (Pkg 100) [M3.5 x 12mm]	1550MS100
Black Cover Screws (Pkg 100) [M3.5 x 12mm]	1550MS100BK

Lid

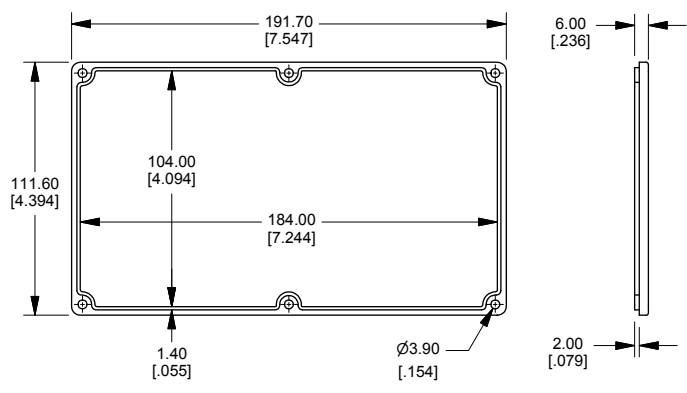

DETAIL C Top View - Interior Features

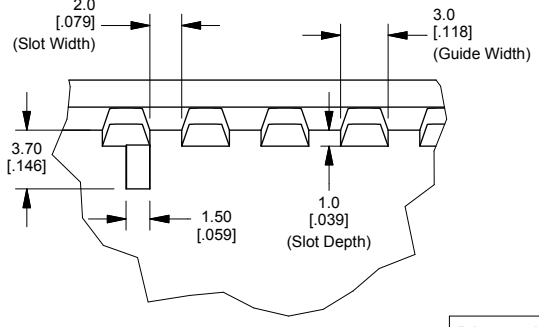

Dimensions:
mm
[inches]

HAMMOND MANUFACTURING™
1590R
www.hammondmfg.com