

HEDS-9200 Series

Linear Optical Incremental Encoder Modules

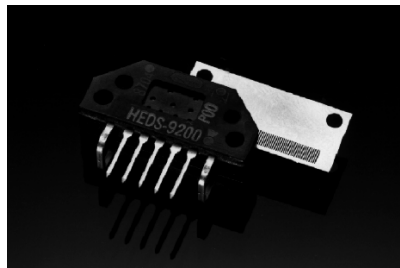

Data Sheet



Note: Codestrip not included with HEDS-9200

Description

The HEDS-9200 series is a high performance, low cost, optical incremental encoder module. When operated in conjunction with a codestrip, this module detects linear position. The module consists of a lensed LED source and a detector IC enclosed in a small C-shaped plastic package. Due to a highly collimated light source and a unique photodetector array, the module is extremely tolerant to mounting misalignment.

The two channel digital outputs and the single 5 V supply input are accessed through four 0.025 inch square pins located on 0.1 inch centers.

Five standard resolutions between 4.72 counts per mm (120 counts per inch) and 7.87 counts per mm (200 counts per inch) are available. Consult local Avago sales representatives for other resolutions ranging from 1.5 to 7.87 counts per mm (40 to 200 counts per inch).

Features

- High performance
- High resolution
- Low cost
- Easy to mount
- No signal adjustment required
- Insensitive to mechanical disturbances
- Small size
- -40° C to 100° C operating temperature
- Two channel quadrature output
- TTL compatible
- Single 5 V supply

Package Dimensions

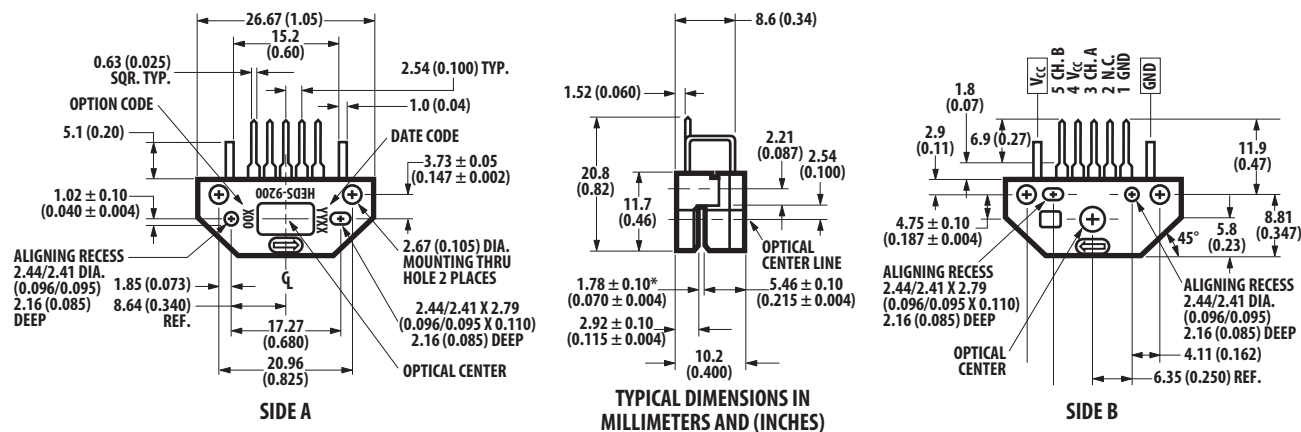

* GAP SPECIFICATION FOR WINDOW OPTION = 1.68 ± 0.10 (0.066 ± 0.004)

ESD WARNING: Normal handling precautions should be taken to avoid static discharge.

Block Diagram

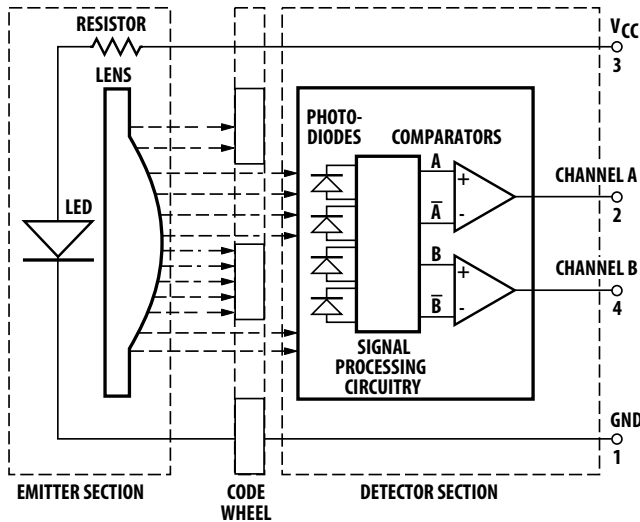

Applications

The HEDS-9200 provides sophisticated motion detection at a low cost, making it ideal for high volume applications. Typical applications include printers, plotters, tape drives, and factory automation equipment.

Note: Avago Technologies encoders are not recommended for use in safety critical applications. Eg. ABS braking systems, power steering, life support systems and critical care medical equipment. Please contact sales representative if more clarification is needed.

Theory of Operation

The HEDS-9200 is a C-shaped emitter/detector module. Coupled with a codestrip it translates linear motion into a two-channel digital output.

As seen in the block diagram, the module contains a single Light Emitting Diode (LED) as its light source. The light is collimated into a parallel beam by means of a single polycarbonate lens located directly over the LED. Opposite the emitter is the integrated detector circuit. This IC consists of multiple sets of photodetectors and the signal processing circuitry necessary to produce the digital waveforms.

The codestrip moves between the emitter and detector, causing the light beam to be interrupted by the pattern of spaces and bars on the codestrip. The photodiodes which detect these interruptions are arranged in a pattern that corresponds to the count density of the codestrip. These detectors are also spaced such that a light period on one pair of detectors corresponds to a dark period on the adjacent pair of detectors. The photodiode outputs are then fed through the signal processing circuitry resulting in A, \bar{A} , B and \bar{B} . Two comparators receive these signals and produce the final outputs for channels A and B. Due to this integrated phasing technique, the digital output of channel A is in quadrature with that of channel B (90 degrees out of phase).

Output Waveforms

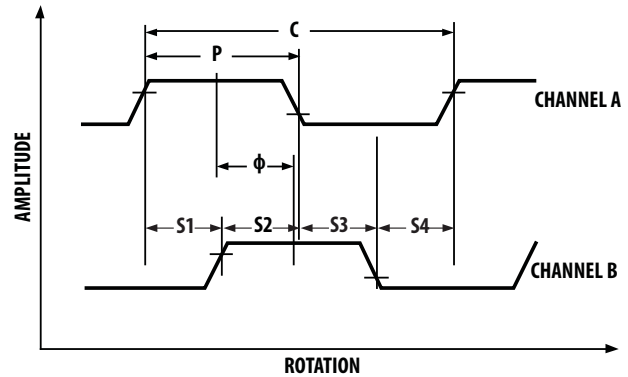

Definitions

Count density (D): The number of bar and window pairs per unit length of the codestrip.

Pitch: $1/D$, The unit length per count.

Electrical degree ($^{\circ}e$): $\text{Pitch}/360$, The dimension of one bar and window pair divided by 360.

1 cycle (C): 360 electrical degrees, 1 bar and window pair.

Pulse Width (P): The number of electrical degrees that an output is high during 1 cycle. This value is nominally $180^{\circ}e$ or $1/2$ cycle.

Pulse Width Error (ΔP): The deviation, in electrical degrees, of the pulse width from its ideal value of $180^{\circ}e$.

State Width (S): The number of electrical degrees between a transition in the output of channel A and the neighboring transition in the output of channel B. There are 4 states per cycle, each nominally $90^{\circ}e$.

State Width Error (ΔS): The deviation, in electrical degrees, of each state width from its ideal value of $90^{\circ}e$.

Phase (ϕ): The number of electrical degrees between the center of the high state of channel A and the center of the high state of channel B. This value is nominally $90^{\circ}e$ for quadrature output.

Phase Error ($\Delta\phi$): The deviation of the phase from its ideal value of $90^{\circ}e$.

Direction of Movement: When the codestrip moves, relative to the module, in the direction of the arrow on top of the module, channel A will lead channel B. If the codestrip moves in the opposite direction, channel B will lead channel A.

Absolute Maximum Ratings

Parameter	Symbol	Min.	Typ.	Max.	Units	Notes
Storage Temperature	T _S	-40		100	°C	
Operating Temperature	T _A	-40		100	°C	
Supply Voltage	V _{CC}	-0.5		7	Volts	
Output Voltage	V _O	-0.6		V _{CC}	Volts	
Output Current per Channel	I _O	-10		5	mA	

Recommended Operating Conditions

Parameter	Symbol	Min.	Typ.	Max.	Units	Notes
Temperature	T	-40		100	°C	
Supply Voltage	V _{CC}	4.5		5.5	Volts	Ripple < 100 mVp-p
Load Capacitance	C _L			100	pF	3.2 KΩ Pull-Up Resistor
Count Frequency	f			100	kHz	Velocity $\left(\frac{\text{inch}}{\text{sec}} \times \frac{\text{Counts}}{\text{inch}} \right)$

Note: The module performance is guaranteed to 100 kHz but can operate at higher frequencies.

Encoding Characteristics

Encoding Characteristics Over Recommended Operating Range and Recommended Mounting Tolerances. These Characteristics Do Not Include Codestrip Defects.

Parameter	Symbol	Min.	Typ.	Max.	Units	Notes
Pulse Width Error	ΔP		7	35	elec. deg.	
Logic State Width Error	ΔS		5	35	elec. deg.	
Phase Error	Δφ		2	13	elec. deg.	

Electrical Characteristics

Electrical Characteristics Over Recommended Operating Range, Typical at 25° C

Parameter	Symbol	Min.	Typ.	Max.	Units	Notes
Supply Current	I _{CC}		17	40	mA	
High Level Output Voltage	V _{OH}	2.4			Volts	I _{OH} = -40 μA Max.
Low Level Output Voltage	V _{OL}			0.4	Volts	I _{OL} = 3.2 mA
Rise Time	t _r		200		ns	C _L = 25 pF
Fall Time	t _f		50		ns	R _L = 11 KΩ Pull-Up

Note:

1. For improved performance in noisy environments or high speed applications, a 3.3 kΩ pull-up resistor is recommended.

Derating Curves over Extended Operating Frequencies (HEDS-9200 Series)

Below are the derating curves for state, duty, phase and V_{OH} over extended operating frequencies of up to 240 kHz (recommended maximum frequency is 100 kHz). The curves were derived using standard TTL load. -40°C operation is not feasible above 160 kHz because V_{OH} will drop below 2.4 V (the minimum TTL for logic state high) beyond that frequency.

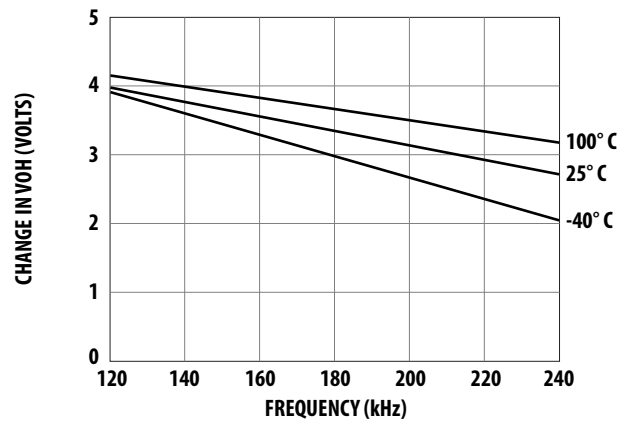
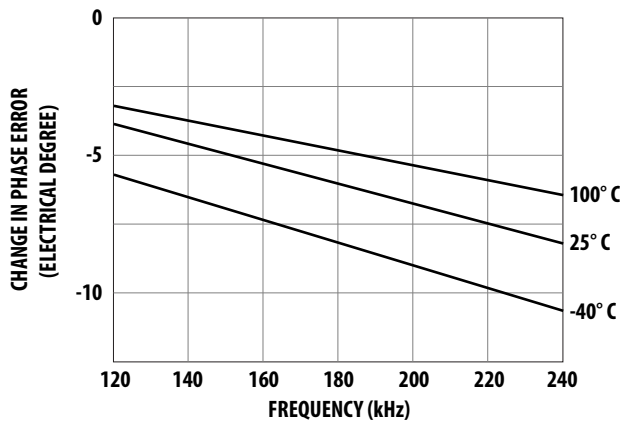
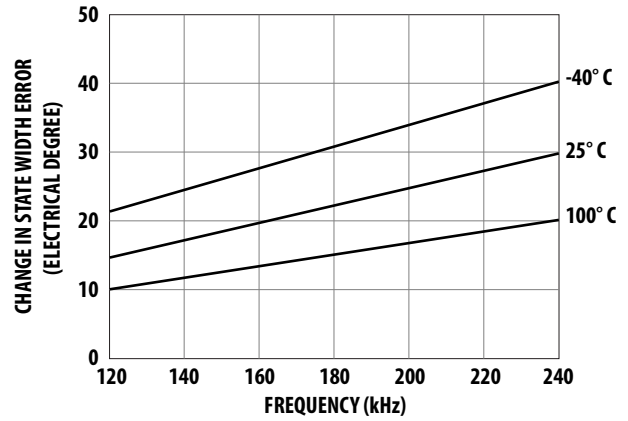
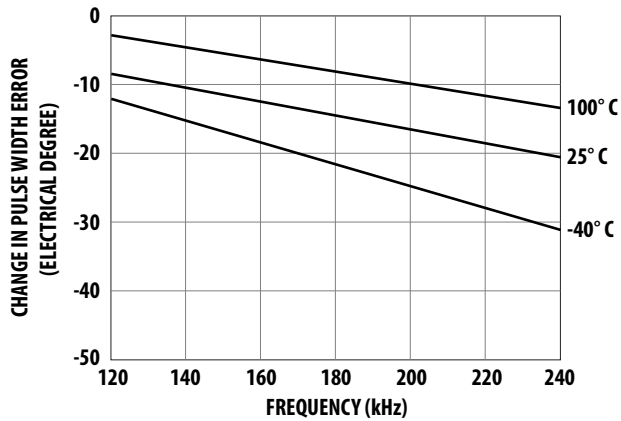

Recommended Codestrip Characteristics

Codestrip design must take into consideration mounting as referenced to either side A or side B (see Figure 4).

Mounting as Referenced to Side A

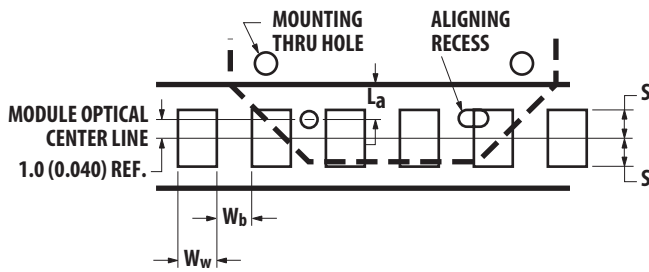

Mounting as Referenced to Side B

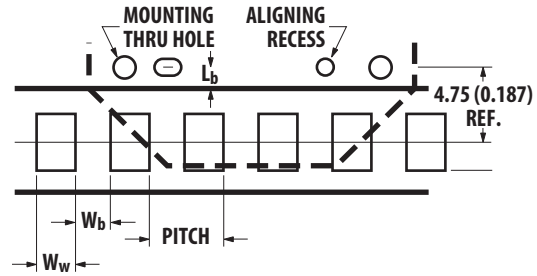

Figure 1. Codestrip Design.

STATIC CHARGE WARNING: Large static charge on codestrip may harm module. Prevent accumulation of charge.

Parameter	Symbol	Mounting Ref. Side A	Mounting Ref. Side B	Units
Window/Bar Ratio	W_w/W_b	0.7 min., 1.4 max.	0.7 min., 1.4 max.	
Mounting Distance	L	$L_a \leq 0.51$ (0.020)	$L_b \geq 3.23$ (0.127)	mm (inch)
Window Edge to Module Opt Center Line	S	0.90 (0.035) min.	0.90 (0.035) min.	mm (inch)
Parallelism Module to Codestrip	α	1.3 max.	1.3 max.	deg.

Note: All parameters and equations must be satisfied over the full length of codestrip travel including maximum codestrip runout.

Mounting Considerations

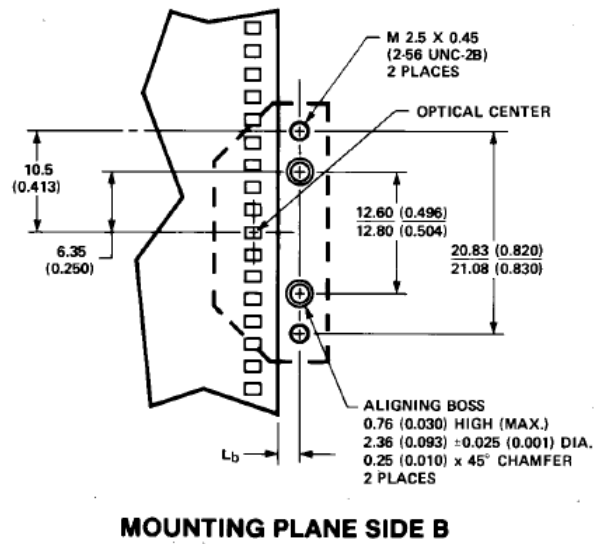
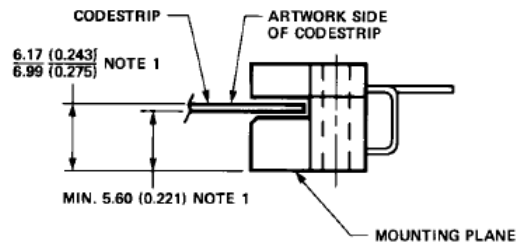
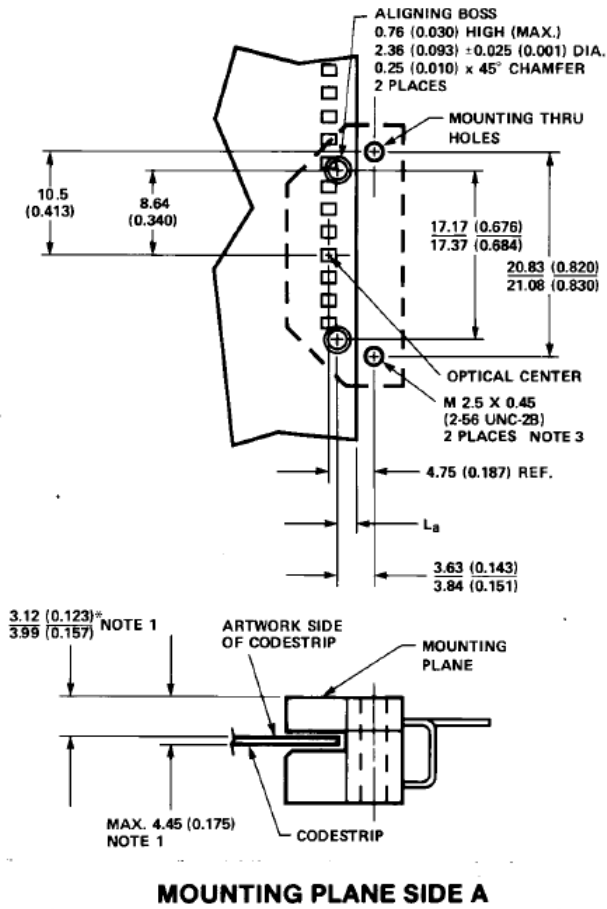

Notes:

1. These dimensions include codestrip warp.
2. Reference definitions of L_a and L_b on page 4.
3. Maximum recommended mounting screw torque is 4 kg-cm (3.5 in-lbs).
4. * For window option measurement = 3.22 (0.127).

Connectors

Manufacturer	Part Number	Mounting Surface
AMP 103686-4	Both 640442-5	Side B
DuPont	65039-032 with 4825X-000 Term.	Both
Avago	HEDS-8902 with 4-wire Leads	Side B
Molex	2695 Series with 2759 Series Term.	Side B

Note: The connectors above do not lock.

Ordering Information

HEDS-9200 Option

Resolution Counts per mm (inch)	Pitch mm (inch) per count
Q00 - 7.09 (180)	10.141 (0.0056)
300 - 11.81 (300)*	0.085 (0.0033)*
360 - 14.17 (360)*	0.071 (0.0028)*

Consult local Avago sales representatives for other resolutions.

* Please refer to separate HEDS-9000/9100/9200 Extended Resolution Series data sheet for detailed information.

For product information and a complete list of distributors, please go to our web site: www.avagotech.com

Avago, Avago Technologies, and the A logo are trademarks of Avago Technologies in the United States and other countries. Data subject to change. Copyright © 2005-2013 Avago Technologies. All rights reserved. Obsoletes 5988-6711EN AV02-3653EN - December 19, 2013

AVAGO
TECHNOLOGIES