

IEC Appliance Inlet C14 with Fuseholder 1- or 2-pole

Medical fuse drawer



V-Lock



Inlet with fuseholder (5x20 mm)

KPF Filter Module  
(not enclosed)



**Description**

- Panel Mount:  
Sandwich/rear-side
- 2 Functions:  
Appliance Inlet Protection class I, Fuseholder for fuse-links 5 x 20 mm  
1- or 2-pole
- For PCB mounting

**Approvals**

- Approval Reference Type: KP01
- VDE Certificate Number: 40029370
- UL File Number: E93617
- CSA File Number: 38456
- CCC File Number: 2013010204594658

**Characteristics**

- Panel mount from rear or "sandwich" between top and bottom/side to side panels  
PCB mount with snap-in or screw-on feet (self tapping screws Ø 3 x 8 mm)
- All single elements are already wired
- Fuse drawer meets requirements of medical standard IEC/EN 60601-1  
The fuse drawer can only be opened with the aid of a tool  
The fuseholder is accessible from the equipment front
- Insulation cover on the rear-side
- Suitable for use in equipment according to IEC/UL 60950

**Other versions on request**

- Solder terminals
- Quick-connect terminals
- For protection class II

**References**

Alternative: version with line filter [KPF](#)

**Weblinks**

[pdf-datasheet](#), [html-datasheet](#), [General Product Information](#), [Approvals](#), [CE declaration of conformity](#), [RoHS](#), [CHINA-RoHS](#), [Mating Connectors](#), [e-Shop](#), [SCHURTER-Stock-Check](#), [Distributor-Stock-Check](#), [CAD-Drawings](#), [Accessories](#), [Detailed request for product](#)

Newly available variants corresponding to V-Lock mating cordset. The connector is equipped with a notch intended for use with the latching cordset. The cord latching system prevents against accidental removal of the cordset.

**Technical Data**

Ratings IEC	10A / 250VAC; 50Hz	Appliance Inlet	C14 acc. to IEC 60320, UL 498, CSA C22.2 no. 42 (for cold conditions) pin-temperature 70 °C, 10A, Protection Class I
Ratings UL/CSA	10A / 125VAC; 60Hz	Fuseholder	1 or 2 pole, Shocksafe category PC2 acc. to IEC 60127-6, for fuse-links 5 x 20mm
Dielectric Strength	> 2.3kVAC between L-N > 2.8kVAC between L/N-PE (1 min/50Hz)	Rated Power Acceptance @ Ta 23 °C	5 x 20: 2W (1 pole)/ 1.6W (2-pole) per pole
Allowable Operation Temp.	-25 °C to 70 °C	Power Acceptance @ Ta > 23 °C	Admissible power acceptance at higher ambient temperature see derating curves
Degree of Protection	from front side IP 40 acc. to IEC 60529		
Protection Class	Suitable for appliances with protection class I acc. to IEC 61140		
Terminal	For PCB mounting Quick connect terminals 4.8 x 0.8 mm Solder terminal on request		
Panel Thickness s	Snap-in: 1.5/2/2.5/3 mm		
Material: Housing	Thermoplastic, black, UL 94V-0		

**Dimensions**

**Screw-on mounting**

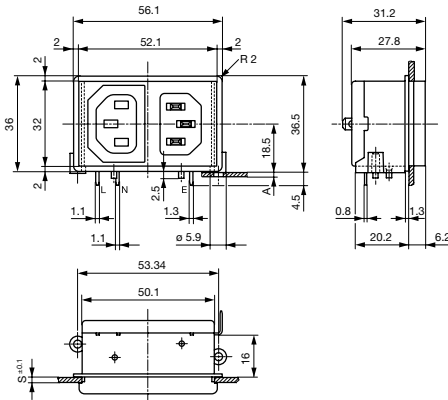

A = for PCB-thickness 1.2/1.6/2.0/2.4 mm  
Additional quick connect terminal 4.8 x 0.8 mm  
For 2-pole inlet/switch, 2-pole inlet fuseholder and inlet/outlet

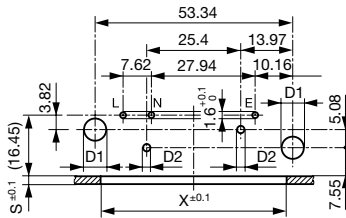

d1 = 6 ± 0.05 für (snap-in)  
d1 = 3.6 (screw-on)  
d2 = 2.1 + 0.1/-0 (screw-on)  
Dimensions without tolerance:  
≤ 15 = ± 0.05; ≥ 15 = ± 0,1

**Snap-in mounting**

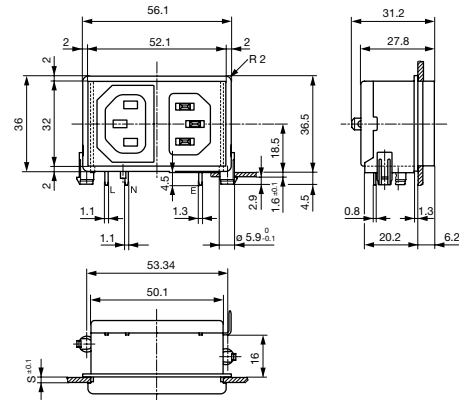

Additional quick connect terminal 4.8 x 0.8 mm  
s = panel thickness  
for combinations:  
inlet/switch 1-pole  
Inlet/ fuseholder 1-pole

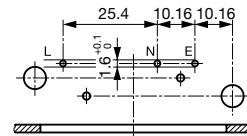

S and X see mounting holes

**Mounting holes for backside mounting**

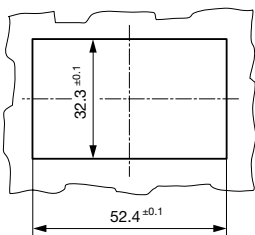

**Sandwich mounting holes**

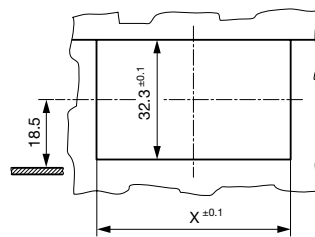

X = 48.4 at S = 1.5 and 2.5  
X = 50.4 at S = 2.0 and 3.0

**Sandwich mounting holes**

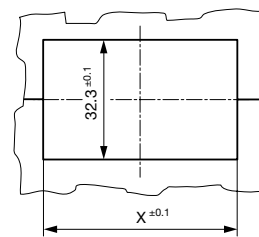

X = 48.4 at S = 1.5 and 2.5  
X = 50.4 at S = 2.0 and 3.0

**Assembly Instructions**

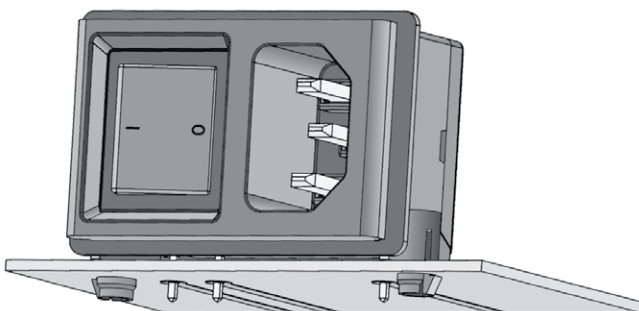

Stable snap feet requires minimal insertion force

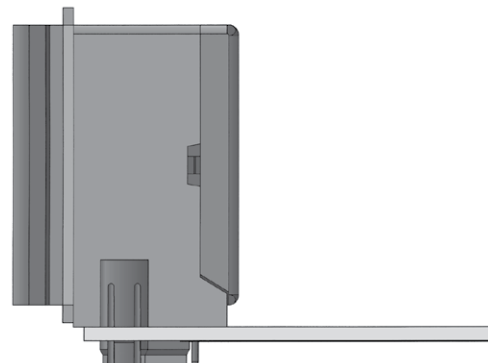

Module must lay flat on the PCB when soldering

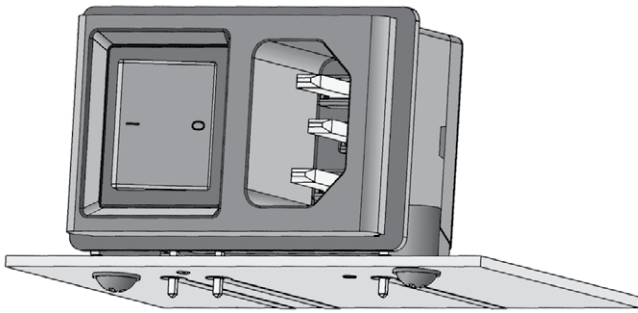

Screw-on mount  
 uses self-tapping screws

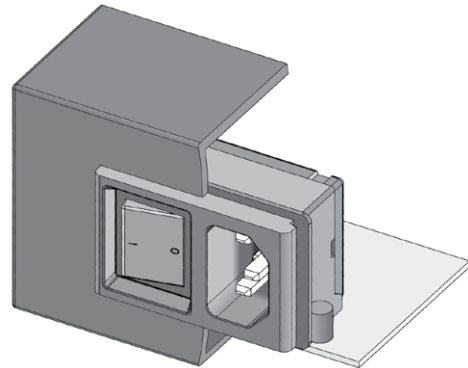

Insertion from behind

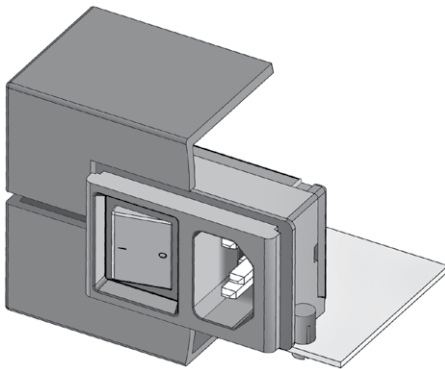

"Sandwich" mounting with split enclosure panels

**Diagrams**

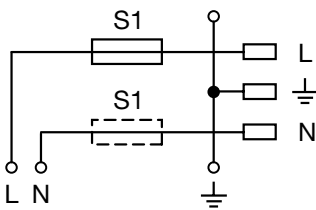

Inlet with fuseholder  
 (5 x 20 mm)

**Derating Curves**

1-pole

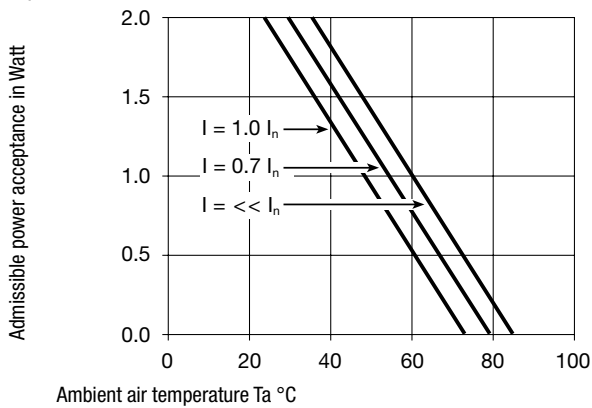

2-pole

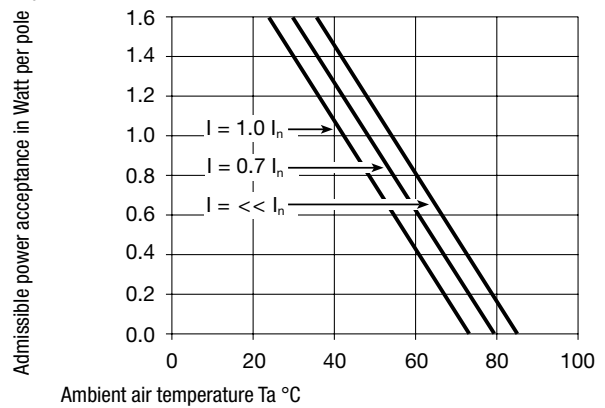

## All Variants

Panel mounting	Panel Thickness [mm]	PCB [mm]	Line Switch	Fuseholder	Connector	Order Number
Screw	2	1.2/1.6/2.0/2.4	-	1-pole	-	KP01.1452.01
Screw	2	1.2/1.6/2.0/2.4	-	2-pole	-	KP01.1352.01
Screw	3	1.2/1.6/2.0/2.4	-	1-pole	-	KP01.1453.01
Screw	3	1.2/1.6/2.0/2.4	-	2-pole	-	KP01.1353.01
Snap-in	2	1.6	-	1-pole	-	KP01.1412.01
Snap-in	2	1.6	-	2-pole	-	KP01.1312.01
Snap-in	3	1.6	-	1-pole	-	KP01.1413.01
Snap-in	3	1.6	-	2-pole	-	KP01.1313.01

Availability for all products can be searched real-time: <http://www.schurter.com/en/Stock-Check/Stock-Check-SCHURTER>

Suffix "21" corresponds to the version with V-Lock mating cordset. The connector is equipped with a notch intended for use with the latching cordset. The cord latching system prevents against accidental removal of the cordset.

Type KP without cover: KP01.XXXX.XX90

Ground Terminal with solder pin: KP01.XXXX.X3XX

**Packaging unit** 50 Pcs

## Mating Outlets/Connectors

### Category / Description



[Appliance Outlet Overview complete](#)

IEC Appliance Outlet F, Screw-on Mounting, Front Side, Solder Terminal	4787
IEC Appliance Outlet F, Snap-in Mounting, Front Side, Solder or Quick-connect Terminal	4788
IEC Appliance Outlet F or H, Screw-on Mounting, Front Side, Solder, PCB or Quick-connect Terminal	5091

[Appliance Outlet further types to KP \(FH\)](#)



[Connector Overview complete](#)

IEC Connector C15A, Rewireable, Straight	0102
IEC Connector C15A, Rewireable, Straight	0102-G
IEC Connector C15A, Rewireable, Angled	0112
IEC Connector C13, Rewireable, Angled	4012
IEC Connector C13, Rewireable, Straight	4022

[Connector further types to KP \(FH\)](#)

## Mating Outlets/Connectors shuttered



[Power Cord Overview complete](#)

Overview Power Supply Cord with IEC Connector C13, V-Lock, straight	VAC13KS
---	---------

[Power Cord further types to KP \(FH\)](#)