

Global Connector Technology Ltd. - USB3145: μ USB Receptacle, Type B, Through Hole, Vertical, With Through Hole Shell Stakes

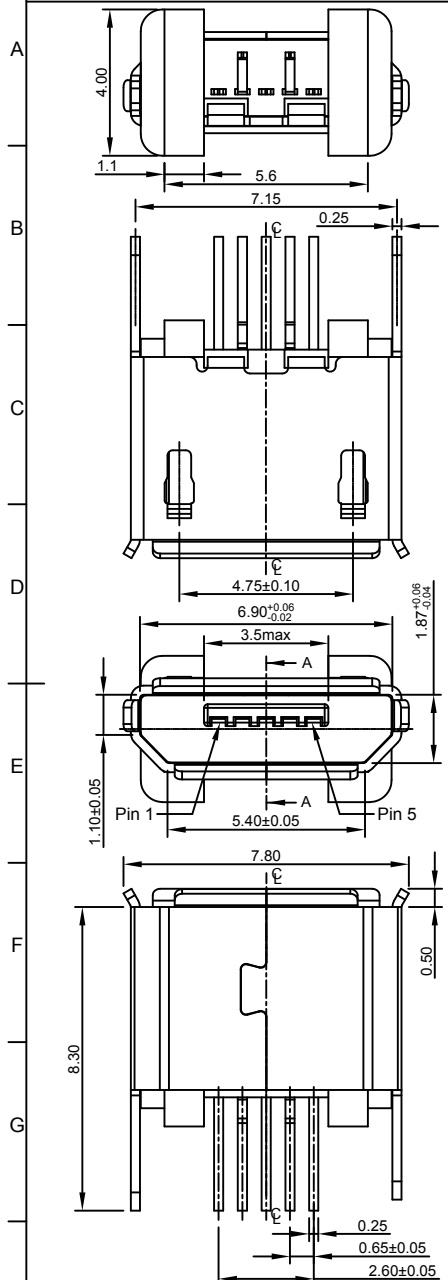

Designed to comply with physical, electrical and environmental requirements of Micro USB Standard (USB2.0)

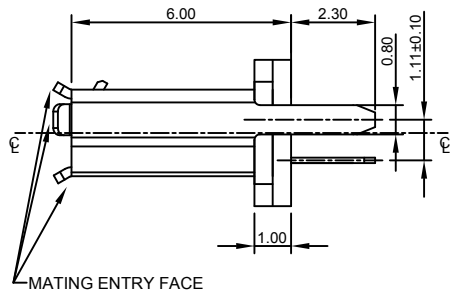
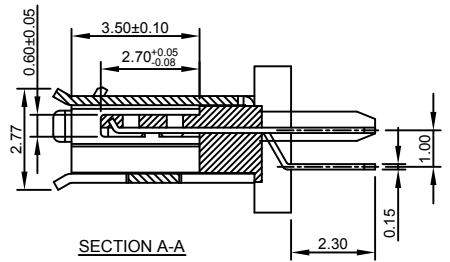

Note: Recommended for 1.6mm PCB thickness, for thinner PCB's choose USB3130 (B) or USB3105 (A/B).

Ordering Grid

USB3145 - 30 - X - A

REQUEST SAMPLES AND QUOTATION

Contact Plating
30 = 30 μ Gold

Packing Options
A = Tape & Reel
(1300 per reel)

Mating Entry Face
1 = With Mating Entry Face (Standard)
0 = Without Mating Entry Face (MOQ = 7800)

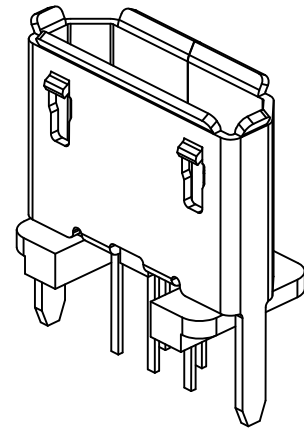

Specifications 规格:

Materials 材料:
Plastic Housing 塑胶外壳: LCP, UL94V-0, Black (黑色)
Contact Terminal 接触端子: Copper Alloy 铜合金.
Metallic Shell 金属外壳: Stainless Steel 不锈钢 T=0.25mm.

Plating电镀:
Underplating 底层电镀: 50 μ Nickel, 50 μ 镍
Finish表面处理: Contact Area 接触面积: 30 μ Gold plating (镀金)
Solder Tails 焊接末端: Gold Flash 镀金
Metallic Shell 金属外壳: Matte Tin 雾锡

Electrical 电气规格:
Voltage Rating 电压额定值: 100 V AC
Current Rating 电流额定值: Signal (Pins 2,3,4)信号: 1.0 A.
Power (Pins 1,5)电源: 1.8A.
Operating Temperature 工作温度: -30°C to +85°C.
Contact Resistance 接触电阻值: 30m Ω Max.
Insulating Resistance 绝缘电阻值: 1000M Ω Min.
Dielectric Withstand Voltage 耐电压: 500V AC/Minute

Mechanical 机械性规格:
Mating Force 插入力: 35N Max.
Unmating Force 拔出力: 8N Min. Δ
Durability 耐久性: 10,000 Cycles 次插拔



| | | | |
|------------------------------|---------------|--|-----------|
| Tolerances (Except as noted) | | Part Number:- | Date:- |
| Dimensions in mm | | USB3145 | 02 APR 13 |
| X.X ± 0.30 | X.X* ± 2° | Description:- | |
| X.XX ± 0.20 | X.XX* ± 1° | μ USB RECEPTACLE, TYPE B, THROUGH HOLE, VERTICAL, WITH THRU HOLE SHELL STAKES | |
| X.XXX ± 0.10 | X.XXX* ± 0.5° | THIS DRAWING IS CONFIDENTIAL AND MUST NOT BE COPIED OR DISCLOSED WITHOUT WRITTEN CONSENT | |
| Third Angle Projection | | Scale | Revision |
| | | NTS | B |
| | | Material | Drawn by |
| | | See Note | ASE |
| | | E & OE | Sheet No. |
| | | | 1/2 |



| | | |
|--------|-----------------|-----------------------|
| By | ASE | ASE |
| DETAIL | DRAWING RELEASE | UNMATING FORCE CHANGE |
| REV | A | B |
| DATE | 02/04/13 | 28/05/13 |

Global Connector Technology Ltd. - USB3145: μ USB Receptacle, Type B, Through Hole, Vertical, With Through Hole Shell Stakes

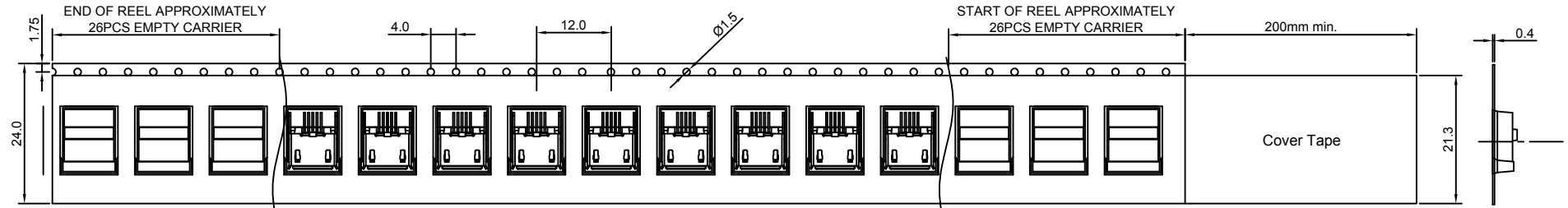

I/O Direction
卷盤繞逆時針方向轉動

Peel off Angle
剝皮角度

| Products P/N | PCS/Reel | Reels/Carton | PCS/Carton |
|--------------|----------|--------------|------------|
| USB3145 | 1300 | 3 | 3900 |

Notes注意:
Peeling off force of top tape: 0.1-1.3N
(Peeling direction as shown)

Materials材料:
Carrier Tape: Polystyrene (PS)
Top Tape: PE
Reel Tape: Polystyrene (PS)

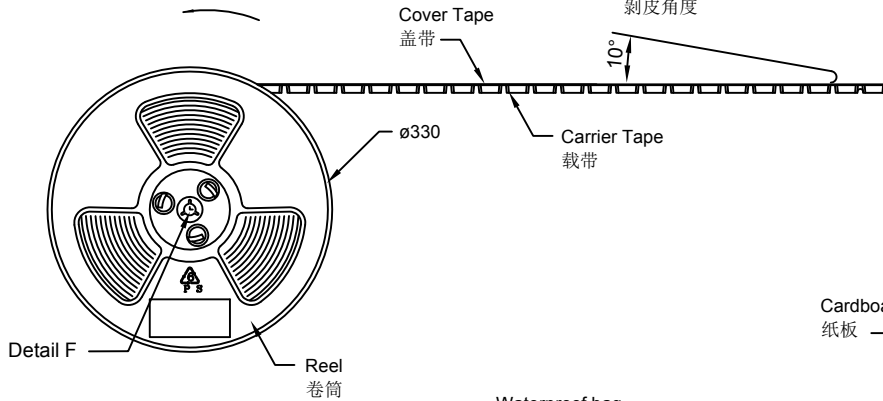

Detail F

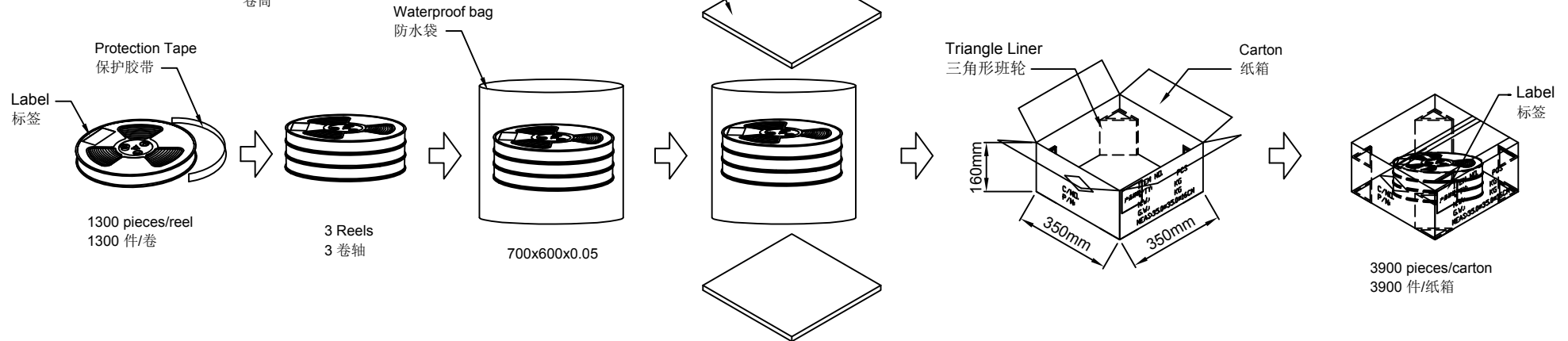

| By | ASE | ASE |
|----------|-----------------|-----------------------|
| DETAIL | DRAWING RELEASE | UNMATING FORCE CHANGE |
| REV DATE | A 02/04/13 | B 28/05/13 |



| Tolerances (Except as noted) | | Part Number:- | Date:- |
|---------------------------------|---------------|--|------------|
| Dimensions in mm | | USB3145 | 02 APR 13 |
| X.X ± 0.50 | X.X° ± 2° | Description:- | |
| X.XX ± 0.30 | X.XX° ± 1° | μ USB RECEPTACLE, TYPE B, THROUGH HOLE, VERTICAL, WITH THRU HOLE SHELL STAKES | |
| X.XXX ± 0.20 | X.XXX° ± 0.5° | © THIS DRAWING IS CONFIDENTIAL AND MUST NOT BE COPIED OR DISCLOSED WITHOUT WRITTEN CONSENT | |
| Third Angle Projection | | Scale NTS | Revision B |

GCT
www.gct.co

| Material See Note | Drawn by ASE | E & OE | Sheet No. 2/2 |
|-------------------|--------------|--------|---------------|
|-------------------|--------------|--------|---------------|