

### Top View of Assembly

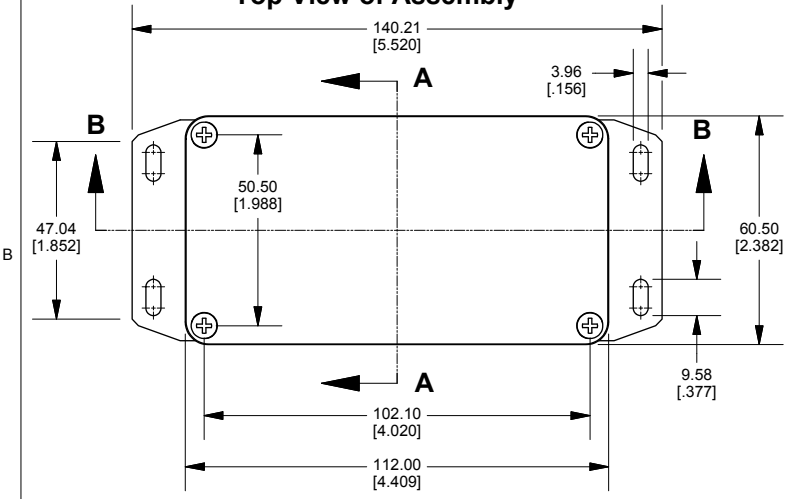

### SECTION A-A End View of Assembly

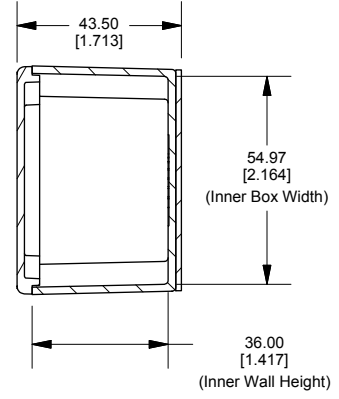

### SECTION B-B Side View of Assembly

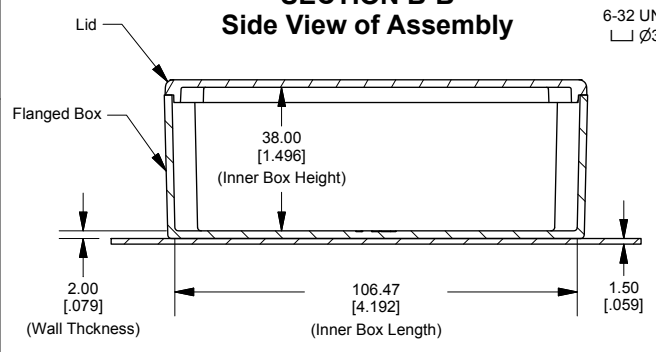

### Top View Looking Inside Box

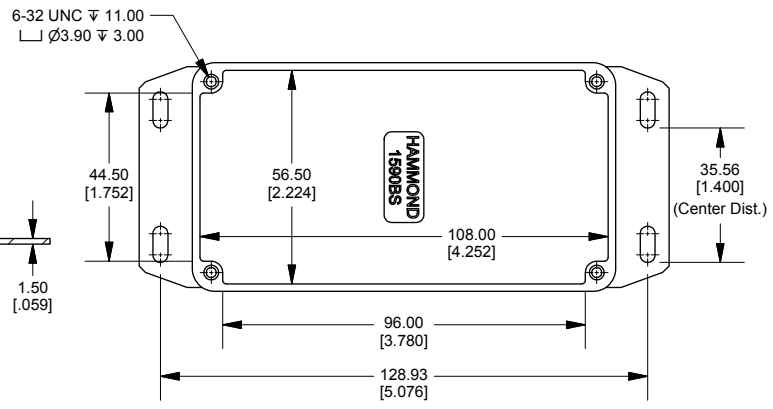

Enclosures can be Factory Modified ( Milling, Drilling, Printing etc.)  
 Contact Factory [mjm@hammondmfg.com](mailto:mjm@hammondmfg.com) for quotes  
 Solid models of this enclosure available in STEP or IGES.

#### NOTE

Purchased assembly includes box, lid and 4 cover screws.  
 Box and lid are made from Diecast Aluminum Alloy.  
 Silicone Gasket supplied with liquid resistant enclosure.  
 Bottom Flange is Welded.

#### PART NUMBERS

1590BSF Enclosure	
Natural Finish Enclosure	1590BSF
Black Textured Enclosure	1590BSFBK
1590BSF Liquid Resistant Enclosure (Silicone Gasket)	
Natural Finish Enclosure	1590WBSF
Black Textured Enclosure	1590WBSFBK

#### ACCESSORIES

Recommended Torque: 75 ozf.in / 55 cN.m	
Liquid Resistant Cover Screws	
Stainless Steel Cover Screws (Pkg 100) [6-32 x 1/2" With O-Ring]	1590WMS100
Black Stainless Steel Cover Screws (Pkg 100) [6-32 x 1/2" With O-Ring]	1590WMS100BK
Standard Cover Screws	
Plated Cover Screws (Pkg 100) [6-32 x 1/2"]	1590MS100
Black Cover Screws (Pkg 100) [6-32 x 1/2"]	1590MS100BK

### Lid

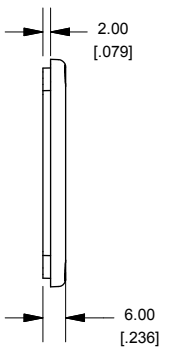
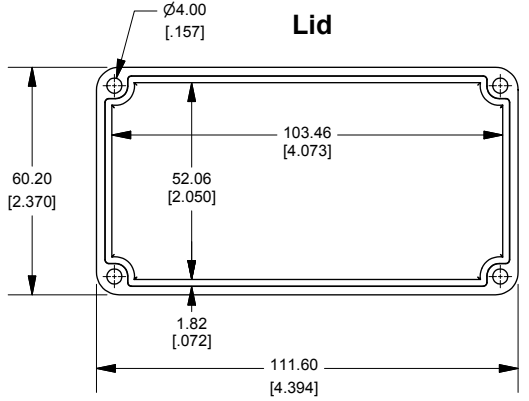

Dimensions:  
mm  
[inches]