

Clarke®



24L OIL FREE AIR COMPRESSOR

MODEL NO: RANGER 6/240

PART NO: 2242010

OPERATION & MAINTENANCE INSTRUCTIONS



LS1013

INTRODUCTION

Thank you for purchasing this CLARKE 24L Oil Free Air Compressor.

Please read this manual fully before use and follow the instructions carefully. In doing so you will ensure the safety of yourself and those around you, and you can look forward to your purchase giving you long and satisfactory service.

GUARANTEE

This product is guaranteed against faulty manufacture for a period of 12 months from the date of purchase. Please keep your receipt which will be required as proof of purchase.

This guarantee is invalid if the product is found to have been abused or tampered with in any way, or not used for the purpose for which it was intended.

Faulty goods should be returned to their place of purchase, no product can be returned to us without prior permission.

This guarantee does not effect your statutory rights.

PARTS AND SERVICING

For Parts & Servicing, please contact your nearest dealer, or CLARKE International, on one of the following numbers.







PARTS & SERVICE TEL: 020 8988 7400
PARTS & SERVICE FAX: 020 8558 3622
or e-mail as follows:
PARTS: Parts@clarkeinternational.com
SERVICE: Service@clarkeinternational.com

SAFETY PRECAUTIONS

Before using your compressor it is in your own interest to read and pay attention to the following safety rules.

1. Compressed air is dangerous. Do not point a jet of air at persons or animals, and do not discharge compressed air against the skin.
2. DO NOT operate your compressor with the guard removed.
3. Repairs must only be carried out by a qualified engineer. If problems occur, contact your Clarke dealer.
4. Before carrying out any maintenance, make sure that the pressure is released from the air reservoir, and that the compressor is disconnected from the electrical supply.
5. DO NOT leave pressure in the receiver overnight, or when transporting.
6. DO NOT adjust, or tamper with the safety valves. The maximum pressure is factory set, and clearly marked on the compressor.
7. DO NOT operate in wet or damp conditions. Keep the compressor dry at all times. Similarly, clean air will allow the compressor to work efficiently. Do not use in dusty or otherwise dirty locations.
8. Some of the metal parts can become quite hot during operation. Do not touch these until the compressor has cooled down.
9. Always set the pressure regulator to the recommended setting for the tool.
10. When spraying flammable materials e.g. cellulose paint, ensure that there is sufficient airflow and keep clear of any source of ignition.
11. Before spraying any material always consult paint manufacturers instructions for safety and usage.
12. Protect yourself. Goggles will protect your eyes from flying particles. Face masks will protect you against paint spray and fumes.
13. Do not apply strain to electrical cables and make sure that air hoses are not kinked or wrapped around the compressor.
14. When disconnecting air hoses or other equipment from your compressor, make sure that the air supply is turned off at the outlet and vent all pressurised air from within the reservoir and other equipment attached to it.
15. Make sure that children and animals are kept well away from the compressor and any equipment attached to it.
16. Make sure that all individuals using the compressor have had the necessary training and have read and fully understand these operating instructions.
17. Make sure that any equipment or tool used in conjunction with your compressor, has a safe working pressure exceeding that of the compressor.
18. Be careful when transporting the compressor to prevent tipping over
19. Permanently installed systems must be installed by a competent engineer.
20. These compressors produce noise levels in excess of 70dB(A). Persons working near the compressor must be supplied with ear protection.

SAFETY SYMBOLS

	<p>Read this instruction booklet carefully before positioning, operating or adjusting the compressor.</p>
	<p>Risk of electric shock. The compressor must be disconnected from the mains supply before removing any covers. Do not use in a damp environment.</p>
	<p>Risk of accidental start-up. The compressor could start automatically in the event of a power cut and subsequent reset. Do not carry the compressor while it is connected to the power source, or when the tank is filled with compressed air.</p>
	<p>This compressor contains surfaces which may reach a high temperature during operation. Never operate with the motor housing removed.</p>
	<p>Wear a safety goggles and ear protectors when using this compressor</p>
 95 dB	<p>This compressor produces a high sound level during operation. Ear protection should be worn.</p>

ELECTRICAL CONNECTIONS



WARNING! Read these electrical safety instructions thoroughly before connecting the product to the mains supply.

Connect the mains lead to a standard, 230 Volt (50Hz) electrical supply through an approved 13 amp BS 1363 plug, or a suitably fused isolator switch.

If the plug has to be changed because it is not suitable for your socket, or because of damage, it must be removed and a replacement fitted, following the wiring instructions shown below. The old plug must be discarded safely, as insertion into a power socket could cause an electrical hazard.



WARNING! The wires in the power cable of this product are coloured in accordance with the following code:

Blue = Neutral Brown = Live Yellow and Green = Earth

If the colours of the wires in the power cable do not agree with the markings on the plug.

- The BLUE wire must be connected to the terminal which is marked N or coloured black.
- The BROWN wire must be connected to the terminal which is marked L or coloured red.
- The YELLOW AND GREEN wire must be connected to the terminal which is marked E or \perp or coloured green.

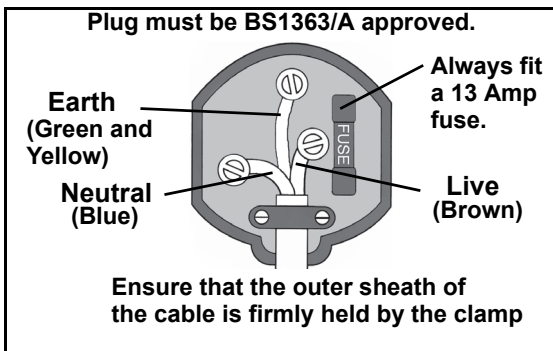

We strongly recommend that this machine is connected to the mains supply through a Residual Current Device (RCD)

If you are not sure, consult a qualified electrician. DO NOT try to do any repairs.

ASSEMBLY

ATTACH THE WHEELS

Use a suitable spanner to attach the wheels to the compressor.

Use the washers and spring washer in the positions shown.

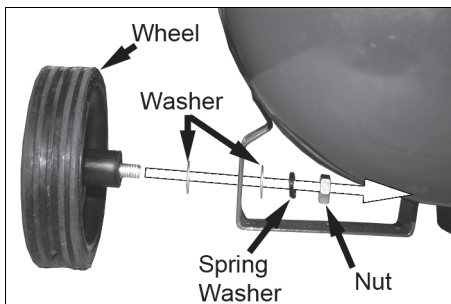

ATTACH THE SUPPORT FOOT

Insert the support foot into the position shown.



FIT THE AIR FILTER

1. If one is fitted, remove the travel plug.
2. Screw the air filter into position.
 - The air filter must be hand tight only.

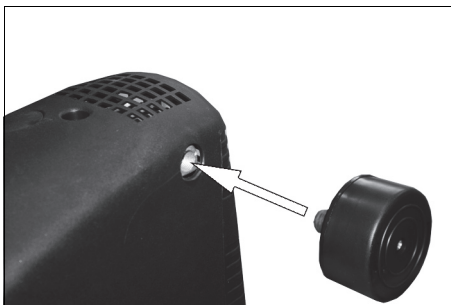

BEFORE USE

Before connecting your compressor to the power supply, check the following:-

- Set the ON/OFF switch to the OFF position (pushed down).
- Make sure that the compressor is on level ground.
- Make sure that the supply voltage matches the voltage shown on the data label.

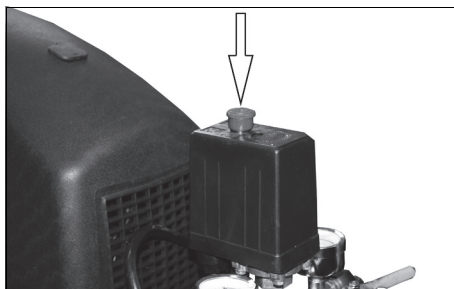

MOVING THE AIR COMPRESSOR



CAUTION: TO PREVENT INJURY, GET ASSISTANCE WHEN LIFTING THIS COMPRESSOR.

-
- Stop the compressor and disconnect it from the power supply before you move it.
 - Always use the handle.
 - To prevent damage, do not lift by (or put strain on) valves or hoses.

OPERATION

If the compressor has not been used for more than 24 hours, open the drain valve (on the bottom of the reservoir) and drain any condensate which has collected. See page 11.

ATTACHING AIR TOOLS



WARNING: BEFORE CONNECTING AIR TOOLS, MAKE SURE THAT YOU READ THE INSTRUCTIONS SUPPLIED WITH THE TOOL, ALSO ENSURE THAT THE TOOL IS SUITABLE FOR USE WITH THE COMPRESSOR AND HOSE SPECIFICATIONS.

1. Attach the air hose to the ¼" BSP outlet valve.
2. Attach the tool to the end of the air hose.

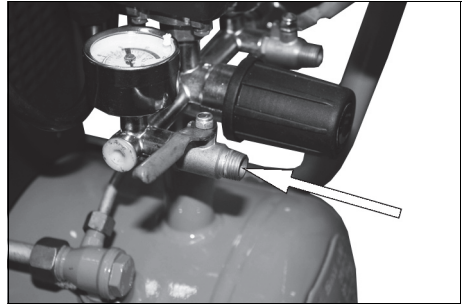

3. Turn the outlet valve handle to the on position.

NOTE: The outlet valve is shown without the air hose fitted for clarity.

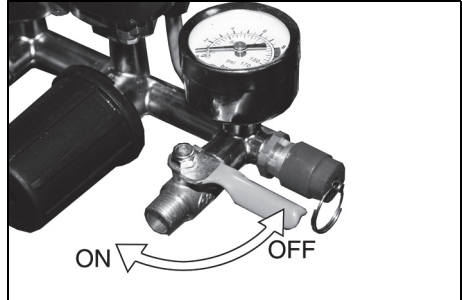

TURNING THE COMPRESSOR ON

1. Plug the compressor into the power supply.
2. Lift the On/Off button.
 - The compressor will operate until the reservoir is fully pressurised. It will then shut down.
 - The compressor will start up again when the pressure in the reservoir decreases.

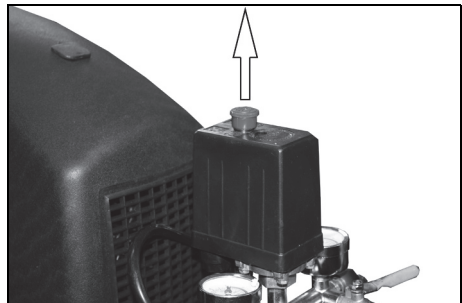

CHECK THE SAFETY VALVE

To make sure that the safety valve works correctly.

1. Pull on the ring attached.
 - Air will be released when you pull on the ring and stop when released.
2. If the valve does not operate in this way, do not use the compressor. The compressor must be repaired by a qualified service agent.

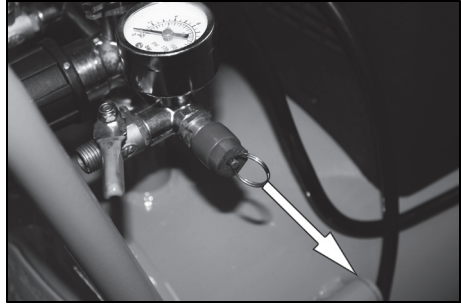

WARNING: DO NOT REMOVE OR TRY TO ADJUST THE SAFETY VALVE.

SET THE OUTPUT PRESSURE

When viewed from the front, the left hand outlet valve is adjustable. The right hand outlet valve will only supply the full reservoir pressure and is not adjustable.

1. Use the pressure regulator to set the output pressure of the left hand outlet valve.
 - Turn clockwise to increase the pressure.
 - Turn counterclockwise to decrease the pressure.

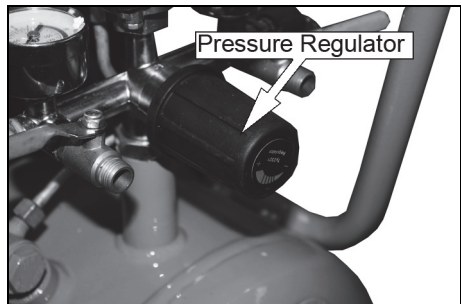

GAUGES

1. The reservoir pressure gauge shows the current pressure in the reservoir.
2. The outlet pressure gauge shows the 'user set' outlet pressure. This can be adjusted as shown above.

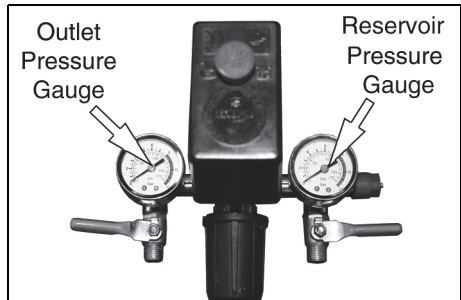

REMOVING TOOLS FROM THE AIR HOSE



WARNING: ALWAYS SET THE PRESSURE REGULATOR TO ZERO BEFORE YOU REMOVE OR REPLACE A TOOL.

1. Push down on the On/Off button to stop the compressor.

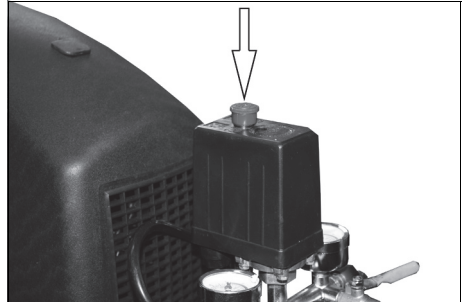

2. Turn the outlet valve handle to the off position.
3. Operate the tool to depressurise the air hose.
4. Disconnect the tool from the hose.

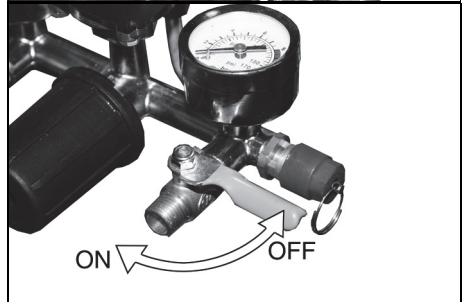

TURNING THE COMPRESSOR OFF

1. Follow steps 1-3 in "Removing Tools From The Air Hose" above.
2. Disconnect the compressor from the power supply.
3. Slowly open one of the outlet valves to depressurise the reservoir.
 - You will hear a hissing sound as the reservoir depressurises.
 - Do not leave the compressor unattended if the reservoir is pressurised.

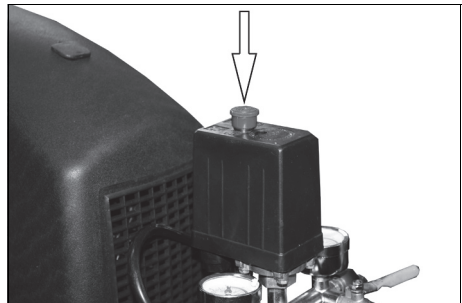

DRAINING THE RESERVOIR



CAUTION: YOU MUST DRAIN THE RESERVOIR AFTER EACH DAYS USE AND BEFORE YOU PUT YOUR COMPRESSOR INTO STORAGE.

1. Turn the compressor off and disconnect from the power supply.
2. Put a container below the drain valve to collect the condensate.
3. Open the drain valve slowly.
 - Condensation will drain from the reservoir.
4. Close the drain valve when the reservoir has fully drained.

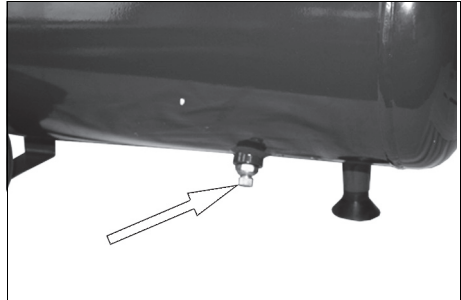

RESET BUTTON

This compressor has a thermal overload device.

If the motor gets too hot, the thermal overload device cuts the power which prevents damage to the motor.

If the thermal overload device operates, let the motor cool down for 5 minutes and push the reset button.

If you start the compressor and the overload cutout operates again, stop the compressor and disconnect from the power supply and have your compressor examined by a qualified service agent.

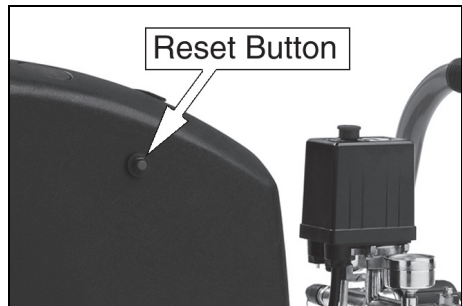

MAINTENANCE

DRAIN THE RESERVOIR (DAILY)

After use, always open the drain valve to make sure that any condensate is drained off.

CLEAN THE AIR FILTER (MONTHLY)

The air filter must be examined monthly, more often in dusty conditions,

1. Remove the filter from the compressor.

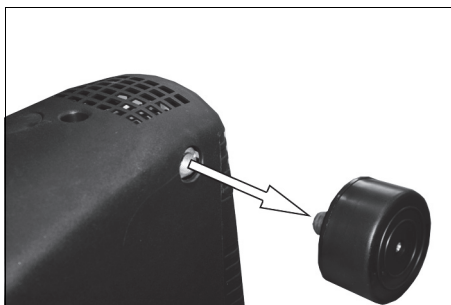

2. Remove the filter cover from the filter.

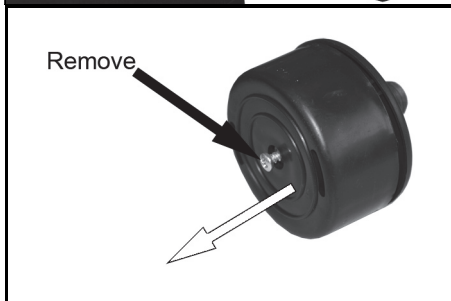

3. Remove the filter from the filter cover.

4. Clean the sponge and the filter cover using a soft brush.

- If necessary, the filter can be carefully cleaned in warm soapy water.
- Rinse and let the filter dry completely before refitting.

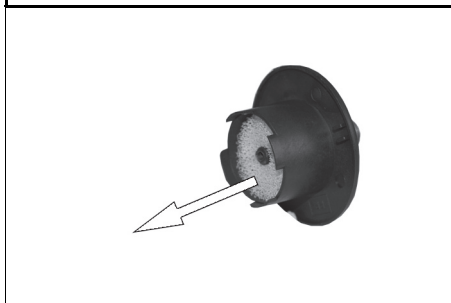

5. Make sure that the filter and filter cover are replaced into position.

- If the filter is damaged, you must replace it.

CHECK THE NON-RETURN VALVE (EVERY 6 MONTHS)

If the reservoir pressure decreases for no apparent reason, it is possible that the non-return valve is leaking. To check,

1. Make sure that the reservoir is not under pressure and the compressor is switched OFF and disconnected from the power supply.
2. Examine the non-return valve, and replace the gasket and valve if necessary.

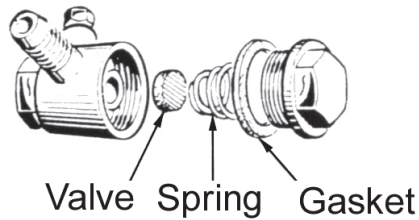
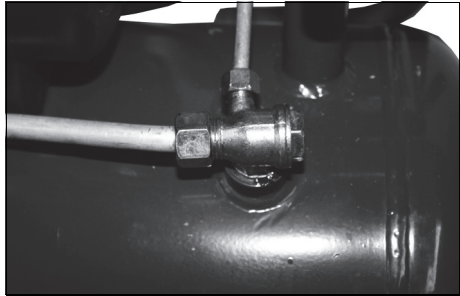

SPECIFICATIONS

Max Pressure	8 Bar
Voltage	230 VAC (50Hz)
Air Displacement	7 CFM
Receiver Capacity	24 L
Fuse Rating	13 A
Dimensions (L x W x H)	545 x 310 x 590 mm
Guaranteed Sound Power Level	95 dB(A)
Weight	23.8 kg

Please note that the details and specifications contained herein, are correct at the time of going to print. We reserve the right to change specifications at any time without prior notice.

TROUBLESHOOTING



CAUTION: DO NOT TRY TO REPAIR OR ADJUST THIS COMPRESSOR IF YOU ARE UNCERTAIN. IF YOU HAVE ANY QUERIES, CONTACT YOUR DEALER.

PROBLEM	PROBABLE CAUSE	REMEDY
The compressor has stopped and does not start.	Bad electrical connections.	<ol style="list-style-type: none"> 1. Check electrical connections. 2. Clean and tighten if necessary.
	Overload cutout switch has tripped.	<ol style="list-style-type: none"> 1. Switch off and wait approx 5 minutes. 2. Press the reset button and switch on again.
	Motor windings burnt out.	<ol style="list-style-type: none"> 1. Contact your Clarke dealer for a replacement motor.
The compressor does not reach the set pressure and overheats easily.	Compressor head gasket blown or valve broken.	<ol style="list-style-type: none"> 1. Return the machine to your nearest service agent.
Compressor does not start.	The reservoir has already fully pressurised.	<ol style="list-style-type: none"> 1. Open drain valve to expel air. Compressor should start again when pressure reduces.
Air leaking from the non-return valve when the compressor is not running.	Faulty non-return valve.	<ol style="list-style-type: none"> 1. Drain receiver completely of air. 2. Remove the valve end plug, 3. Carefully clean the valve seat and the gasket 4. Reassemble.
Air pressure from the regulator will not adjust.	The diaphragm within the regulator body is broken.	<ol style="list-style-type: none"> 1. Replace regulator
The compressor is very noisy and makes a metallic knocking sound.	Compressor damaged and needs overhaul.	<ol style="list-style-type: none"> 1. Return the machine to your nearest service agent.

EXPLODED DIAGRAM

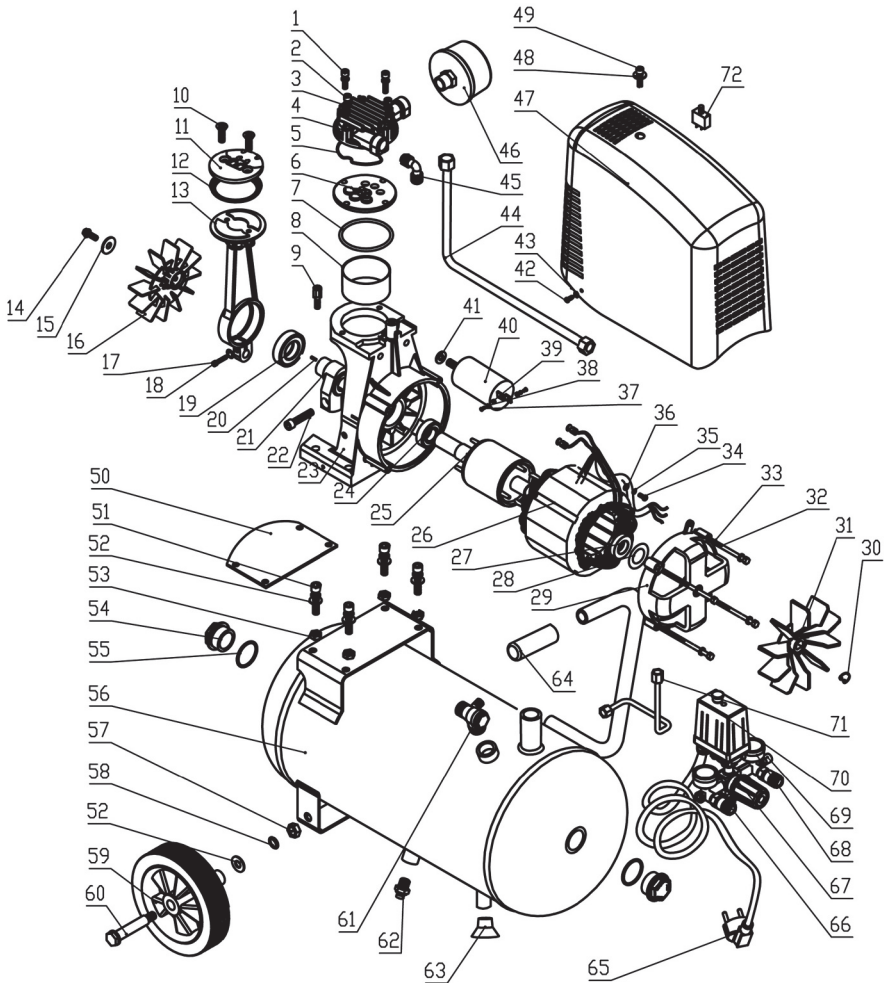

PARTS LIST

NO	DESCRIPTION
1	Bolt M6x25
2	Bolt M6x35
3	Spring Washer
4	Cylinder Head
5	O Ring
6	Valve Plate Subassembly
7	Cylinder Seals
8	Cylinder
9	Connection Stud
10	Screw M5x16
11	Connecting Rod Cover
12	Piston Ring
13	Connecting Rod
14	Bolt M6x16
15	Big Washer 6
16	Fan
17	Bolt M4x20
18	Spring Washer
19	Bearing 6005
20	Pin 4x14
21	Crank
22	Screw M8x35-left
23	Crankcase
24	Bearing 6204-rs
25	Rotor
26	Stator Subassembly
27	Bearing 6202
28	Corrugate Washer 34
29	Motor Bracket
30	Circlip
31	Fan
32	Bolt M5x105
33	Spring Washer
34	Screw M4x10
35	Spring Washer

NO	DESCRIPTION
36	Tooth Washer 4
37	Screw M3x6
38	Spring Washer
39	Nut M3
40	Capacitance
41	Tooth Washer 8
42	Screw St3.9x12
43	Washer 4
44	Discharge Pipe
45	Elbow Connector
46	Air Filter
47	Fan Cover
48	Big Washer 8
49	Screw M7x12
50	Base Board
51	Bolt M8x25
52	Washer 8
53	Flange Nut M8
54	Plug
55	O Ring
56	24l Tank
57	Nut M8
58	Spring Washer 8
59	Wheel 5?
60	Axle
61	Checking Valve
62	Drain Valve 1/4 Inch
63	Absorber
64	Handle Grip
65	Power Cord
66	Quick Coupler
67	Regulate Valve
68	Pressure Gauge
69	Safety Valve
70	Pressure Switch

NO	DESCRIPTION
71	Release Pipe
72	Thermal Protector

DECLARATION OF CONFORMITY



Clarke[®]
INTERNATIONAL

Hemnal Street, Epping, Essex CM16 4LG

DECLARATION OF CONFORMITY

This is an important document and should be retained.

Product Description: Oil free air compressor
Model number(s): Ranger 6/240
Serial / batch Number: N/A
Date of Issue: 16/10/2013
(Noise Conformity)
Notified Body: TÜV SÜD Industrie Service GmbH
Westendstraße 199
80686 MÜNCHEN
Germany
Technical Documentation Holder: A.R. Pond
Clarke International
2a Shrubland Road
London E10 7RB
UK
Conformity Assessment Procedure: to 2000/14/EC Annex VI
Manufacturer: Clarke International
Noise Related Value: 1.5 kW
Measured Sound Power Level: 93 dB
Guaranteed Sound Power Level: 95 dB

DECLARATION OF CONFORMITY



Clarke[®]
INTERNATIONAL

Hernnall Street, Epping, Essex CM16 4LG

DECLARATION OF CONFORMITY

This is an important document and should be retained.

We hereby declare that this product(s) complies with the following directive(s):

- 2004/108/EC *Electromagnetic Compatibility Directive.*
- 2006/42/EC *Machinery Directive.*
- 2011/65/EU *Restriction of Hazardous substances.*
- 2009/105/EC *Simple Pressure Vessel Directive.*
- 2000/14/EC *Noise Emissions Directive, (amended by 2005/88/EC).*

The following standards have been applied to the product(s):

- EN 61000-3-2:2006, EN 55014-2:1997 +A1:2001 +A2:2008, EN 1012-1:1996, EN 61000-3-3:2008,
- EN 60204-1:2006/A1:2009.

The technical documentation required to demonstrate that the product(s) meet(s) the requirement(s) of the aforementioned directive(s) has been compiled and is available for inspection by the relevant enforcement authorities.

The CE mark was first applied in: 2010

Signed:



J.A. Clarke
Director

POPULAR ACCESSORIES

Your local Clarke stockists can supply a wide choice of accessories to help you make the very best of your air compressor. These include:

KIT1000

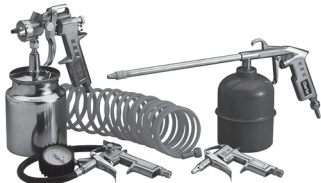

5 Piece Air Accessory Kit – KIT100

Kit comprises:

- Paint spray gun • Recoil hose • Paraffin gun
- Tyre inflator with gauge • Blow gun • All connections 1/4" BSP
- Weight 2kg



CAT116
3/8" Air Drill



CAT118
Sabre Saw

CAT121
Dual
Action
Sander



CAT108
1/2" Square
Drive
Reversible
Ratchet



CAT109
3/8" Square
Drive
Reversible
Ratchet



CAT115
1/2" Reversible
Ratchet



CAT110
1/2" Square
Drive
Impact
Wrench



CAT117
1/2" Impact
Wrench



CAT111
Orbital
Sander



CAT113
3" CUT-OFF TOOL

A comprehensive choice of Clarke spraying equipment is available for your air compressors, including:



PRO12

This professional spraygun is available with a choice of nozzle sizes to suit air compressors from 1.5HP – 3HP.



TG2

Touch up gun ideal for precision paint spraying and touch up work. This syphon fed, external mix spraygun is popular with professionals.

Air hose is available in a range of lengths. Amongst the most popular are:



BLACK RUBBER AIR HOSE

Complete with connections, this hose is available in lengths from 10m to 50m



RECOIL HOSE

Ideal for DIY and professional use, this recoil hose is available in a range of lengths

A SELECTION FROM THE VAST RANGE OF

Clarke®

QUALITY PRODUCTS

AIR COMPRESSORS

From DIY to industrial, Plus air tools, spray guns and accessories.

GENERATORS

Prime duty or emergency standby for business, home and leisure.

POWER WASHERS

Hot and cold, electric and engine driven - we have what you need

WELDERS

Mig, Arc, Tig and Spot. From DIY to auto/industrial.

METALWORKING

Drills, grinders and saws for DIY and professional use.

WOODWORKING

Saws, sanders, lathes, mortisers and dust extraction.

HYDRAULICS

Cranes, body repair kits, transmission jacks for all types of workshop use.

WATER PUMPS

Submersible, electric and engine driven for DIY, agriculture and industry.

POWER TOOLS

Angle grinders, cordless drill sets, saws and sanders.

STARTERS/CHARGERS

All sizes for car and commercial use.



PARTS & SERVICE: 020 8988 7400
E-mail: Parts@clarkeinternational.com or Service@clarkeinternational.com
SALES: UK 01992 565333 or Export 00 44 (0)1992 565335

Clarke® INTERNATIONAL Hemnall Street, Epping, Essex CM16 4LG
www.clarkeinternational.com