

注) NOTES

- 材質 MATERIAL  
ハウジング : ガラス入りPPS、茶色、UL94V-0  
HOUSING:G.F.PPS,BROWN,UL94V-0  
ターミナル : 銅合金 (t=0.2)  
TERMINAL:COPPER ALLOY
- メッキ仕様 PLATING  
接点部 : 金メッキ 0.25 MICROMETER MIN.  
CONTACT AREA:GOLD 0.25 MICROMETER MIN.  
半田付け部 : 錫メッキ 1.0 MICROMETER MIN.  
SOLDER TAIL AREA: TIN 1.0 MICROMETER MIN.  
下地メッキ : ニッケルメッキ 1.5 MICROMETER MIN.  
UNDER-PLATING:NICKEL 1.5 MICROMETER MIN.
- テールのバラツキ寸法 TAILS COPLANARITY  
テール平坦度は 0.1MAX. とする。  
TAILS COPLANARITY TO BE 0.1MAX.
- 本製品は 53551-\*\*\*7 の鉛フリー品である。  
THIS PRODUCT IS LEAD FREE OF 53551-\*\*\*7.

8 mm	52760-***70
14 mm	52837-***70
基板間寸法 STACKING HEIGHT	嵌合相手 TO BE MATED WITH

無し NO	47.42	51.32	46.32	43.815	53936-1476	53551-1478	53551-1479	53551-1477	140
	41.07	44.97	39.97	37.465	---	---	53551-1279	53551-1277	120
	34.72	38.62	33.62	31.115	---	---	53551-1079	53551-1077	100
有り YES	28.37	32.27	27.27	24.765	---	---	53551-0879	53551-0877	80
	25.2	29.1	24.1	21.59	---	53551-0778	53551-0779	53551-0777	70
	22.02	25.92	20.92	18.415	---	53551-0678	53551-0679	53551-0677	60
ハウジングロック H'S'G LOCK	D	C	B	A	トレー梱包 TRAY PACKAGING	エンボス梱包 EMBOSSED PACKAGING	スティック梱包 STICK PACKAGING	製品番号 MATERIAL NO.	極数 CKT. NO.
									MODEL NO. 53551-***77

REVISED EC NO: J2009-0433 DRWN: MAKURAA 2008/11/26 CHKD: T. HARUYAMA 2008/11/26 APPR: NUKITA 2009/01/08	GENERAL TOLERANCES (UNLESS SPECIFIED)		DIMENSION STYLE MM ONLY		SCALE ---	DESIGN UNITS METRIC	THIRD ANGLE PROJECTION	
	10 UNDER	±0.2	DRAWN BY H. SHIMABUKUR	DATE '04/3/22	TITLE 0.635 B/B S/T PLUG HSG ASSY -LEAD FREE-			
	10 OVER 30 UNDER	±0.25	CHECKED BY K. TOJO	DATE '04/3/22	MOLEX INCORPORATED			
	30 OVER	±0.3	APPROVED BY M. SASAO	DATE '04/3/22	DOCUMENT NO. SD-53551-003			
ANGULAR ±3 °		DRAFT WHERE APPLICABLE MUST REMAIN WITHIN DIMENSIONS		MATERIAL NO. SEE TABLE		SHEET NO. 1 OF 1		
THIS DRAWING CONTAINS INFORMATION THAT IS PROPRIETARY TO MOLEX INCORPORATED AND SHOULD NOT BE USED WITHOUT WRITTEN PERMISSION								

注)  
NOTES

- 製品番号 53551-\*\*\*77の詳細寸法については、SD-53551-003を参照ください。  
IN THE PACKAGE, PART NO. 53551-\*\*\*77 DETAILED DIMENSIONS, SEE SD-53551-003
- 梱包数量 : 840 個/リール  
NUMBER OF CONNECTORS : 840 PCS/REEL
- リードテープ長さ  
LEAD TAPE LENGTH

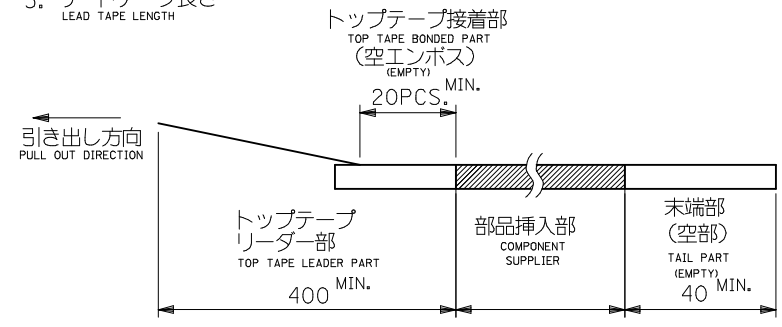
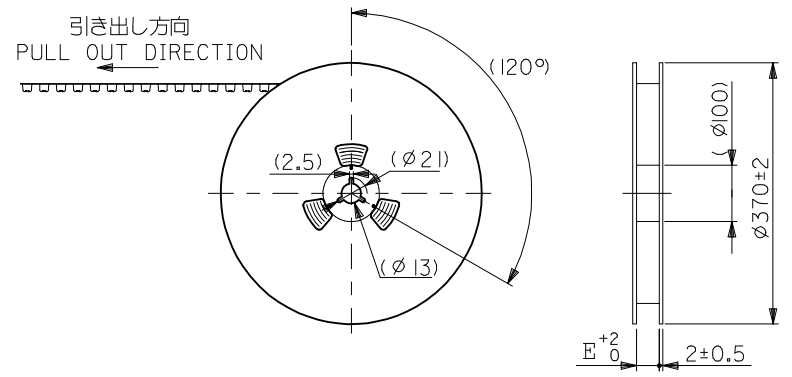

- トップテープの剥離強度 : (剥離方向は下図参照)  
PEELING OFF FORCE OF TOP TAPE (PEELING DIRECTION AS SHOWN IN FOLLOWING FIG.)  
0. 1~1.3N {10~130gf}

尚、本規格値は、出荷時に適用。  
THIS REQUIREMENT SHOULD BE APPLIED AT SHIPMENT  
(但し、輸送時に剥離が発生しない事。)  
(PEEL OFF SHOULD NOT BE ALLOWED, DURING TRANSPORTATION)

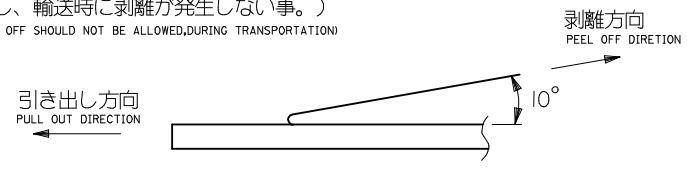

- 材料  
MATERIAL  
キャリアテープ : ポリプロピレン (PP)  
CARRIER TAPE : POLYPROPYLENE (PP)  
トップテープ : PET, PE, PEF  
TOP TAPE : PET, PE, PEF  
リール : 紙  
REEL : CARD BOARD

- 本製品は 53551-\*\*\*8 の鉛フリー品である。  
THIS PRODUCT IS LEAD FREE OF 53551-\*\*\*8

REVISED EC NO: J2009-0433 DRWN: NAKAMURA 2008/11/26 CHKD: T. HARIYAMA 2008/11/26 APPR: NUKITA 2009/01/08	GENERAL TOLERANCES (UNLESS SPECIFIED)		DIMENSION STYLE MM ONLY	SCALE ---	DESIGN UNITS METRIC	53551-***78	MODEL NO.
	10 UNDER	± ---	DRAWN BY S. SHIMABUKUR	DATE '04/3/23	TITILE 53551-***77 TAPING PACKAGE -LEAD FREE-		
	10 OVER 30 UNDER	± ---	CHECKED BY K. TOJO	DATE	MOLEX INCORPORATED		
	30 OVER	± ---	APPROVED BY M. SASAO	DATE	DOCUMENT NO. SD-53551-005	SHEET NO. 1 OF 3	
	ANGULAR ± --- °	MATERIAL NO. SEE TABLE		THIS DRAWING CONTAINS INFORMATION THAT IS PROPRIETARY TO MOLEX INCORPORATED AND SHOULD NOT BE USED WITHOUT WRITTEN PERMISSION			
	DRAFT WHERE APPLICABLE MUST REMAIN WITHIN DIMENSIONS						

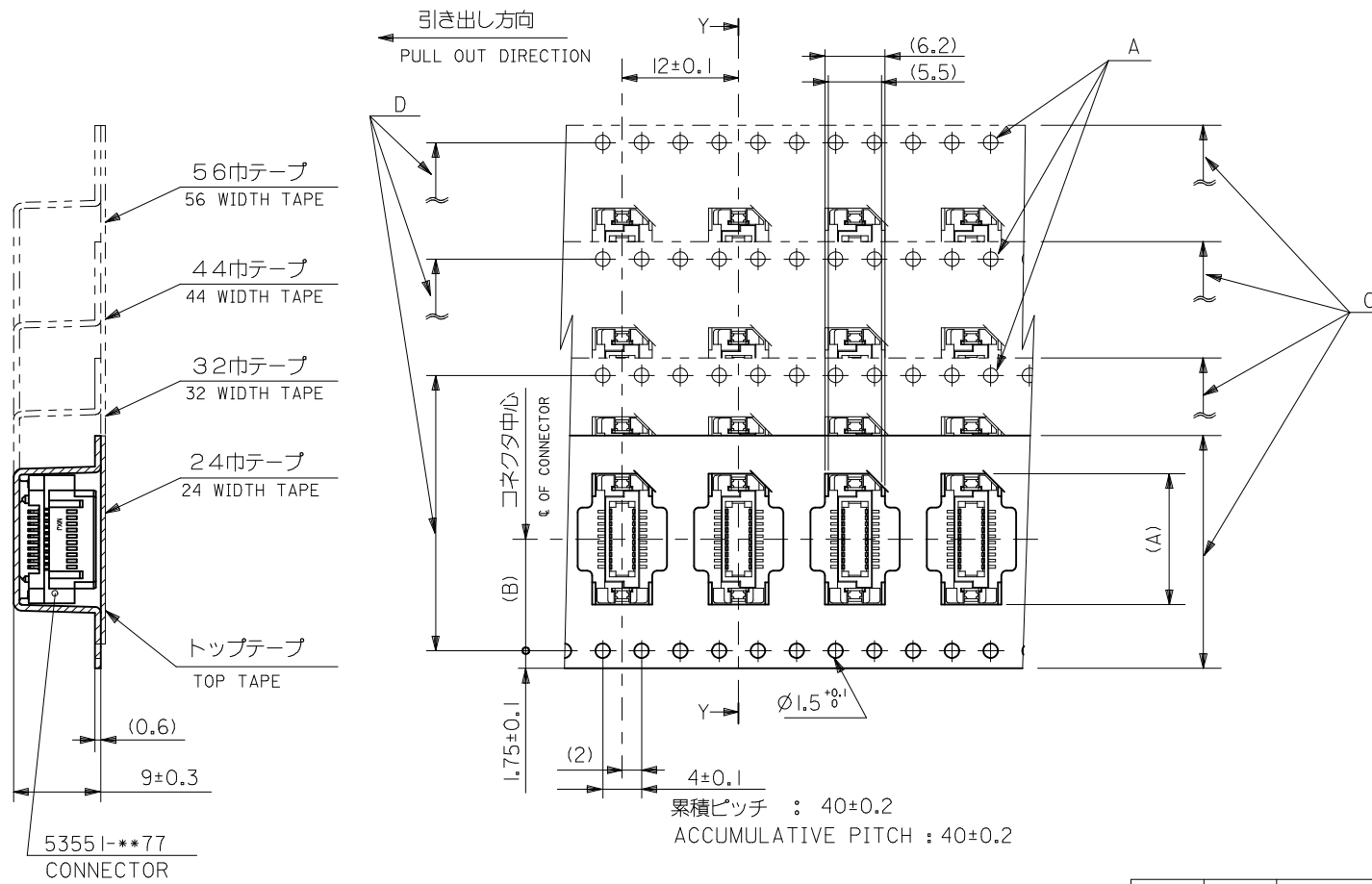

44.4	40.4	44 <sup>+0.3</sup>	20.2	29.4	53551-0778	70
				26.2	53551-0678	60
32.4	28.4	32 <sup>+0.3</sup>	14.2	19.9	53551-0478	40
E	D	C	キャリアテープ幅 CARRIER TAPE WIDTH	B	A	MATERIAL NO. 極数 NO. OF CTS.
MODEL NO.						53551-005

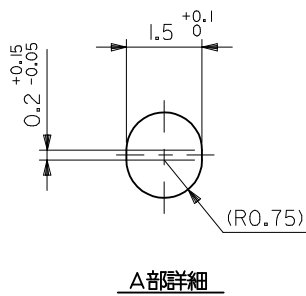

REVISED EC NO: J2009-0433 DRWN: MAKURAA 2008/11/26 CHKD: T. HARIYAMA 2008/11/26 APPR: NUKITA 2009/01/08	GENERAL TOLERANCES (UNLESS SPECIFIED)		DIMENSION STYLE MM ONLY	SCALE ---	DESIGN UNITS METRIC	THIRD ANGLE PROJECTION
	10 UNDER	± ---	DRAWN BY S. SHIMABUKUR	DATE '04/3/30	TITLE 53551-**-77 TAPING PACKAGE SHEET 2 OF 2	
	10 OVER 30 UNDER	± ---	CHECKED BY K. TOJO	DATE '04/3/30	MOLEX INCORPORATED	
	30 OVER	± ---	APPROVED BY M. SASAO	DATE '04/3/30	DOCUMENT NO. SD-53551-005	SHEET NO. 2 OF 3
REV	DESCRIPTION	ANGULAR ± --- °	MATERIAL NO.	SEE TABLE		
DRAFT WHERE APPLICABLE MUST REMAIN WITHIN DIMENSIONS		SIZE A3	THIS DRAWING CONTAINS INFORMATION THAT IS PROPRIETARY TO MOLEX INCORPORATED AND SHOULD NOT BE USED WITHOUT WRITTEN PERMISSION			

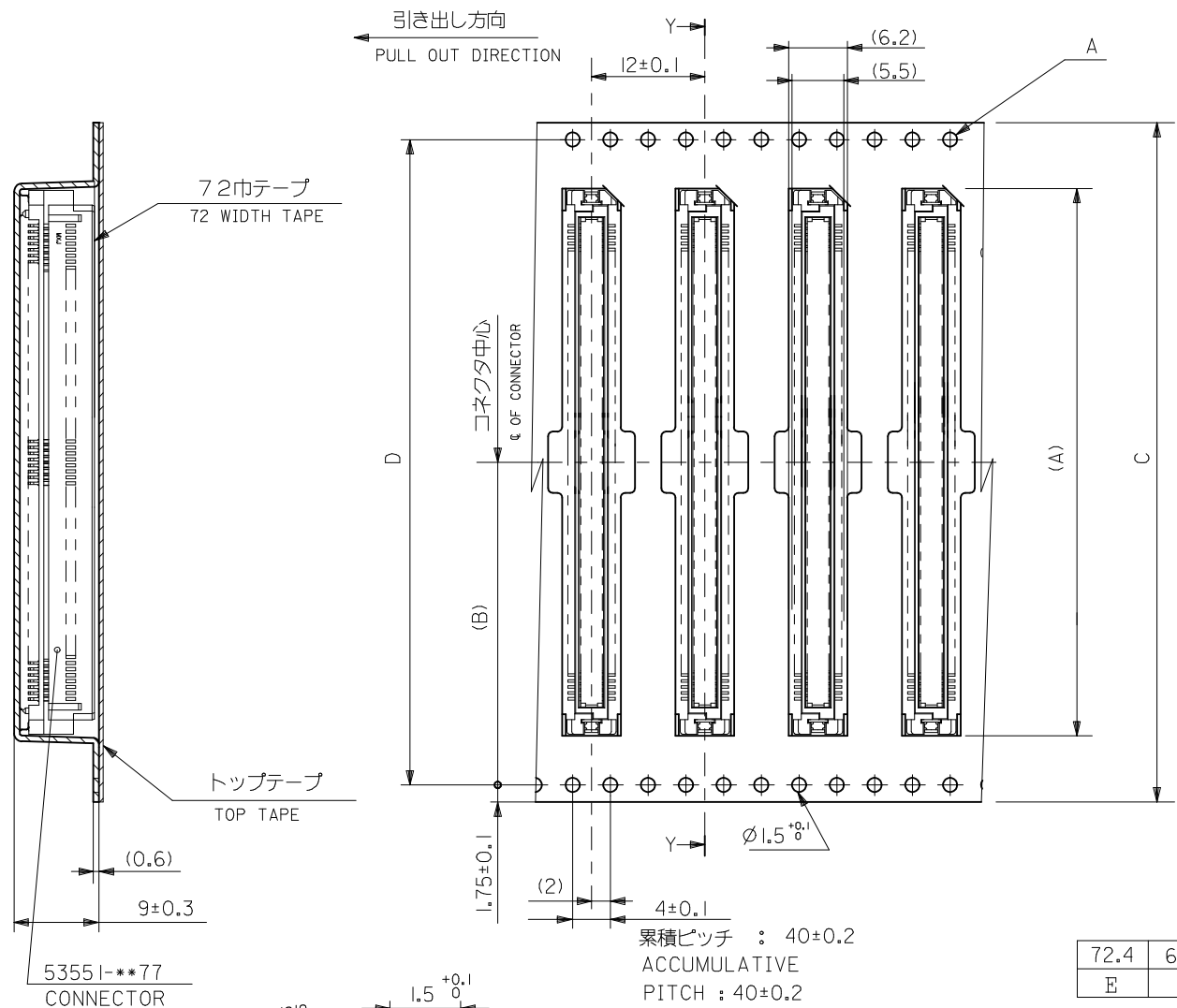

断面 Y-Y  
SECTION Y-Y

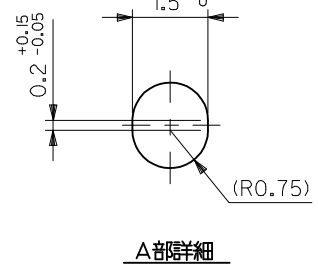

REVISED EC NO: J2009-0433 DRWN: MAKURAA 2008/11/26 CHKD: T. HARUYAMA 2008/11/26 APPR: NUKITA 2009/01/08	GENERAL TOLERANCES (UNLESS SPECIFIED)	
	10 UNDER	± ---
	10 OVER 30 UNDER	± ---
	30 OVER	± ---
	ANGULAR	± --- °
	DRAFT WHERE APPLICABLE MUST REMAIN WITHIN DIMENSIONS	

72.4	68.4	72 ±0.3	34.2	51.6	53551-1478	140
E	D	C キャリアテープ幅 CARRIER TAPE WIDTH	(B)	(A)	MATERIAL. NO.	極数 NO. OF CXTS.
					MODEL NO.	53551-**78

DIMENSION STYLE MM ONLY		SCALE ---	DESIGN UNITS METRIC	THIRD ANGLE PROJECTION	
DRAWN BY H. SHIMABUKUR	DATE	TITLE 53551-**77 TAPING PACKAGE -LEAD FREE-			
CHECKED BY K. TOJO	DATE	MOLEX INCORPORATED			
APPROVED BY M. SASAO	DATE				
MATERIAL NO.	DOCUMENT NO.	SEE TABLE		SD-53551-005	SHEET NO. 3 OF 3
THIS DRAWING CONTAINS INFORMATION THAT IS PROPRIETARY TO MOLEX INCORPORATED AND SHOULD NOT BE USED WITHOUT WRITTEN PERMISSION					