

Description

Create a designated ESD grounding point on panels, racks, cabinets etc. The EBP kit has a 10mm stud connection which is then electrically bonded to the mounting or earth by the user.

- Mounting plate 25 x 35 mm in Yellow ABS
- Clearly indicates "ESD BONDING POINT " Per IEC 61340-5-2 Visible, unambiguous and easily recognized marking yellow on black colours
- 10mm snap stud Per IEC 61340-5-2 The use of mating snap connectors and specialized miniature sockets is recommended to prevent the EBP system being inadvertently connected to live circuits which may cause damage or safety problems

This kit comes assembled and includes the following parts:

- 10mm Press Stud
- M5 Ring Terminal
- Vinyl Plate
- M3 Nut
- Plastic Shoulder Washer
- M3 Screw
- Shakerproof Washer
- M3 Washer

5.3.2 EPA ground facility

All forms of EPA need an earth facility and common point grounding system. In many EPA this will be the mains protective earth facility. Throughout the EPA for connections to all working surfaces, the floor and the earth bonding points for wrist straps. Within any single EPA, only one EPA ground facility is permitted.

5.3.3EPA ground bonding point (EBP)

An EBP is required to allow anyone working in or visiting an EPA to connect the wrist strap (see IEC 61340-5-2 5.2.7) to ground.

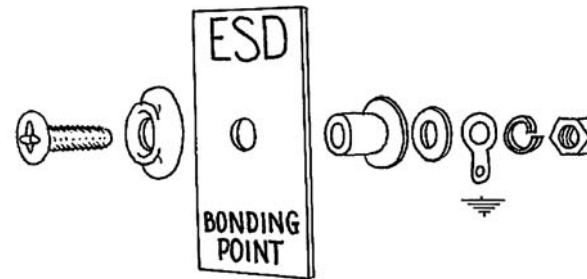
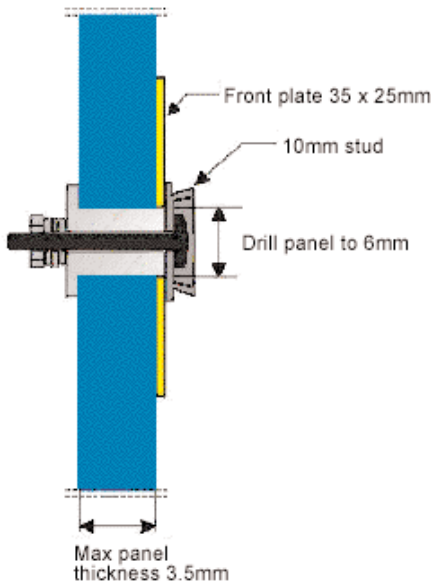

ITEM	DESCRIPTION
231105	EBP Kit, 10mm Stud (No Wire)



Made in Britain

Vermason

EBP Kit, 10mm Stud (No Wire)

VERMASON
 1 AVENUE ONE, LETCHWORTH, HERTS, SG6 2HB UK
 PHONE: +44 (0) 1462-672005, FAX: +44 (0) 1462-670440
 E-MAIL: Service@Vermason.co.uk, INTERNET: Vermason.co.uk

Drawing Number
231105

DATE:
 December 2007