

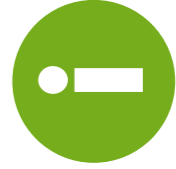

# ZANUSSI

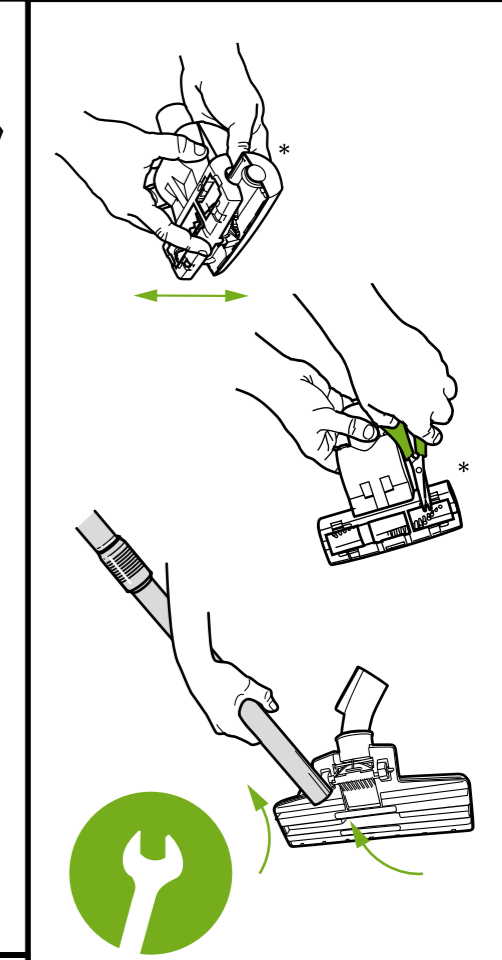
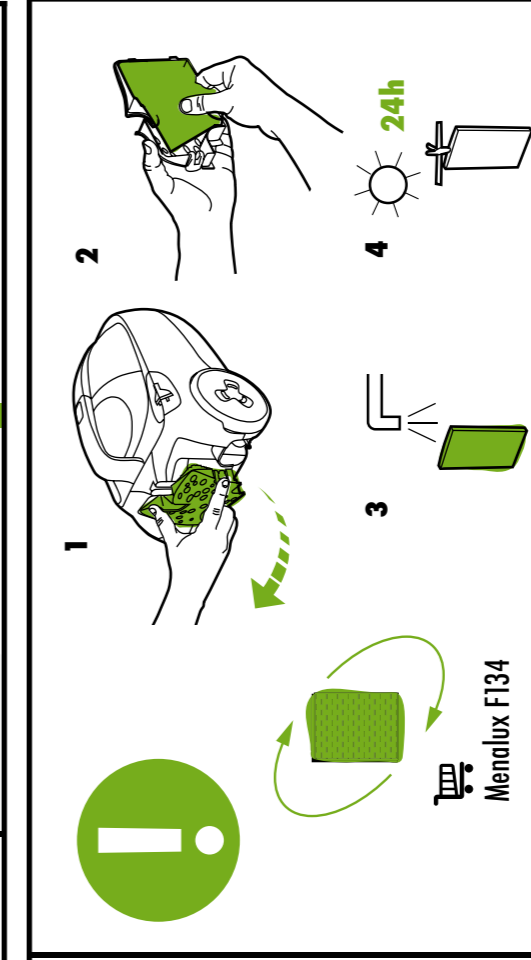
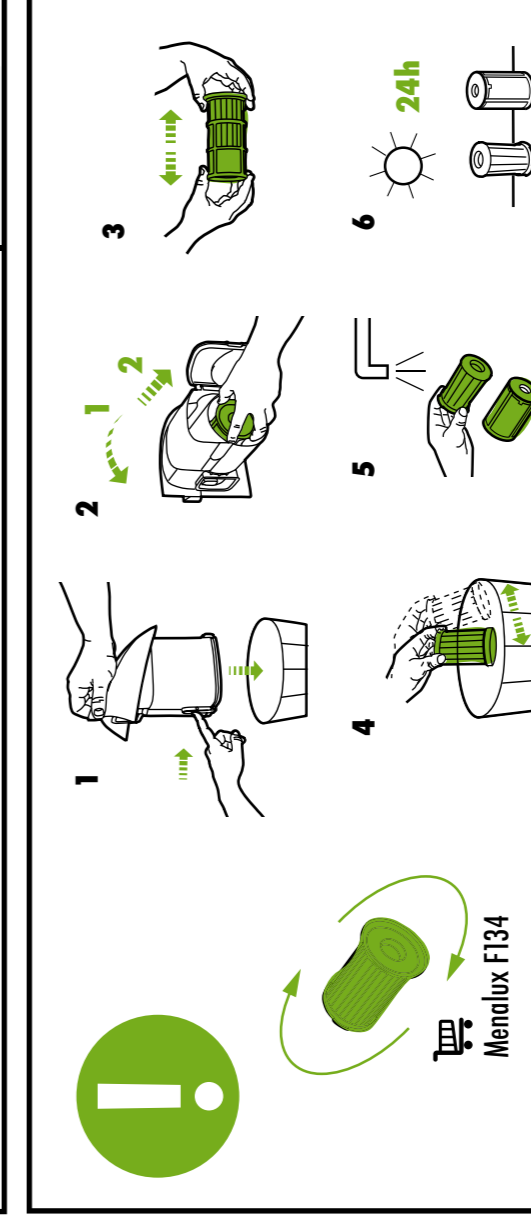
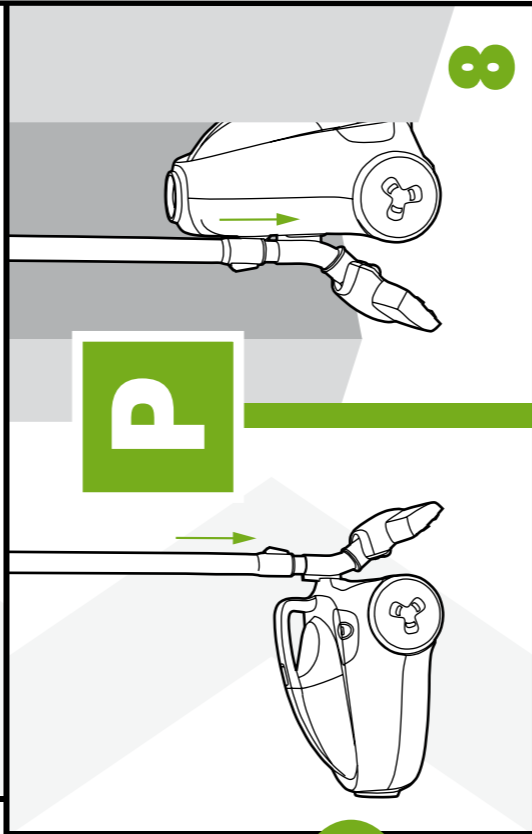
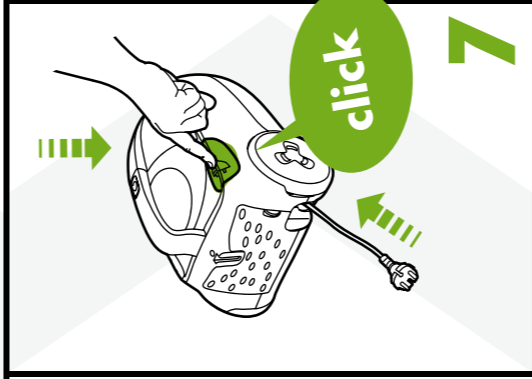
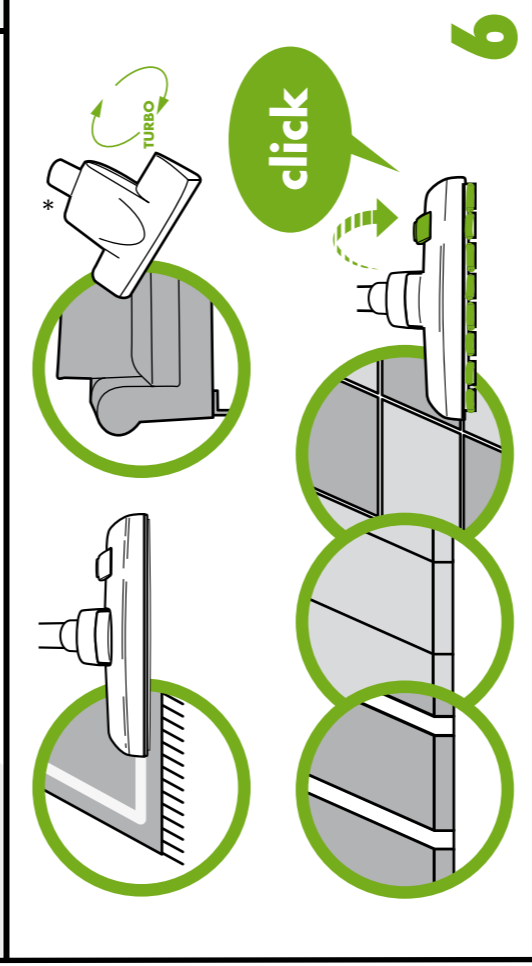
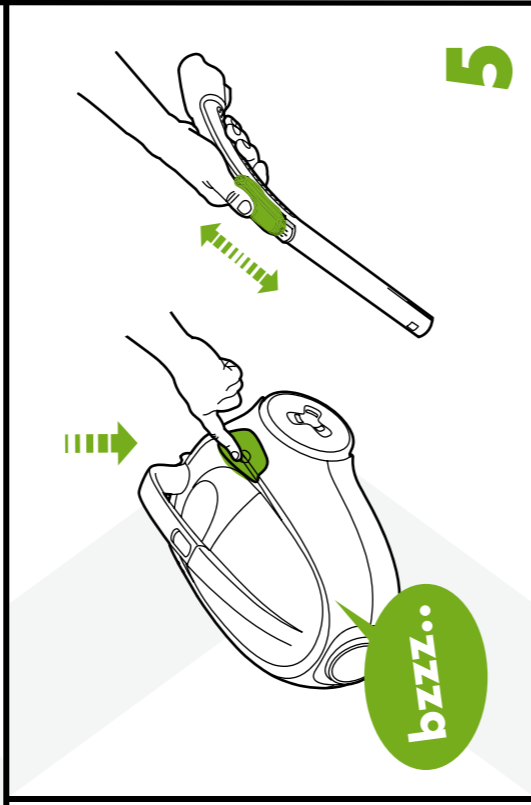
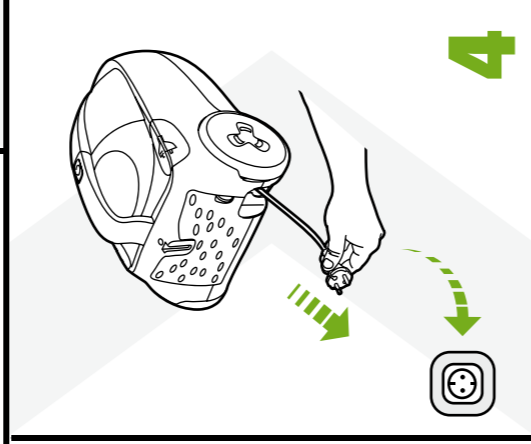
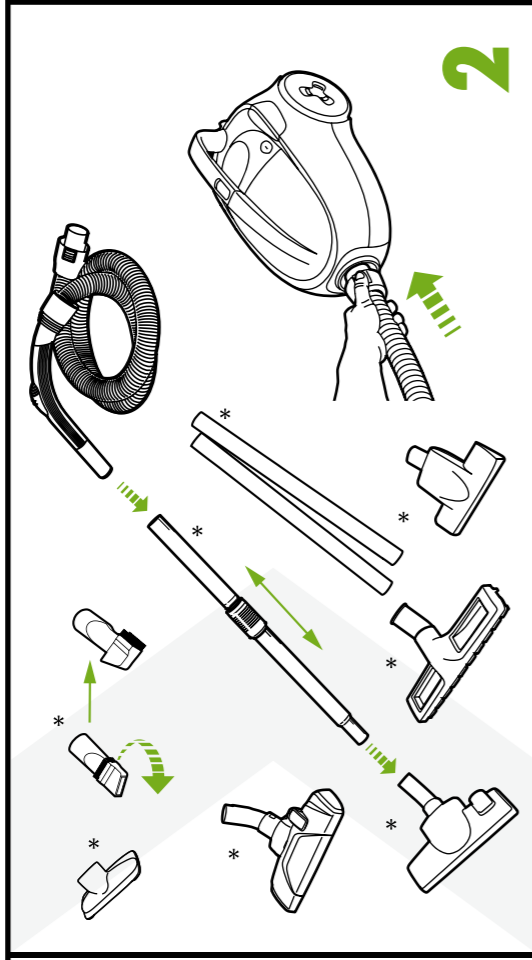
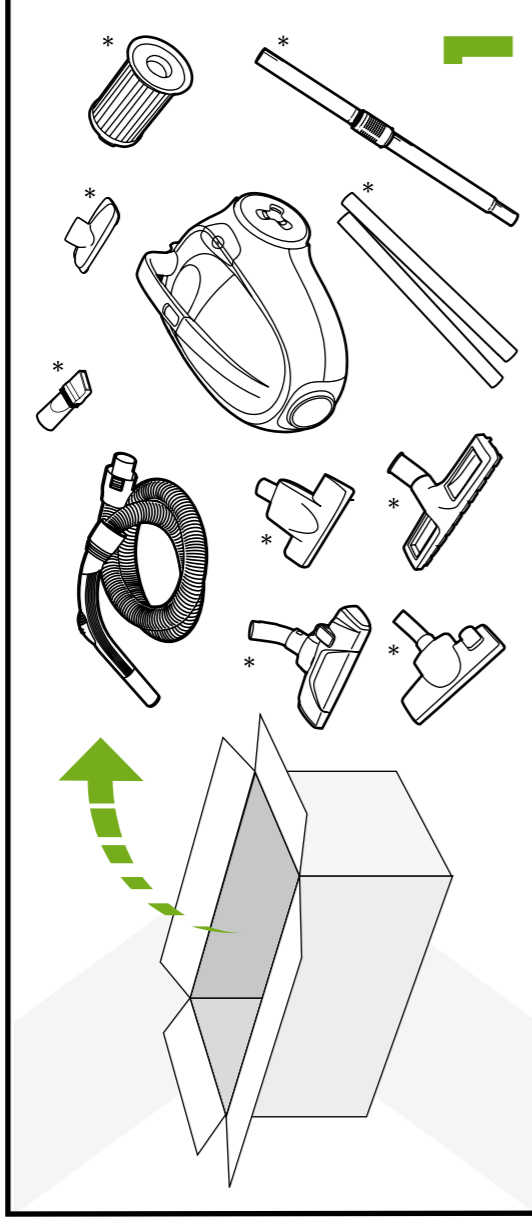

[www.zanussi.com](http://www.zanussi.com)

### Safety requirement and warning

This appliance can be used by children aged from 8 years and above and persons with reduced physical, sensory or mental capabilities or lack of experience and knowledge if they have been given supervision or instruction concerning use of the appliance in a safe way and understand the hazards involved.

**WARNING:** Turbo nozzles\* have a rotating brush in which parts may become entrapped. Please use them with caution and only on intended surfaces. Please turn the vacuum cleaner off before removing entrapped parts or cleaning the brush.

Children should be supervised to ensure that they do not play with the appliance.

Cleaning and maintenance shall not be made by children without supervision.

Always disconnect the plug from the mains before cleaning or maintaining the appliance.

Never use the vacuum cleaner without its filters.

### Caution

This appliance contains electrical connections:

- Never vacuum any liquid
- Do not immerse in any liquid for cleaning
- The hose should be checked regularly and must not be used if damaged.

The above can cause serious damage to the motor, which is not covered by the warranty.

This vacuum cleaner is for domestic use only.

### Never use vacuum cleaner

- Close to flammable gases, etc.
- On sharp objects
- On hot or cold cinders, lit cigarette butts, etc.
- On fine dust, for instance plaster, concrete, flour.

### Power cord precautions

- Regularly check that the plug and cord are not damaged. Never use the vacuum cleaner if the cord is damaged.
- If the cord is damaged, it must be replaced only by an authorized Zanussi service centre in order to avoid a hazard. Damage to the vacuum cleaner's cord is not covered by the warranty.
- Never pull or lift the vacuum cleaner by the cord.

All servicing and repairs must be performed by an authorized Zanussi service centre. Store the vacuum cleaner in a dry place.

### Consumer information and sustainability policy

Zanussi declines all responsibility for all damages arising from any improper use of the appliance or in cases of tampering with the appliance. For more details of warranty and consumers' contacts see the Warranty Booklet in the packaging

If you have any comments on the cleaner or the Operating Instructions manual please e-mail us at [floorcare@zanussi.com](mailto:floorcare@zanussi.com).

### Sustainability policy

This product is designed with the environment in mind. All plastic parts are marked for recycling purposes.

For details see our website: [www.zanussi.com](http://www.zanussi.com)

The packaging material is chosen to be environmentally friendly and can be recycled.

Recycle the materials with the symbol . Put the packaging in applicable containers to recycle it.

Help protect the environment and human health and to recycle waste of electrical and electronic appliances. Do not dispose appliances marked with the symbol  with the household waste. Return the product to your local recycling facility or contact your municipal office.

\* Certain models only.

## SAVE THESE INSTRUCTIONS

### BEFORE YOU START

#### CHECK THE VOLTAGE

First check the voltage shown on the data plate (see rear view) to make sure that the cleaner is of the correct voltage for your electricity supply. If it is not, do not use the cleaner but refer back to your dealer.

#### CONNECTING TO YOUR ELECTRICITY SUPPLY

Permanently connected to the cleaner is a mains supply (2-core) cable fitted with a non-rewirable plug incorporating a 13A fuse.

In the event the fuse requires replacement, the fuse cover should be removed using a small screwdriver. The old fuse **MUST** be replaced by a 13A ASTA approved BS1362 fuse or a BSI approved fuse. The cover must be replaced before the plug is used again. In the event of loss of the fuse cover, replacements can be obtained from your Electrolux Retailers and must be of the same colour as indicated by the coloured insert on the base of the plug.

If difficulty is experienced in obtaining a replacement, contact ZANUSSI on +44 (0) 8445 612 612. Calls to this number will be charged at 5p per minute at all times from a BT Landline.

**Under no circumstances should the plug be used without a correct fuse cover fitted.**

If the plug that is fitted to your appliance is not suitable for your socket outlet, it must be cut off and the appropriate plug fitted.

Remove the fuse from the cut off plug.

The cut off plug should then be disposed of to prevent the hazard of shocks in case it should be plugged into a 13 amp socket in another part of your home.

The wires in the mains cable of this appliance are coloured in accordance with the following code: **Blue: Neutral. Brown: Live.**

As the colours of the wires in the mains cable of this appliance may not correspond with the coloured markings identifying the terminals in your plug, proceed as follows:

The wire that is coloured blue must be connected to the terminal that is marked with the letter N or coloured black.

The wire that is coloured brown must be connected to the terminal that is marked with the letter L or coloured red.

If using a three-pin plug, do not make any connection to the terminal marked with the letter E or by the earth symbol, or coloured green or green-and-yellow. This cleaner is double insulated and no earth connection is necessary.

It is in your interest to ensure that the plug is correctly attached to the mains cable. In case of doubt, have it done by a qualified electrician, as ZANUSSI cannot regard the repair of faults on the plug connection as a service that can be given free of charge under the terms of the guarantee.

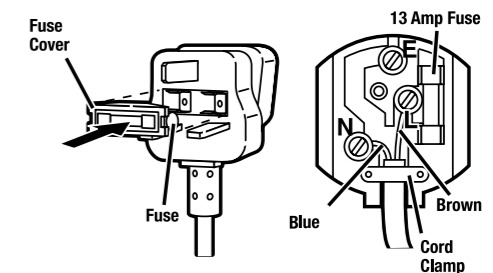

Thank you for purchasing your new vacuum cleaner. If in the unlikely event you experience any problems with this product,

**RATHER THAN TAKING IT BACK TO THE SHOP**

Please telephone the Customer Helpline

**+44 (0) 8445 612 612**

Calls to this number will be charged at 5p per minute at all times from a BT landline. Lines are open Monday to Friday 8.30am to 5pm and Saturday morning 9am until 12.30pm R.O.I. 0818 543000\*\* (opt 3) \*\*Calls cost up to 9 cents per minute from a standard Eire Com landline. \*Mobile and other providers' charges may vary.

Should any faults occur with your cleaner during the first 12 months, please telephone the Customer Helpline on the number above

- ✓ Something missing or broken?
- ✓ Need more help?
- ✓ Don't understand the instructions? Please Telephone the Customer Helpline on the number above

(This does not affect your statutory rights)