

THIS DRAWING IS UNPUBLISHED. RELEASED FOR PUBLICATION
 © COPYRIGHT - By - ALL RIGHTS RESERVED.

DESIGNED FOR USE WITH
 .085 DIA S.R. CABLE
 CABLE ENTRY DIAMETER
 MINIMUM

CONTACT	.0215
HOUSING	.088

LOC	DIST	REVISIONS			
P	LTR	DESCRIPTION	DATE	DWN	APVD
	B1	REV PER ECR-14-011093	23JUL14	AM	MY

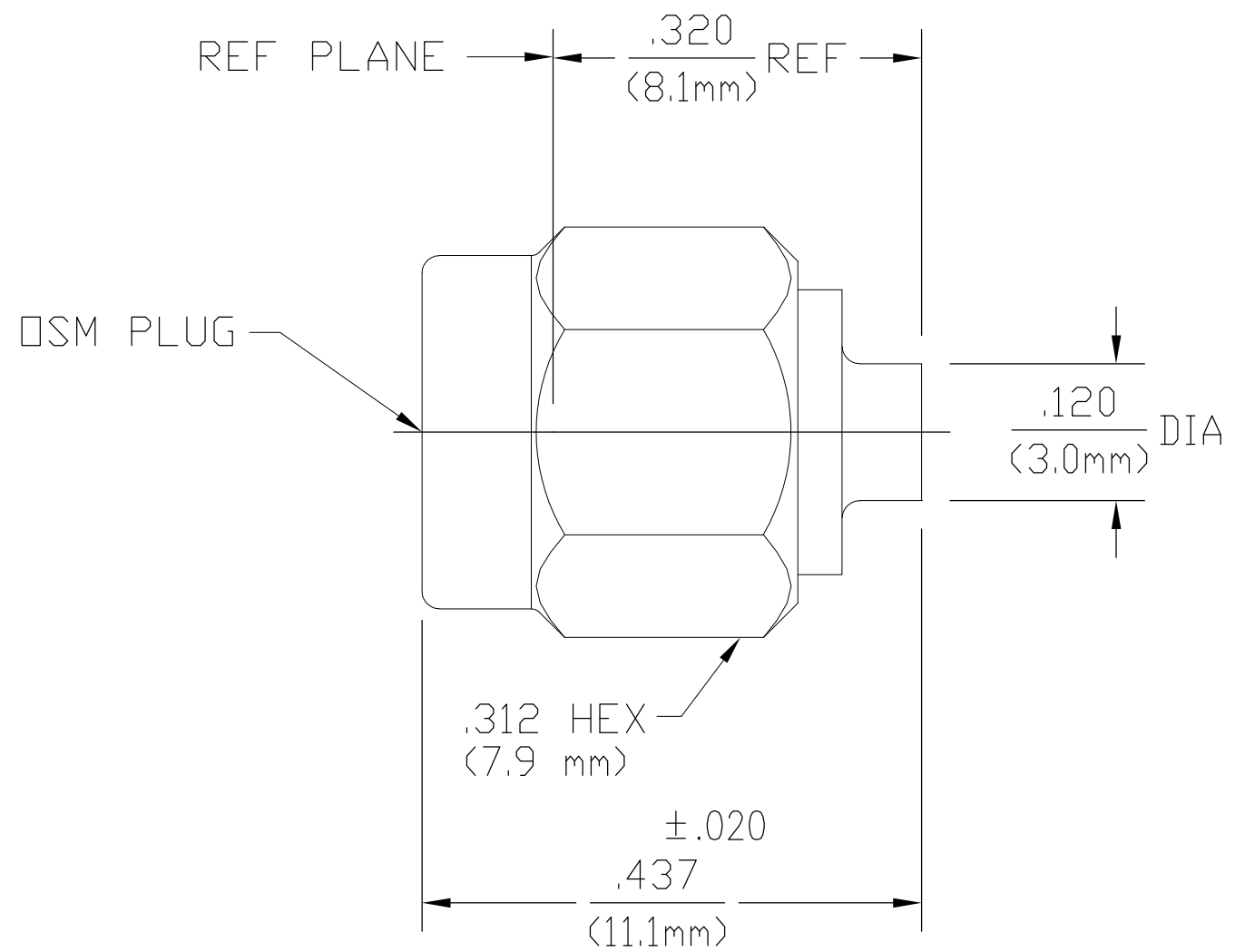

1050548-1
 PART NUMBER

COMPONENT	MATERIAL	FINISH
HOUSING	STAINLESS STEEL PER ASTM-A484 AND ASTM-A582, TYPE 303	GOLD PLATE PER MIL-G-45204 OVER NICKEL PLATE PER QQ-N-290
COUPLING NUT	STAINLESS STEEL PER ASTM-A484 AND ASTM-A582, TYPE 303	PASSIVATE PER ASTM-A380
DIELECTRIC	TFE FLUOROCARBON PER ASTM-D-1457	N/A
CENTER CONTACT	BERYLLIUM COPPER PER ASTM B 196, ALLOY C17300, CONDITION H OR BRASS PER ASTM-B-16	GOLD PLATE PER MIL-G-45204 OVER NICKEL PLATE PER QQ-N-290 OVER COPPER PLATE PER MIL-C-14550
RETAINING RING	BERYLLIUM COPPER PER ASTM B 194, ALLOY C17200, CONDITION H	N/A
GASKET	SILICONE RUBBER PER ZZ-R-765	N/A

ELECTRICAL	MECHANICAL	ENVIRONMENTAL
Nominal Impedance (Ohms) 50	Interface Dimensions MIL-STD-348A Fig. 310.1	TEMPERATURE RATING -65°C TO 105°C
Frequency Range (GHz) DC to 18.0	Recommended Mating Torque 7 to 10 in-LBs	Vibration MIL-STD-202, Method 204, Condition D
Volt Rating (VRMS MAX) @ Sea Level 335	Mating Characteristics: Insertion (MAX Lbs) N/A	Shock MIL-STD-202, Method 213, Condition I
VSWR 1.07 + .008f(GHz)	Withdrawal (MIN Oz) N/A	Thermal Shock MIL-STD-202, Method 107, Condition B, EXCEPT HIGH TEMP 115°C
Insertion Loss (dB MAX) .03 √f(GHz)	Force to Engage and Disengage (In-Lbs MAX) 2.0	Moisture Resistance MIL-STD-202, Method 106
RF Leakage (dB MIN) -[90-f(GHz)]	Center Contact Captivation Axial (Lbs) N/A	Corrosion - MIL-STD-202, Method 101, Condition B, 5% salt spray
Corona, 70,000 Ft (VRMS MIN) 250	Radial (In-Oz) N/A	
Dielectric Withstanding Voltage (VRMS MIN) @ Sea Level 1000	Cable Retention Axial Force (Lbs) 30	
Contact Resistance (Milliohms MAX) Center Contact 3.0	Torque (In-Oz) 16	
Outer Contact 2.0	Weight (Grams) T.B.D.	
Cable to Housing 0.5		
RF High Potential @ Sea Level (VRMS MIN @ 5 MHz) 670		
I.R.(Megohms MIN) 5,000		

THIS DRAWING IS A CONTROLLED DOCUMENT.

DWN JPD 9/1/76	TE Connectivity
CHK -	
APVD RMF 9/13/76	NAME OSM STRAIGHT CABLE PLUG DIRECT SOLDER ATTACHMENT
PRODUCT SPEC -	
APPLICATION SPEC -	SIZE A2 CAGE CODE 00779 DRAWING NO C=1050548 RESTRICTED TO -
MATERIAL - FINISH -	WEIGHT - SCALE 5:1 SHEET 1 of 1 REV B1

CUSTOMER DRAWING