

80T-150U Universal Temperature Probe

Instruction Sheet

Introduction

The Model 80T-150U Universal Temperature Probe is a self-contained temperature-to voltage converter. The probe is designed to provide a direct temperature reading when it is connected to any high impedance DMM that is capable of 1 mV resolution and at least a 300-count full scale readout capability. Output is 1 mV per degree (Celsius or Fahrenheit). Two switch-selected temperature output scalings are provided: -50 to +150°C or -58 to +302°F. The probe will stand off 60V dc or 30V ac rms (42.4V peak).

The unit is housed in two separate but attached assemblies: a temperature probe and a temperature-to-voltage converter. The probe contains the temperature-sensing element and is electrically connected to the temperature-to-voltage converter through a 46-inch shielded cable. A three-position switch on the converter acts as a power switch and is used for selecting Celsius or Fahrenheit scaling for the output. Two banana plugs with standard 0.75-inch spacing are provided for connecting the 80T-150U to the DMM.

Operating power for the 80T-150U is derived from a standard 9V battery. Typically, an alkaline battery provides more than 1600 hours of continuous operation before replacement is necessary. An OFF switch is provided on the temperature-to-voltage converter to allow battery conservation when the unit is not in use. In addition, the OFF position of the power switch allows the battery condition to be determined via the external DMM.

Temperature is measured by exposing the probe tip directly to the material to be measured (non-corrosive liquid, gas, or solid). A direct temperature reading is displayed on the DMM.

Specifications

The 80T-150U will achieve rated accuracy when it is used with any 0.25% DMM that has an input impedance of $\geq 1 \text{ M}\Omega$.

Electrical

Measurement Range: (See Probe Limitations)
-50 to +150 degrees Celsius
-58 to +302 degrees Fahrenheit

Accuracy: (Applies for one year after purchase or calibration)

AMBIENT °C	ACCURACY
+15 to +35°C	$\pm 1^\circ\text{C}$ from 0 to +100°C, decreasing linearly to $\pm 3^\circ\text{C}$ at -50 and +150°C
0 to 15°C and +35 to +50°C	$\pm 2^\circ\text{C}$ from 0 to +100°C, decreasing linearly to $\pm 4^\circ\text{C}$ at -50 and +150°C
AMBIENT °F	ACCURACY
+59 to +95°F	$\pm 1.8^\circ\text{F}$ from +32 to +212°F, decreasing linearly to $\pm 5.4^\circ\text{F}$ at -58 and 302°F
+32 to +59 °F and +95 to +122 °F	$\pm 3.6^\circ\text{F}$ from +32 to +212°F, decreasing linearly to $\pm 7.2^\circ\text{F}$ at -58 and 302°F

Sensitivity (80T-150U output): 1 mV dc / °C or °F

Voltage Standoff: 60V dc or 30V ac rms (42.4V peak)

Settling Time: 5.5 seconds to settle within 2° for a 50° change

RF Field: Exposure to an RF field interferes significantly with this module's capacity to accurately measure temperature. The

interference is temporary and the module suffers no harm when exposed to an RF field of 3 V/m. Accurate temperature measurement capability is completely restored when the module is removed from the RF field.

Common sources of RF fields are handheld two-way radios and cellular telephones. If such a source is suspected of interfering with this module, either turn off the transmitter or increase the separation between the transmitter and the module.

Environmental

Ambient Operating Range for Temperature Module: 0 to +50°C (+32 to +122°F)

Maximum Temperature Probe Body and Cable: +70°C (160°F)
See Probe Limitations

Minimum Temperature Probe Body and Cable:
Minimum Operating Temperature for Cable: -12°C (10°F)
Minimum Operating Temperature for Probe Body: -40°C (-40°F) See Probe Limitations

Storage Temperature for Unit: -40 to +70°C (-40 to +160°F)

Humidity: 0% to 90% (0°C to 35°C)
0% to 70% (35°C to 50°C) (noncondensing)

Altitude: Operating: $\leq 10,000$ feet
Storage: $\leq 50,000$ feet

Application Force: 15 pounds maximum (probe tip to measured surface)

General

Weight: 5.7 ounces, 161.5 grams

Overall Length: 53.8 inches, 1.36 meters

Battery: Standard 9V battery (NEDA #1604,6F22,006P)

Battery Life: 1600+ hours, typical (Alkaline Battery), 6.5V minimum

Output Termination: Standard 0.75-inch spaced double banana plug

Probe Material: Glass-filled valox

Probe Size: 0.6" maximum diameter

Tip Material: Aluminum

Tip Size: 0/07" to 0.08" diameter, 30% convexed

Operating Notes

The following paragraphs are intended to familiarize the operator with the 80T-150U. The operator should read these paragraphs before attempting to operate the probe.

Probe Limitations

The 80T-150U probe is constructed of a highly durable plastic and is suitable for measuring the temperature of liquids, gases, and solid surfaces up to 150°C. When measuring temperature, observe the following precautions to prevent damage to the probe:

- Do not expose the probe end (probe tip plus about 2 inches of the probe body) to temperatures exceeding +150°C (302°F). The remainder of the probe body should not be exposed to temperatures above +70°C (160°F).

- Do not expose the probe end (probe tip plus about 2 inches of the probe body) to temperatures below -50°C (-58°F). The remainder of the probe body should not be exposed to temperatures below -40°C (-40°F).
- For liquid measurements, recommended applications range from water, lubricants, and fuels to most solvents. Liquids as shallow as 1/2 inch can be measured since the temperature sensor is in the probe tip.

Warning

To avoid electrical shock, do not use this instrument when voltages exceeding 60V dc or 30V ac rms (42.4V peak) are present. The probe tip is electrically connected to the output terminals.

Caution

Long-term exposure of the probe to corrosive environments will result in pitting and deterioration of the aluminum probe tip.

- Connect the banana plugs on the 80T-150U to the input terminals of a high impedance DMM. Observe polarity.
- Select a dc voltage range that will provide at least 1 mV resolution (1 mV/degree) and a full scale readout that will encompass the expected temperature. The 2V range of a 3 1/2-digit DMM is adequate. Ignore readings of less than 1° when a more sensitive DMM is used.
- Set the 80T-150U power switch to $^{\circ}\text{C}$ or $^{\circ}\text{F}$, and energize the DMM.
- Firmly touch the probe tip to the surface to be measured, or expose it to a liquid or gas. The DMM will display the temperature in degrees. Vary the probe angle and pressure when measuring solid surface temperatures. The highest stabilized reading will be the most accurate. (See the following measuring technique.)

Caution

The force exerted on the probe tip should not exceed 15 pounds.

Error Sources

When the probe tip is applied to a solid surface, it draws or sinks heat from the surface. Therefore, if the measured surface has a low mass (e.g., a transistor case), the indicated temperature may be lower than the actual temperature.

Similarly, a steady-state error or gradient exists between the measured surface and the sensing device in the probe tip. This is due to the flow of heat from the measurement surface to the probe body. The effect of the steady-state error increases as the differential between ambient and surface temperature increases.

To determine the actual surface temperature of a device, both the heat-sinking and steady-state errors must be considered. The correction curve given in Figure 1 approximates the effect of both error sources on TO-3, TO-5, and TO-18 transistor cases.

RF signals applied to the 80T-150U probe tip can also cause errors in temperature measurement. Figure 2 defines the rf signal limits that can be tolerated without degrading measurement accuracy.

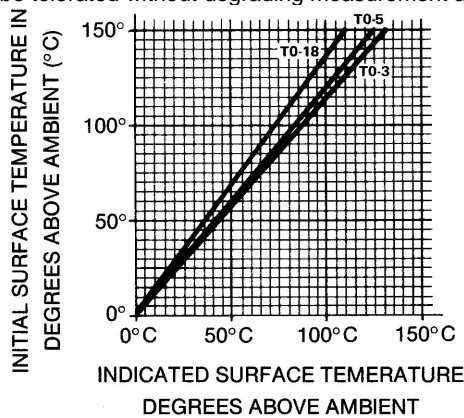

F1.eps

Figure 1. Initial Case Temperature Above Ambient vs Meter Reading Above Ambient

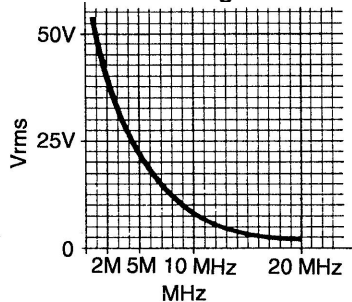

F2.eps

Figure 2. Maximum Signal RF Limits (V_{rms}) at Probe Tip

Operation

Use the following procedure to operate the 80T-150U probe:

Measuring Technique

Here are some suggestions for improving the accuracy of your temperature measurements:

- When measuring higher than ambient temperatures, adjust the connection between the probe and the surface until you get the highest temperature reading.
- When measuring lower than ambient temperatures, adjust the connection between the probe and the surface until you get the lowest temperature reading.
- When measuring near ambient temperatures, make the reading when the multimeter readout is most stable.

Theory Of Operation

The Model 80T-150U uses the negative temperature coefficient of a semiconductor (P-N) junction to measure temperature. The PN junction is thermally integrated into the probe tip and comprises one leg of a bridge circuit as shown in the simplified circuit diagram of Figure 3. One 9V battery is used to power both the bridge circuit and operational amplifier U1. Since the bridge must be balanced to provide 0°C and 0°F indications, separate range or temperature scale resistors R7 and R6 are included in the bridge circuit. When R6 and R2 are shorted by S1, the $^{\circ}\text{C}$ scale is selected and the bridge is calibrated by R3 to null at 0°C . Conversely, when S1 is open, the 0°F scale is selected, and the bridge is calibrated by R2 to null at 0°F . Deviations above and below 0° provide a bridge output of approximately $2.45 \text{ mV}/^{\circ}\text{C}$.

Operational amplifier U1 is used to measure the bridge output and scale it to a $1 \text{ mV}/\text{degree}$ signal. Since the $^{\circ}\text{C}$ and the $^{\circ}\text{F}$ scale are sloped differently, the scale for U1 must be matched with the scale selected for the bridge circuit. Shorting resistors R15 and R18 selects the $^{\circ}\text{C}$ scale. Conversely, when S1 is open, the $^{\circ}\text{F}$ scale is selected. Resistor R4 calibrates both scales.

The output voltage used to drive the external voltmeter is taken from the output of U1 (P2) and the reference side of the bridge (P1). Since U1 is operating as an inverting amplifier, its output is used as the low input to the voltmeter. This enables the voltmeter to display an increase in temperature as an increase in voltage.

General Maintenance

Access Information

The battery and the calibration pots are located on the interior of the temperature-to-voltage converter assembly. Access to these locations is accomplished by removing the screw from the bottom side of the assembly and removing the top of the plastic box.

Battery Condition Test

1. Set the power switch to the OFF position.
2. Connect the 80T-150U to the DMM.
3. Set the DMM to the 200 or 400 mV dc range.
4. Read the battery test voltage on the DMM or test instrument. For DMMs with 10 MΩ input impedance, a minimum reading of 100 mV is acceptable. For test instruments with 1 MΩ input impedances, such as ScopeMeter®, a minimum reading of 75 mV is acceptable. With these minimum readings, approximately 100 hours of battery life remain.

Battery Replacement

Warning

To avoid electrical shock, remove the probe from the measurement surface before opening the case. Totally reassemble the instrument before attempting to use it.

1. Set the power switch to the OFF position.
2. Disconnect the 80T-150U from the DMM.
3. Turn the 80T-150U so the power switch is facing down. Remove the single screw located between the banana plugs.
4. Grasp one case half in each hand. Pull the two halves apart, beginning at the end with the banana plugs.
5. Remove and replace the battery.
6. Reassemble the 80T-150U as follows. Mate the two case halves at the end where the cable enters the case, then "hinge" the two halves together. Replace the case screw, being careful not to pinch the probe cable or battery wires.

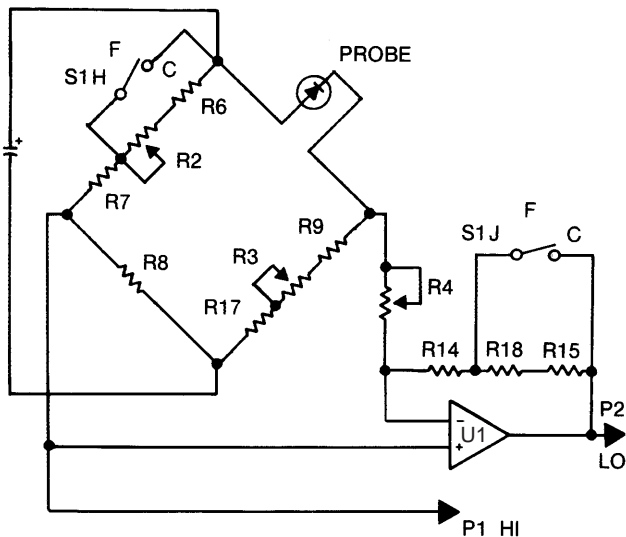

Figure 3. Simplified Circuit Diagram

F3.eps

Performance Test

Complete the calibration procedure without opening the temperature-to-voltage converter assembly and without making any calibration adjustments. Observe the readings given in [brackets]. Other readings are for calibration only.

Calibration

The calibration cycle of one year is recommended to maintain the unit within the specifications given earlier. The equipment required for calibration is listed in the table following the calibration procedure.

Note

Values given in brackets apply to the Performance Test.

Perform the following steps to calibrate the 80T-150U:

1. Access the interior of the temperature-to-voltage converter by removing the bottom case screw and separating the case halves.
2. Connect the 80T-150U to a DVM with 10 μV resolution, and select mV dc range.
3. Select the °C position of the switch. Immerse the probe tip 2 inches into a mercury thermometer monitored 0°C bath, and allow 60 seconds for the readings to stabilize.
4. Adjust R3 (see Figure 4) to obtain the following reading: 0.00 ±0.05 mV dc [0 ±0.2 mV dc]
5. Select the °F position of the switch, and adjust R2 to obtain the following reading: 32.0 ±0.1 mV dc [32.0 ±0.4 mV dc]
6. Select the °C position, and move the probe tip to a 70°C to 90°C bath and again allow the readings to stabilize.
7. Adjust R4 to obtain a DVM reading that agrees with the bath temperature (BT) as monitored by a mercury thermometer. °C BT ±0.05 mV dc [BT ±0.2 mV dc]
8. Select the °F position, and verify that the output is within ±4 mV dc of the bath thermometer reading. If necessary, change the DVM range to obtain an on-scale reading.
9. Return the probe tip to the 0°C bath and check the output. If readjustment is necessary, repeat steps 4 through 8 until readings can be obtained without adjustment.
10. Set the 80T-150U switch to the OFF position, and remove the 80T-150U from the DVM.
11. Reassemble the 80T-150U.
12. The 80T-150U is now calibrated.

Probe Replacement

A probe kit (80T-150-7001K, PN 431023) is available for replacing damaged or defective probes. The kit includes a probe and cable assembly and an installation and calibration instruction sheet.

List Of Replaceable Parts

A schematic of the 80T-150U is shown in Figure 4. A list of replaceable parts is shown in Figure 5. When ordering parts, provide the description, Fluke part number, and the quantity required.

Test Equipment Requirements

Instrument Type	Minimum Use Specifications	Recommended Model
Mercury Thermometer	0.1°C Resolution	Princo Model SAMA-CP45
Dewar Flask and Cap	1-Pint Capacity (for Ice Bath)	Thermos Bottle
Metal or Glass Container	1-Pint Capacity	Suitable for Boiling Water
Digital Voltmeter	100 mV Range with 10 μV Resolution 1000 mV Range with 100 μV	Fluke Model 8840A

For application or operation assistance or information on Fluke products, call:
800-44-FLUKE (800-443-5853) in U.S.A. and Canada, 31 40 267-8200 in Europe, 206-356-5500 from other countries

Fluke Corporation
P.O. Box 9090
Everett WA 98206-9090
USA

Fluke Europe B.V.
P.O. Box 1186
5602 B.D. Eindhoven
The Netherlands

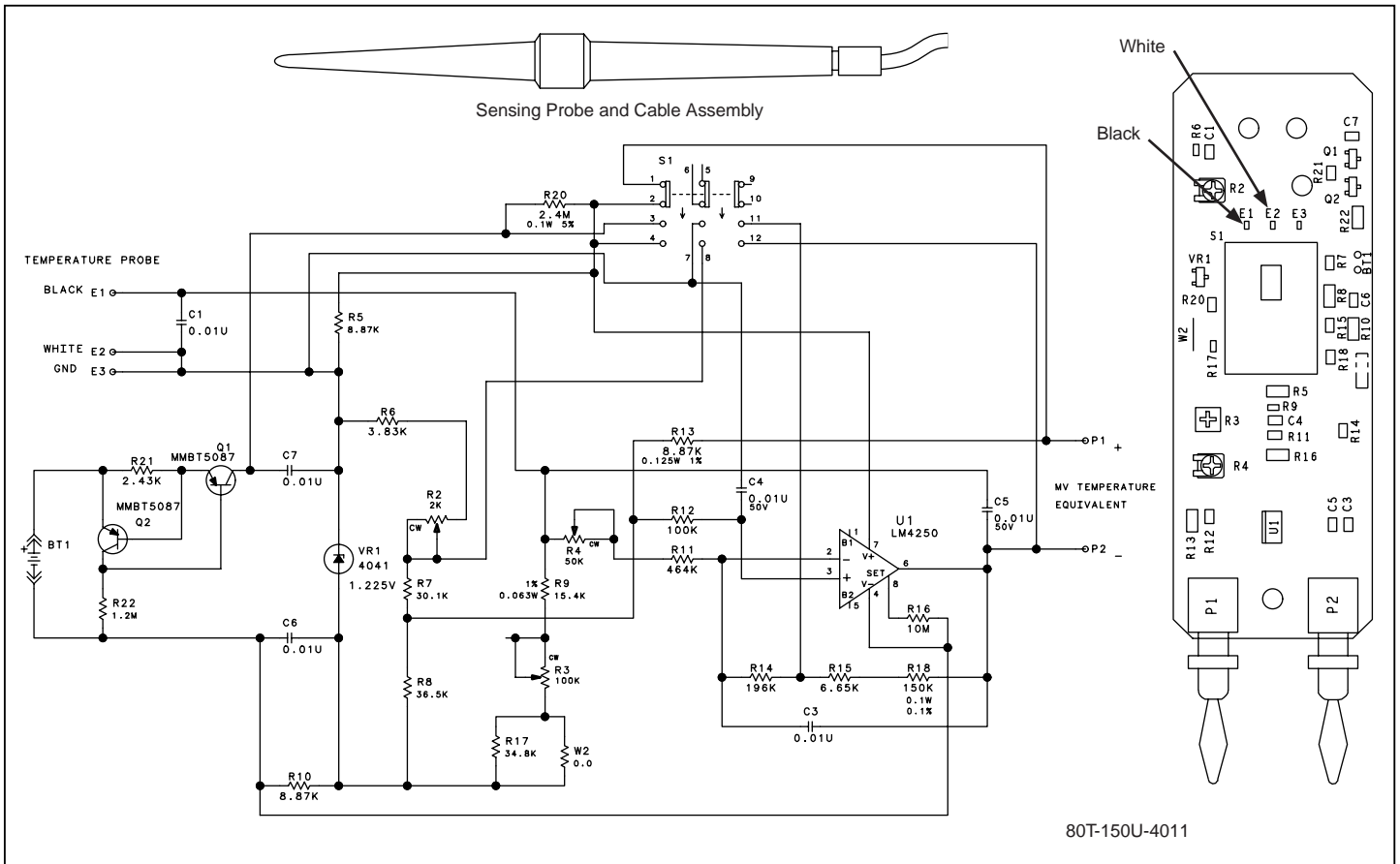

Figure 4. 80T-150U Temperature Probe Schematic

F4.eps

Replaceable Parts

Ref Des	PN	Description
BT1	738179	80TK-8011 ,CONNECTOR, BATTERY
C1 C3-C7	106146	CAPACITOR,SMR,CAP,CER,0.01UF,+10%,50V,X7R,0805
P1 P2	736033	80TK-8009,PLUG,BANANA
Q1 Q2	820910	PNP,MMBT5087,SMR,TRANSISTOR,SI,PNP,50V,225MW,SOT-23
R11	928903	RESISTOR,SMR,RES,CERM,464K,+1%,0.1W,100PPM,0805
R12	928866	RESISTOR,SMR,RES,CERM,100K,+1%,0.1W,100PPM,0805
R14	802733	RESISTOR,SMR,RES,MF,196K,+0.1%,0.1W,50PPM,0805
R15	802741	RESISTOR,SMR,RES,MF,6.65K,+0.1%,0.1W,50PPM,0805
R16	783274	RESISTOR,SMR,RES,CERM,10M,+5%,.125W,400PPM,1206
R17	642329	RESISTOR,SMR,RES,CERM,34.8K,+1%,.063W,100PPM,0603
R18	1541369	RESISTOR,METAL FILM,150K,+0.1%,0.1W,25PPM,0805,TAPE
R2	802758	RESISTOR,SMR,RES,VAR,CERM,2K,+20%,0.25W
R20	802642	RESISTOR,SMR,RES,CERM,2.4M,+5%,0.1W,400PPM,0805
R21	928754	RESISTOR,SMR,RES,CERM,2.43K,+1%,0.1W,100PPM,0805
R22	806240	RESISTOR,SMR,RES,CERM,1.2M,+5%,.125W,200PPM,1206
R3	912493	RESISTOR,SMR,RES,VAR,CERM,100K,+25%
R4	802766	RESISTOR,SMR,RES,VAR,CERM,50K,+20%,0.25W
R5 R10 R13	876016	RESISTOR,SMR,RES,CERM,8.87K,+1%,.125W,100PPM,1206
R6	642303	RESISTOR,SMR,RES,CERM,3.83K,+1%,.063W,100PPM,0603
R7	643954	RESISTOR,SMR,RES,MF,30.1K,+0.1%,0.1W,25PPM,0805
R8	929906	RESISTOR,SMR,RES,CERM,36.5K,+1%,.125W,100PPM,1206
R9	642220	RESISTOR,SMR,RES,CERM,15.4K,+1%,.063W,100PPM,0603
S1	772301	SWITCH,SWITCH,SLIDE,3P3T,WITH DETENT
U1	802774	IC,OP AMP,LM4250C,BIPOLAR
VR1	929489	BIPOLAR 4041,SMR,IC,V REF,SHUNT,1.2 V,2%,150 PPM,SOT23
W2	682575	RESISTOR,R05A,RES JUMPER,0.02,0.25W
	747501	SCREW,SCREW,PH,PO,STL,4-40,.250
	431023	SENSING PROBE AND CABLE ASSY
	172080	CABLE TIE
	615549	CASE,BOTTOM
	129882	SCREW,PHP,4-40X3/16
	769034	CASE, TOP
	735860	COVER, SWITCH
	428441	SHOCK ABSORBER

LIMITED WARRANTY & LIMITATION OF LIABILITY

Each Fluke product is warranted to be free from defects in material and workmanship under normal use and service. The warranty period is one year and begins on the date of shipment. Parts, product repairs and services are warranted for 90 days. This warranty extends only to the original buyer or end-user customer of a Fluke authorized reseller, and does not apply to fuses, disposable batteries or to any product which, in Fluke's opinion, has been misused, altered, neglected or damaged by accident or abnormal conditions of operation or handling. Fluke warrants that software will operate substantially in accordance with its functional specifications for 90 days and that it has been properly recorded on non-defective media. Fluke does not warrant that software will be error free or operate without interruption.

Fluke authorized resellers shall extend this warranty on new and unused products to end-user customers only but have no authority to extend a greater or different warranty on behalf of Fluke. Warranty support is available if product is purchased through a Fluke authorized sales outlet or Buyer has paid the applicable international price. Fluke reserves the right to invoice Buyer for importation costs of repair/replacement parts when product purchased in one country is submitted for repair in another country.

Fluke's warranty obligation is limited, at Fluke's option, to refund of the purchase price, free of charge repair, or replacement of a defective product which is returned to a Fluke authorized service center within the warranty period.

To obtain warranty service, contact your nearest Fluke authorized service center or send the product, with a description of the difficulty, postage and insurance prepaid (FOB Destination), to the nearest Fluke authorized service center. Fluke assumes no risk for damage in transit. Following warranty repair, the product will be returned to Buyer, transportation prepaid (FOB Destination). If Fluke determines that the failure was caused by misuse, alteration, accident or abnormal condition of operation or handling, Fluke will provide an estimate of repair costs and obtain authorization before commencing the work. Following repair, the product will be returned to the Buyer transportation prepaid and the Buyer will be billed for the repair and return transportation charges (FOB Shipping Point).

THIS WARRANTY IS BUYER'S SOLE AND EXCLUSIVE REMEDY AND IS IN LIEU OF ALL OTHER WARRANTIES, EXPRESS OR IMPLIED, INCLUDING BUT NOT LIMITED TO ANY IMPLIED WARRANTY OF MERCHANTABILITY OR FITNESS FOR A PARTICULAR PURPOSE. FLUKE SHALL NOT BE LIABLE FOR ANY SPECIAL, INDIRECT, INCIDENTAL OR CONSEQUENTIAL DAMAGES OR LOSSES, INCLUDING LOSS OF DATA, WHETHER ARISING FROM BREACH OF WARRANTY OR BASED ON CONTRACT, TORT, RELIANCE OR ANY OTHER THEORY.

Since some countries or states do not allow limitation of the term of an implied warranty, or exclusion or limitation of incidental or consequential damages, the limitations and exclusions of this warranty may not apply to every buyer. If any provision of this Warranty is held invalid or unenforceable by a court of competent jurisdiction, such holding will not affect the validity or enforceability of any other provision.