

Keysight Technologies 1180C Testmobile Scope Cart

Data Sheet

Add mobility to your instruments

The Keysight Technologies, Inc. 1180C testmobile scope cart provides convenient mobility of test equipment to make it readily available when needed and effectively extend the amount of lab bench space. Allows several operators to cost effectively share expensive equipment.

Features

- Ergonomic design, test equipment is operator-accessible whether seated or standing
- Heavy-duty casters make moving instruments easy
- Includes a steel buckle and nylon strap to secure instruments to the cart
- Attractive quartz gray color
- Tilt tray adjusts 30-plus degrees for viewing comfort

Specifications

- Material: Cold-rolled steel
- Weight: 25.9 kg (57 lbs)
- Color: Quartz gray
- Casters: 101 mm (4 in) diameter
- Tilt tray load capacity: 29.5 kg (65 lbs)
- Total load capacity: 59 kg (130 lbs)
- Tilt tray width: 457 mm (18 in)
- Tilt tray depth: 457 mm (18 in)

Installation

The 1180C is shipped virtually assembled except for its handle and casters. Place the handle in the rear top of the cart and secure with screws provided. Insert the casters in the corner holes on the underside of the cart. Attach the nylon strap on the slots of the instrument tray and thread through buckle.

Tools required for installation:

- Torx T25 screwdriver

What you get in the box

- Scope cart assembly with tray
- Torx T25 screwdriver
- Tubular handle
- Four casters
- All mounting hardware
- Nylon strap with steel buckle
- Installation instructions

What changed

- Color changed from parchment white to quartz gray

Related products

1181B Keysight testmobile system cart

Optional accessory

35183B Work surface

Replacement parts

1530-2054 Tie-down assembly strap

1492-0134 Caster, swivel with brake

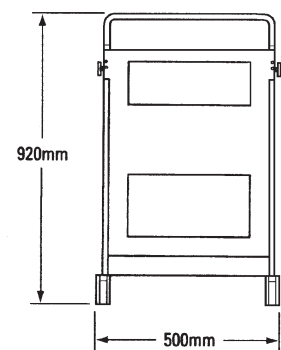
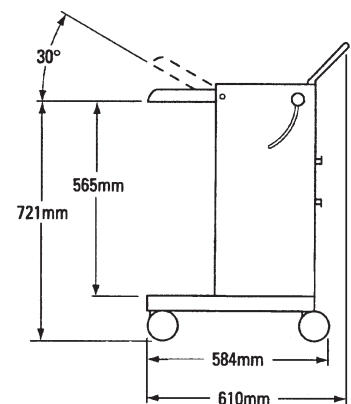

Warranty

Three year replacement

myKeysight

myKeysight

www.keysight.com/find/mykeysight

A personalized view into the information most relevant to you.

Three-Year Warranty

www.keysight.com/find/ThreeYearWarranty

Keysight's commitment to superior product quality and lower total cost of ownership. The only test and measurement company with three-year warranty standard on all instruments, worldwide.



www.keysight.com/find/assist

For more information on Keysight Technologies' products, applications or services, please contact your local Keysight office. The complete list is available at: www.keysight.com/find/contactus

Americas

Canada	(877) 894 4414
Brazil	55 11 3351 7010
Mexico	001 800 254 2440
United States	(800) 829 4444

Asia Pacific

Australia	1 800 629 485
China	800 810 0189
Hong Kong	800 938 693
India	0124 229 2010
Japan	0120 (421) 345
Korea	080 769 0800
Malaysia	1 800 888 848
Singapore	1 800 375 8100
Taiwan	0800 047 866
Other AP Countries	(65) 6375 8100

Europe & Middle East

Austria	0800 001122
Belgium	0800 58580
Finland	0800 523252
France	0805 980333
Germany	0800 6270999
Ireland	1800 832700
Israel	1 809 343051
Italy	800 599100
Luxembourg	+32 800 58580
Netherlands	0800 0233200
Russia	8800 5009286
Spain	800 000154
Sweden	0200 882255
Switzerland	0800 805353
	Opt. 1 (DE)
	Opt. 2 (FR)
	Opt. 3 (IT)
United Kingdom	0800 0260637

For other unlisted countries:
www.keysight.com/find/contactus
 (BP-02-06-15)