

Product	<b>cable outlet: 5.5 - 9 mm, Contacts: 8, Cable plug connector with X-coding, shieldable, CAT 6A, insulation displacement connection</b>
Area	<b>M12-D, M12-X Series 825 X-coding</b>
Article number	<b>99 3787 810 08</b>

**Illustration**

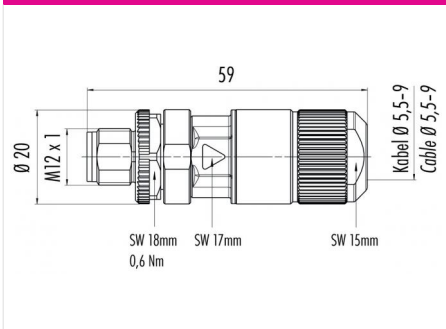

**Scale drawing**



**Contact Arrangement**

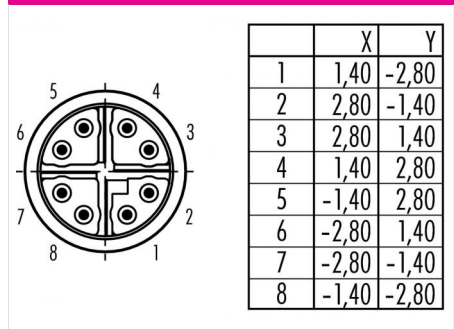

You can find the item description and assembly instruction on the next page.

**Technical data**

**Common values**

Connector Design	Cable plug connector
Connector locking system	screw
Termination	Screw terminal
Wire gauge (AWG)	27 - 22
Cable outlet	5.5 - 9 mm
Upper temperature	85 °C
Lower temperature	-40 °C

**Cable data**

material housing	-
Insulation single lead	-
Single lead structure	-
Conductor resistance	-
Bending radius cable fixed	-
Bending radius cable movable	-

**Electrical values**

Rated voltage	50 V AC / 60 V DC
Rated impulse voltage	800 V
Pollution degree	3
Overvoltage category	II
Material group	II
Rated current (40°C)	0.5 A
Volume resistivity	≤ 10 mΩ
Degree of protection	IP67
Mechanical operation	> 100 mating cycles

**Material**

Material of contact	CuZn (Brass)
Contact plating	Au (Gold)
Material of contact body	PA
Material of housing	Nickel-plated brass / nickel-plated zinc die casting

Product	<b> cable outlet: 5.5 - 9 mm, Contacts: 8, Cable plug connector with X-coding, shieldable, CAT 6A, insulation displacement connection</b>
Area	<b> M12-D, M12-X Series 825 X-coding</b>
Article number	<b> 99 3787 810 08</b>

Item description

- 1. Vormontierte Druckschraube.
- 2. Zusatzdichtung für Kabel-Ø 5,5-7,5 mm.
- 3. Adervorsortierung.
- 4. Steckereinsatz.

- 1. Premounted pressing screw.
- 2. Additional sealing for cable-Ø 5.5-7.5 mm.
- 3. Wire manager.
- 4. Male insert.

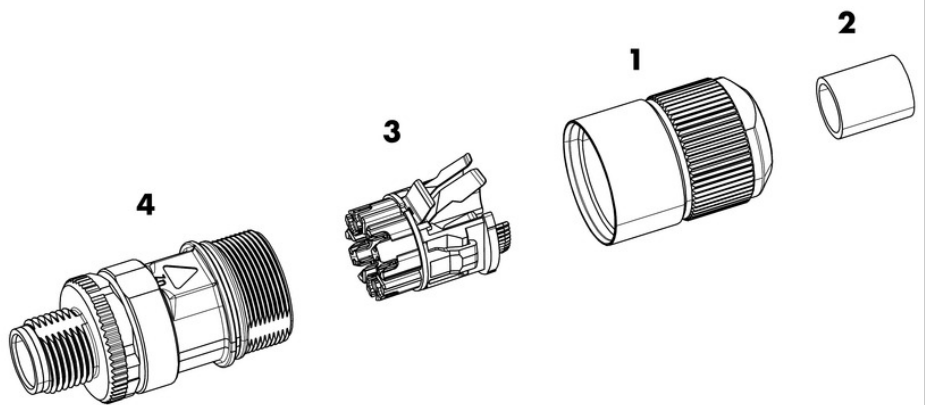

Installation instructions / Mounting cutout

