

Features

Regulated Converters

- 6-Side Shielding
- External ON/OFF control
- 1.6kVDC Isolation
- UL/CSA/EN-60950-1 (Pending)
- 2:1 Input Voltage Range
- Continuous Short Circuit Protection
- Efficiency up to 90.5%
- Fixed Switching Frequency

REC20

20 Watt
2" x 1"
Single and Dual Output



Description

The REC20-xxxxS_D-series offer single and dual regulated outputs in a 2"x1" package with 1.6kVDC isolation and are suitable for higher power industrial applications. Remote on/off control is standard. The higher current outputs have raised output voltages to compensate for track losses as standard. The converter is fully certified to UL/EN/IEC safety standards.

Selection Guide

Part Number	Input Voltage Range (VDC)	Output Voltage (VDC)	Output Current (mA)	Efficiency typ. (%)	max. Capacitive Load (µF)
REC20-123.4S	9-18	3.4	5000	85	10000
REC20-125.1S	9-18	5.1	4000	89	6800
REC20-1212S	9-18	12	1670	88.5	1800
REC20-1215S	9-18	15	1340	88.5	1000
REC20-1212D	9-18	±12	±835	89	±800
REC20-1215D	9-18	±15	±670	89	±500
REC20-243.4S	18-36	3.4	5000	86	10000
REC20-245.1S	18-36	5.1	4000	90	6800
REC20-2412S	18-36	12	1670	89	1800
REC20-2415S	18-36	15	1340	90	1000
REC20-2412D	18-36	±12	±835	89.5	±800
REC20-2415D	18-36	±15	±670	89.5	±500
REC20-483.4S	36-75	3.4	5000	86.5	10000
REC20-485.1S	36-75	5.1	4000	89	6800
REC20-4812S	36-75	12	1670	89	1800
REC20-4815S	36-75	15	1340	90	1000
REC20-4812D	36-75	±12	±835	89.5	±800
REC20-2415D	36-75	±15	±670	90.5	±500



IEC/EN60950-1 (Pending)
UL60950 (Pending)
CSA C22.2 NO. 60950 (Pending)
EN55022 Certified

Model Numbering



Notes:

Note2:	12 =	9-18Vin
	24 =	18-36Vin
	48 =	36-75Vin

Examples:

- e.g. REC30-1212S, Single Output, 9-18Vin (2:1) and 12Vout
- e.g. REC30-2412D, Dual Output, 18-36Vin (2:1) and ±12Vout

Refer to Applications Notes

Specifications (measured at $T_a=25^\circ\text{C}$, nominal input voltage, full load and after warm up unless otherwise specified)

BASIC CHARACTERISTICS					
Parameter	Condition		Min.	Typ.	Max.
Input Voltage Range	12V		9VDC		18VDC
	24V		18VDC		36VDC
	48V		36VDC		75VDC
Start/up Time				10mS	
Under Voltage Lockout	12V	DC-DC ON		8.6VDC	
		DC-DC OFF		7.8VDC	
	24V	DC-DC ON		17.6VDC	
		DC-DC OFF		16.8VDC	
48V	DC-DC ON		34.6VDC		
	DC-DC OFF		33.8VDC		
Remot ON/OFF	DC-DC ON				Open or $3V < V_r < 12V$
	DC-DC OFF				Short or $0V < V_r < 1.2V$
Operating Frequency				350kHz	
Minimum Load				0%	
Output Ripple and Noise ⁽⁴⁾				100mVp-p	

Notes:

Note4: Ripple and Noise is measured with a 20MHz bandwidth and a 0.1µF ceramic capacitor.

Efficiency vs. Load

REC20-485.1S

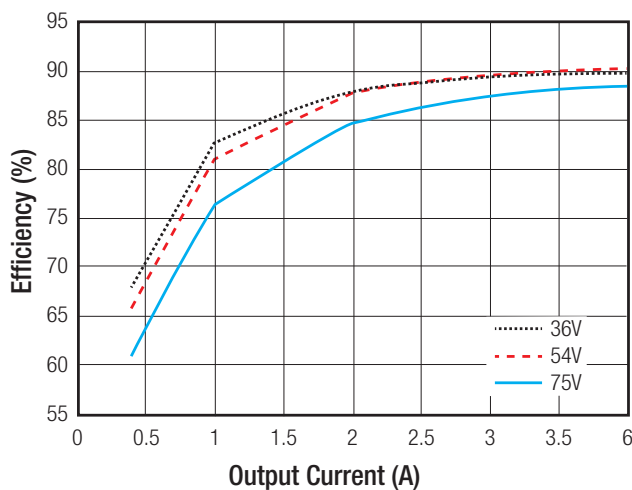

REC20-2415S

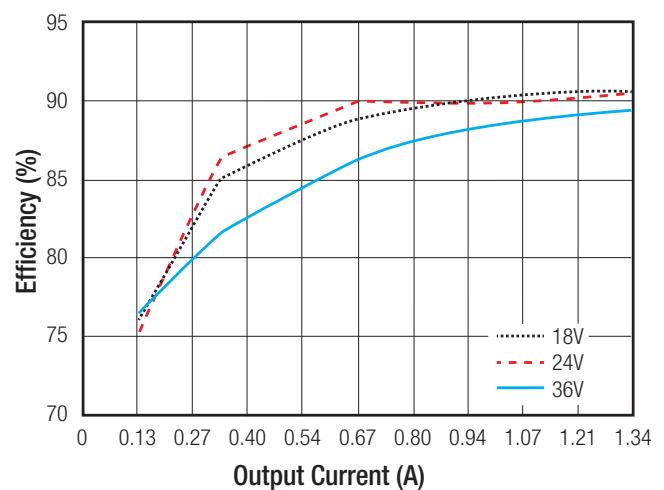

REGULATIONS				
Parameter	Condition	Type	Values	
Output Voltage Accuracy			±1% typ. / ±1.5% max.	
Voltage Adjustability			±10% typ.	
Line Voltage Regulation	low line to high line, full load		±0.2% max.	
Load Voltage Regulation	10% to 100% load		±0.5% max.	
Cross Regulation	25% to 100% load	dual output	±5% max.	
Transient Response Recovery Time	25% load step change		250µS typ.	

continued on next page

Specifications (measured at $T_a=25^\circ\text{C}$, nominal input voltage, full load and after warm up unless otherwise specified)

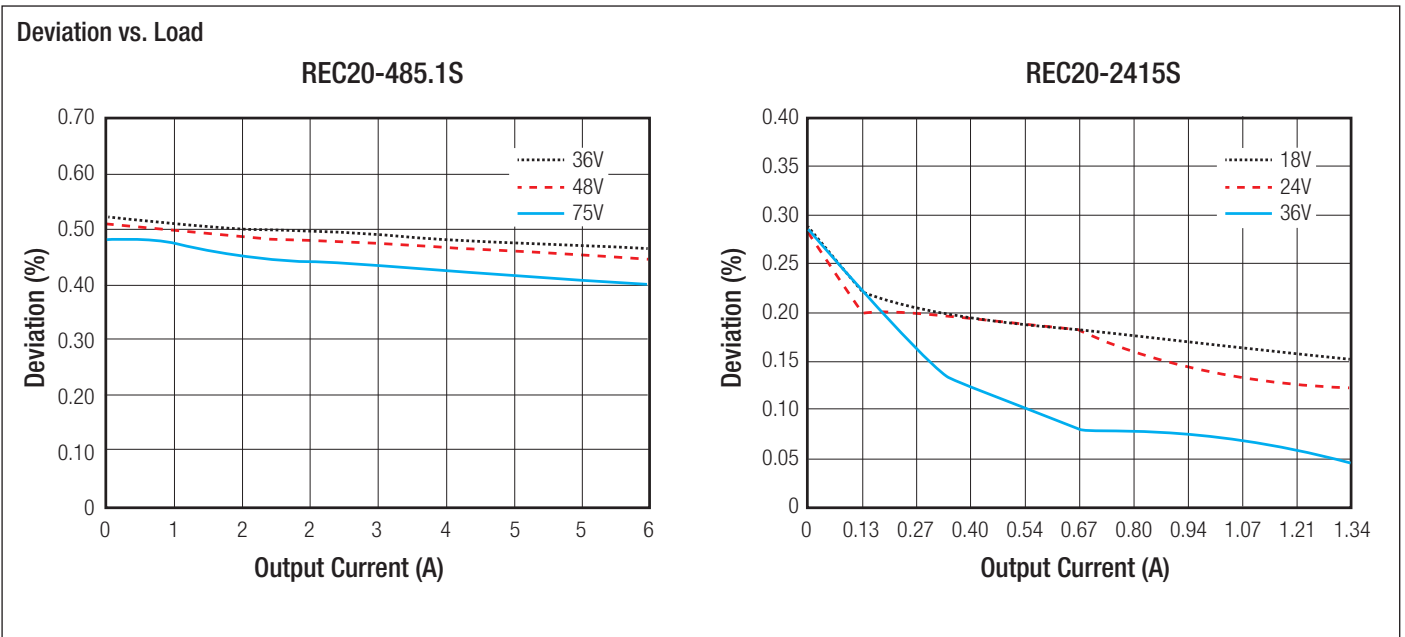

PROTECTIONS		
Parameter	Condition	Value
Short Circuit Protection (SCP)		continuous, automatic recovery
Over Voltage Protection (OVP)	Zener Diode Clamp	3.4Vout
		5.1Vout
		12Vout
		15Vout
Over Load Protection (OLP)		140% typ.
Isolation Voltage	I/P to O/P	1.6kVDC / 1 minute
Isolation Capacitance		1000pF typ.
Isolation Resistance		1GΩ min.

ENVIRONMENTAL		
Parameter	Condition	Value
Operating Temperature Range	with derating	-40°C to +100°C
Maximum Case Temperature		+100°C
Temperatur Coefficient		0.05%/°C typ.
Operating Humidity	non-condensing	5% - 95% RH max.
Vibration		MIL-STD-202G
MTBF	according to MIL-HDBK-217F, 25°C, referring to REC20-125.1S	607 x 10 ³ hours

continued on next page

Specifications (measured at $T_a = 25^\circ\text{C}$, nominal input voltage, full load and after warm up unless otherwise specified)

Derating Graph

@ nominal input voltage, full load and natural convection (20LFM)

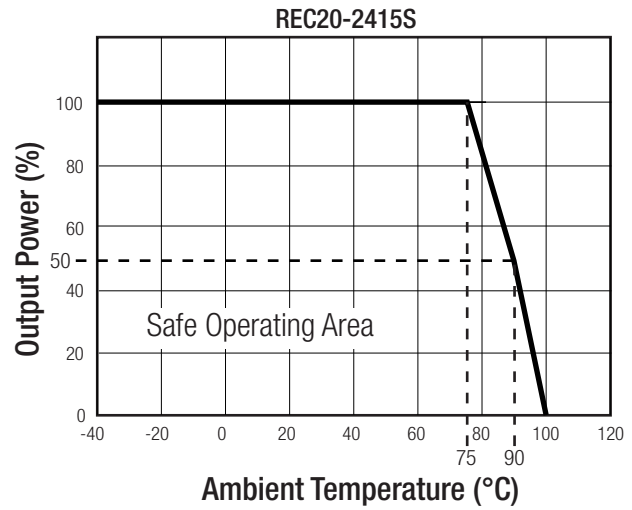
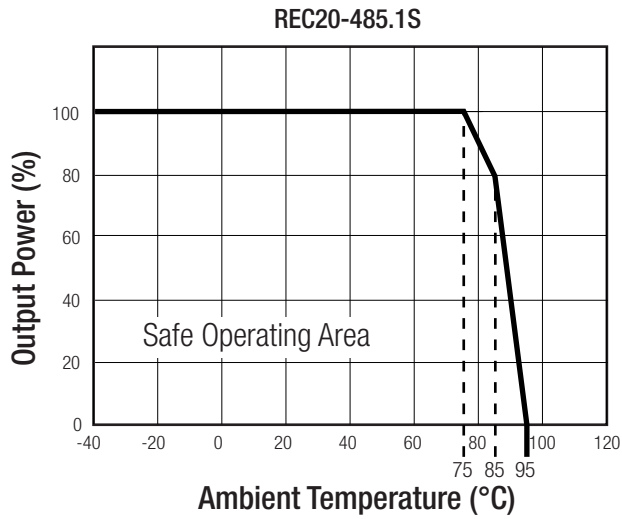

Notes:

Note5: For more details, please contact our technical support service at TechsupportAT@recom-power.com

SAFETY AND CERTIFICATIONS

Certificate Type	Report / File Number	Standard
CB General Safety	E224736	IEC60950-1, 2nd Edition, 2013
UL General Safety		UL60950-1, 2nd Edition, 2014
EN General Safety		EN60950-1, 2nd Edition, 2013
CAN/CSA General Safety		C22.2 No. 60950-1-07, 2014

EMC Compliance	Condition	Standard / Criterion
EMI	with external filter (see filter suggestions)	EN55022, Class A,B
ESD	Air: $\pm 8\text{kV}$; Contact: 4kV	EN61000-4-2, Criteria B
Radiated Immunity	10V/m	EN61000-4-3, Criteria A
Fast Transient	$\pm 1\text{kV}$	EN61000-4-4, Criteria B
Surge ⁽⁷⁾	$\pm 1\text{kV}$	EN61000-4-5, Criteria A
Conducted Immunity	10Vr.m.s	EN61000-4-6, Criteria A
Power Magnetic Field	$50\text{Hz } 1\text{A/m (r.m.s)}$	EN61000-4-8, Criteria A

Notes:

Note7: An external MOV is required if the module has to meet EN61000-4-5. The MOV suggest: NichTek SVI32-380

EMC Filtering - Suggestions for Class A

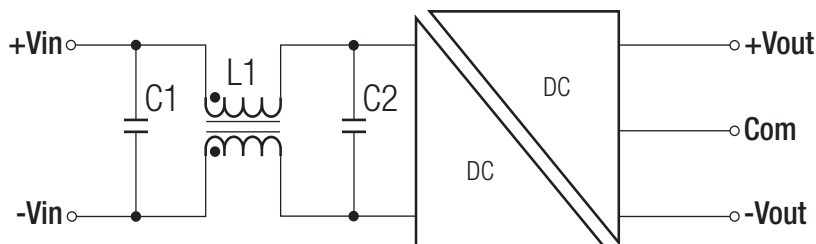

MODEL	C1	C2	L1
REC20-12xxS(D)	4.7 $\mu\text{F}/50\text{V}$	NA	0.45mH
REC20-24xxS(D)	4.7 $\mu\text{F}/50\text{V}$	NA	0.45mH
REC20-48xxS(D)	2.2 $\mu\text{F}/100\text{V}$	2.2 $\mu\text{F}/100\text{V}$	0.45mH

continued on next page

Specifications (measured at $T_a = 25^\circ\text{C}$, nominal input voltage, full load and after warm up unless otherwise specified)

EMC Filtering - Suggestions for Class B

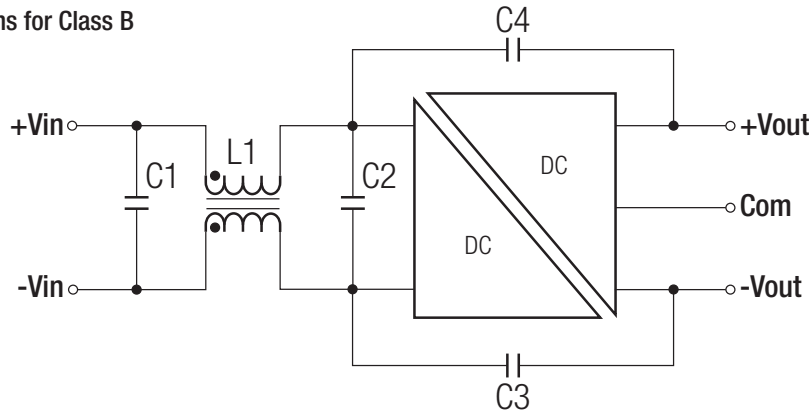

MODEL	C1	C2	L1	C3	C4
REC20-12xxS(D)	10 μF /50V	10 μF /50V	0.45mH	1nF/2kV	1nF/2kV
REC20-24xxS(D)	4.7 μF /50V	NA	0.45mH	1nF/2kV	1nF/2kV
REC20-48xxS(D)	2.2 μF /100V	4.7 μF /100V	0.67mH	3.3nF/2kV	3.3nF/2kV

DIMENSION and PHYSICAL CHARACTERISTICS

Parameter	Type	Value
Material	Case Base Potting	Nickel plated copper non conductive black plastic (UL94V-0) Epoxy
Package Dimension (LxWxH)		50.8 x 25.4 x 10.2mm
Package Weight		27g

Dimension Drawing (mm)

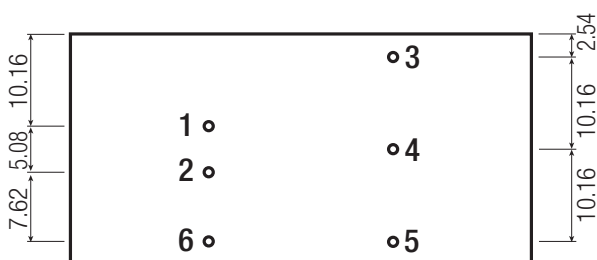
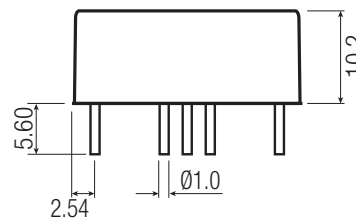
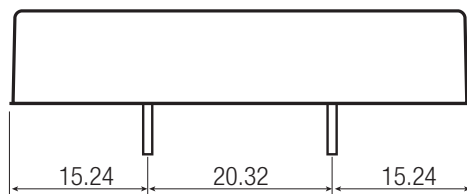
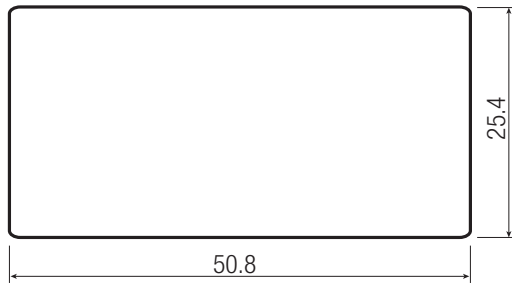
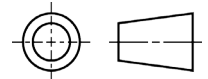

Pin Connections

Pin #	Single	Dual
1	+Vin	+Vin
2	-Vin	-Vin
3	+Vout	+Vout
4	Trim	Com
5	-Vout	-Vout
6	Remote On/Off	

Tolerance: xx.x= $\pm 0.5\text{mm}$
 xx.xx= $\pm 0.35\text{mm}$
 Pin: $\pm 0.05\text{mm}$

Specifications (measured at $T_a = 25^\circ\text{C}$, nominal input voltage, full load and after warm up unless otherwise specified)

INSTALLATION and APPLICATION

External Output Voltage Trimming

Trim up

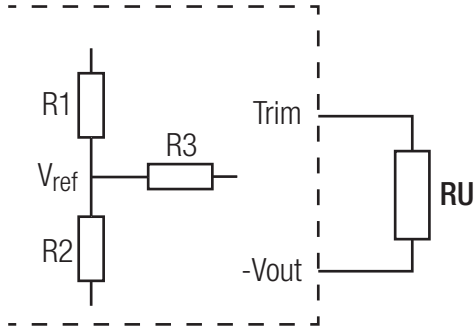

$$RU = \frac{aR2}{R2-a} - R3 \quad a = \frac{V_{ref}}{V_0 - V_{ref}} \times R1$$

Trim down

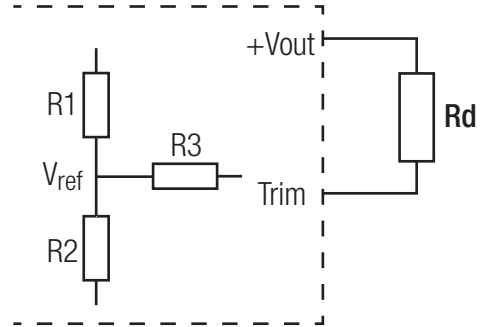

$$Rd = \frac{bR1}{R1-b} - R3 \quad b = \frac{V_{ref}}{V_0 - V_{ref}} \times R2$$

Notes:

- Note8: RU and Rd is mean trim resistor, please check the formula.
- Note9: a & b: user define parameter, no actual meanings.
- Note10: V₀ is mean trim up/down voltage.
- Note11: Value for R1, R2, R3 and Vref refer to table.

Output Voltage	3.4V	5.1V	12V	15V
R1	2.1K	2.21K	8.87K	6.04K
R2	1.2K	2.1K	2.4K	1.2K
R3	4.7K	7.32K	15K	9.76K
Vref	1.24V	2.5V	2.5V	2.5V

PACKAGING INFORMATION

Packaging Dimension (LxWxH)	Tube	54.5 x 20.8 x 520.0mm
Packaging Quantity		18pcs
Storage Temperature Range		-55°C to +125°C

Tube Dimension Drawing (mm)

