

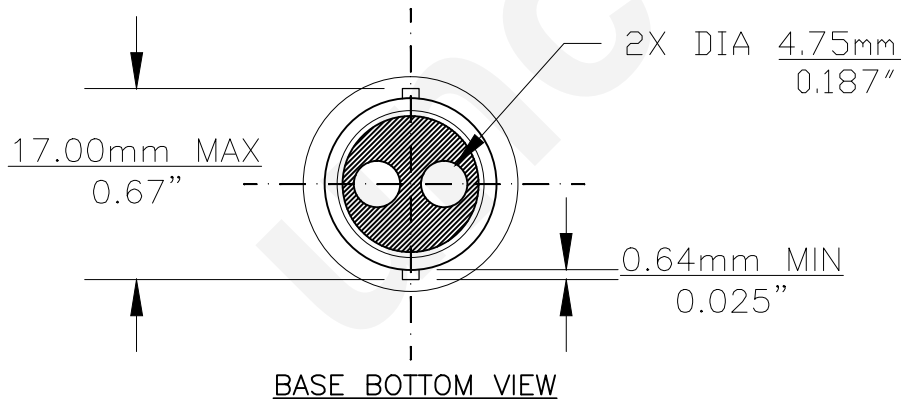

PART NO.	BASE TYPE	DESIGN VOLTS	DESIGN AMPS	MSCD	FILAMENT TYPE	AVERAGE LIFE HOURS	REVISIONS			
							REV #	DESCRIPTION	DATE	APPROVED
624	D.C. BAYONET (BA15d)	28.0V	0.37±20%	6 ±20%	2C-6	1,000	1	REDRAWN	06/16/2005	D.C.
							2	REDRAWN FOR ADDITIONAL VIEW	11/13/2014	R.M.

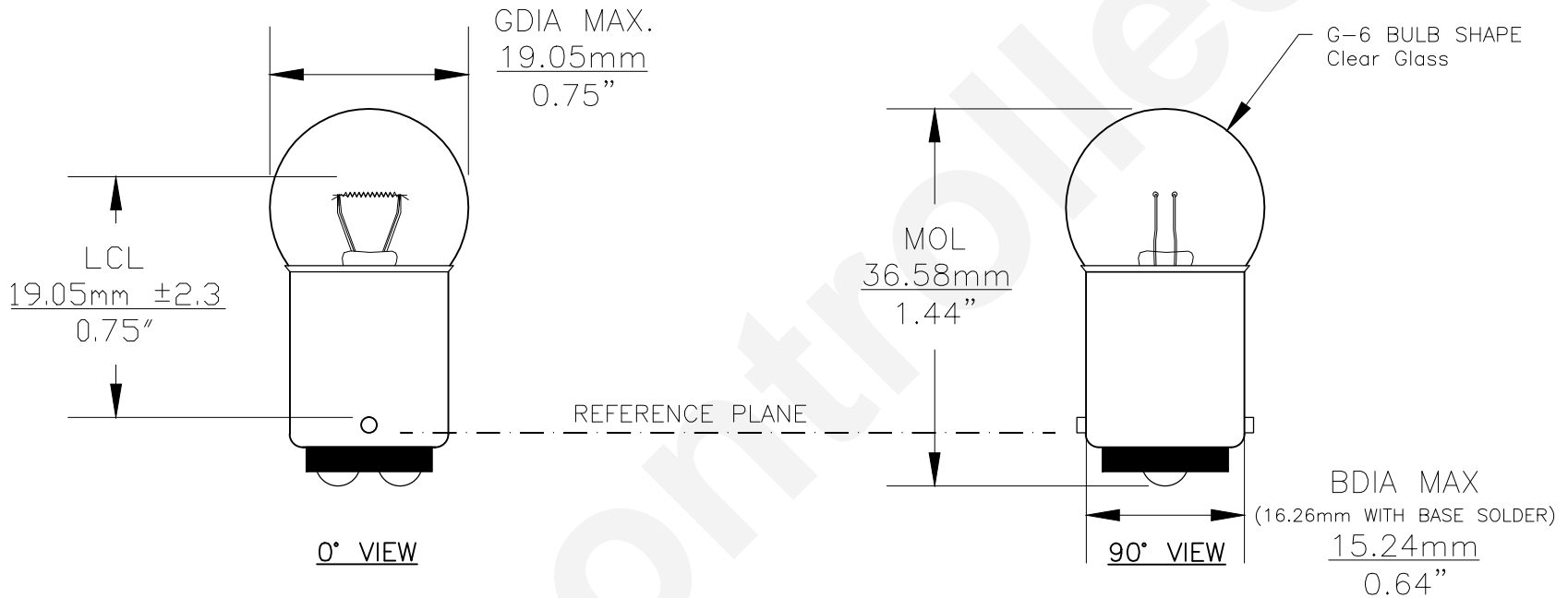

Note: Made according to SAE specifications

UNLESS OTHERWISE SPECIFIED: DIMENSIONS ARE IN INCHES TOLERANCES		CEC INDUSTRIES LTD			
DECIMALS .XX ± .05		599 BOND STREET		LINCOLNSHIRE, IL 60069	
ANGULAR .XXX ± .010		TITLE LIGHT BULB NO. 624			
FRACTIONAL ±1/64		DATE 02/01/2001	SIZE A	DWG NO. 624	REV 1
DRAWN ELIZABETH SONANES	CHECKED	SCALE	PLOT SCALE	SHEET 1 OF 1	
DESIGN	MATERIAL	FILE 624.pdf	DRAWING NOT TO SCALE		