

# PS82 – Economical Miniature Vacuum Switches

► 5" to 28" Hg (169 to 948 mbar)

These miniature vacuum switches, based on our proven PS71 series, are designed for demanding applications where space and/or price are strong concerns.

## Specifications

<b>Switch</b>	SPST; SPDT
<b>Repeatability</b>	See Table 1
<b>Wetted Parts</b>	
<b>Diaphragm Material</b>	Nitrile standard (optional EPDM, Viton® and Neoprene)
<b>Fitting</b>	Brass (optional 316 Stainless Steel)
<b>Spring</b>	316 Stainless Steel
<b>Electrical Termination</b>	DIN 43650A IP65; Male Conduit with Flying Leads IP65; Flying Leads IP00; IP option IP66
<b>Proof Pressure</b>	0 psia to 350 psig (-1 bar to 24 bar)
<b>Burst Pressure</b>	700 psi (48 bar)
<b>Approvals</b>	CE
<b>Weight, Approximate</b>	Brass: 0.4 lbs. (0.18 kg)

## Recommended Operating Temperature Limits

Diaphragm Material	Options Selected		
	No option, -10A, -SP or -RD	-RD or -RD and -G	-SP or -10A
<b>Nitrile</b>	15°F to 185°F (-9°C to +85°C)	15°F to 250°F (-9°C to +121°C)	15°F to 212°F (-9°C to +100°C)
<b>Viton®</b>	0°F to 185°F (-18°C to +85°C)	0°F to 250°F (-18°C to +121°C)	0°F to 212°F (-18°C to +100°C)
<b>EPDM</b>	-10°F to +185°F (-23°C to +85°C)	-10°F to +250°F (-23°C to +121°C)	-10°F to +212°F (-23°C to +100°C)
<b>Neoprene</b>	-10°F to +185°F (-23°C to +85°C)	-10°F to +250°F (-23°C to +121°C)	-10°F to +212°F (-23°C to +100°C)

Note: Switches may function below the cold temperature limit but the set points and deadband will increase. Consult factory for details.

## Electrical Switch Ratings

Options Selected	AC	DC
No option or -RD	5 amps @ 125/250 Volts	5 amps resistive, 3 amps inductive @ 28 Volts
-G only or -RD with -G	1 amp @ 125 Volts	1 amp resistive, 0.5 amp inductive @ 28 Volts
-10A only or -SP without -G	10.1 amps @ 125/250 Volts	—
-SP with -G	2 amps @ 125/250 Volts	—



## Dimensions

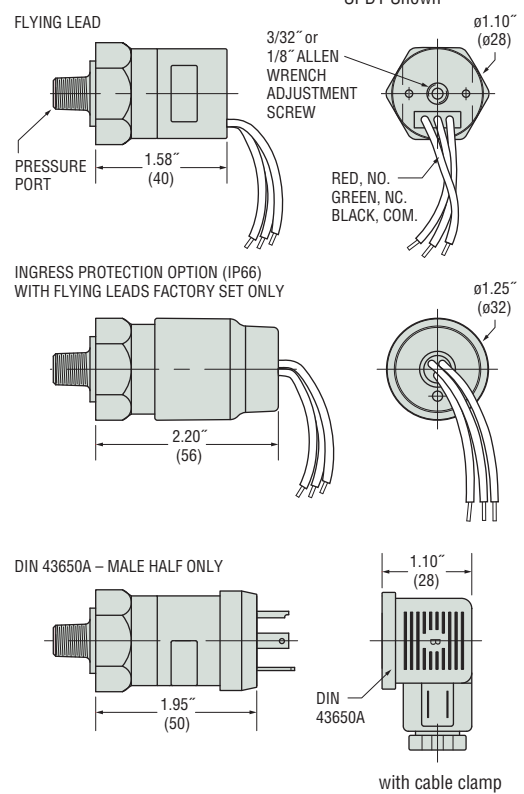

PRESSURE SWITCHES

How To Order

Use the **Bold** characters from the chart below to construct a product code. Please reference Notes.

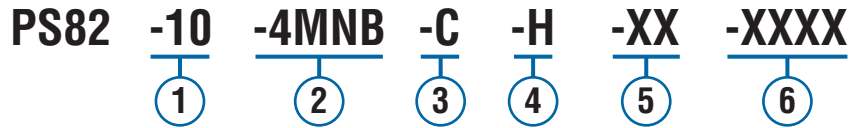

1 Pressure Range Code

Insert Pressure Range Code from Table 1, below.

2 Pressure Fitting<sup>1</sup>

Brass

- 2MNB = 1/8" NPTM
- 4MNB = 1/4" NPTM
- 2MGB = 1/8" BSPM (G type)
- 4MGB = 1/4" BSPM (G type)
- 4MSB = 7/16"-20 SAE Male
- 6MSB = 9/16"-18 SAE Male

316 Stainless Steel

- 2MNS = 1/8" NPTM
- 4MNS = 1/4" NPTM
- 4MGS = 1/4" BSPM (G type)

3 Circuit

- A = SPST/N.O.
- B = SPST/N.C.
- C = SPDT

4 Electrical Termination

- FLXX = Flying Leads<sup>2</sup>
- FLSXX = Flying Leads w/PVC Shrink Tubing<sup>2</sup>
- ELXX = 1/2" NPT Male Conduit w/Flying Leads<sup>3</sup>
- CABXX = 18 AWG PVC Cable<sup>4</sup>
  - H = DIN 43650A Male Half Only<sup>5</sup>
  - HR = Right Angle DIN 43650A Male Half Only<sup>5</sup>
  - HC = DIN 43650A 9mm Cable Clamp<sup>5</sup>
  - HCR = Right Angle DIN 43650A 9mm Cable Clamp<sup>5</sup>
  - HN = DIN 43650A with 1/2" Female NPT Conduit<sup>5</sup>
  - HNR = Right Angle DIN 43650A with 1/2" Female NPT Conduit<sup>5</sup>
  - HM = Micro (9.4mm Spacing) DIN Style Male Half Only<sup>5</sup>
  - SP = Spade Terminals<sup>6</sup>

5 Options

- 10A = 10A @ 125/250 VAC Max. Rating<sup>7</sup>
- V = Viton<sup>®</sup> Diaphragm
- N = Neoprene Diaphragm
- E = EPDM Diaphragm
- G = Gold Contacts  
(for loads less than 12 mA @ 12 VDC)
- RD = Reduced Differential  
(25% reduction typical)
- IP = Ingress Protection<sup>8</sup>
- OXY = Oxygen Cleaned
- WF = Weather Pack Connector, Female
- WM = Weather Pack Connector, Male
- DE = Deutsch Connector, Male, DT04 Series

6 Fixed Set Point (optional)

- A. Specify set point **-FS**  
(in Inches Hg or mBAR, see example)<sup>9</sup>
- B. Set Point Actuation  
**R** on Rising Vacuum  
**F** on Falling Vacuum  
Example: **-FS300MBARF** for 300 mBAR Falling  
or **-FS10INHGR** for 10" Hg Rising

Notes:

1. Other fittings available. Consult factory.
2. 18" is standard. Specify lead length in inches (max. 48"). e.g. **-FL18** or **-FLS30**.
3. 18" is standard. Specify lead length in inches (max. 48"). e.g. **-EL18** or **-EL30**.
4. 36" is minimum. Specify cable length in inches. e.g. **-CAB36** or **-CAB120**.
5. DIN connectors require **-C** SPDT circuit.
6. Requires **-10A**, **-G** options (50% increase in deadband typical).
7. Options **-10A**, **-G** or **-RD** cannot be combined.
8. Ingress Protection is available only with **-FL**, **-FLS**, **-ELS** or **-CAB** Electrical Termination choices. Ingress Protection requires Fixed Set Point **-FS**.
9. Set Point must be within Pressure Range selected in Step 1.

Table 1 — Vacuum Range Codes

The deadband values tabulated are for the standard microswitch. With either the -SP or -10A option, the deadband values are typically 50% greater than those listed. With the -RD option, the values will be typically 25% less than those listed. In certain applications deadband can be tailored and controlled to customer specifications. Consult factory for details.

Vacuum Range Code	Vacuum Range	Repeatability	Average Deadband*
<b>10</b>	5-15" Hg (169-508 mbar)	±0.71" Hg (24 mbar) +2% of setting	3.05" Hg (103 mbar) +7% of setting
<b>20</b>	12-28" Hg (406-948mbar)	±1.63" Hg (55 mbar) +2% of setting	6.1" Hg (207 mbar) +8% of setting

\* -IP and -EL options are approximate gauge switches. Altitude and temperature changes will result in set point shifts.