

Male Style C Press-Fit



Series 8458 – 3 rows (3 x 32)



Contact Design and Termination Length	Number of Contacts	Loading Description	Part Number Performance classes according to DIN 41612	
			II	I
for ≥ 2.4 mm PCB's 0.6 x 0.6 mm Post Profile 5.3 mm (Y) Right Angled	96	a + b + c fully loaded	10 8458 096 001 025	10 8458 096 001 049
	64	a + c fully loaded	10 8458 096 001 026	10 8458 096 001 050
	32	a + c even loading	10 8458 096 001 033	10 8458 096 001 057
	32	a loading only	10 8458 096 001 027	10 8458 096 001 051
	94 + 2	fully loaded + ground	10 8458 096 101 025	10 8458 096 101 049
for 1.6 mm PCB's 0.6 x 0.6 mm Post Profile 3.0 mm (Y) Right Angled	96	a + b + c fully loaded	10 8458 096 031 025	10 8458 096 031 049
	64	a + c fully loaded	10 8458 096 031 026	10 8458 096 031 050
	32	a + c even loading	10 8458 096 031 033	10 8458 096 031 057
	32	a loading only	10 8458 096 031 027	10 8458 096 031 051
	94 + 2	fully loaded + ground	10 8458 096 131 025	10 8458 096 131 049

NB: Alternative Prefix Variations Available: 12, please refer to Page 10.
 Additional Plating & Loading Variations: Please contact your local AVX sales office or distributor.

LOADING DESCRIPTION

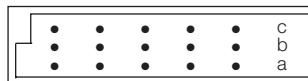

96 contacts, rows a + b + c fully loaded

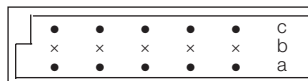

64 contacts, rows a + c fully loaded

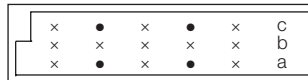

32 contacts, rows a + c even loading

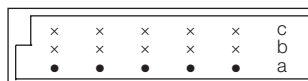

32 contacts, row a loading only

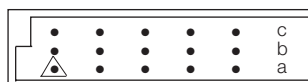

94 + 2 contacts, fully loaded with ground in A1 + A32

△ denotes ground pin

DIMENSIONS

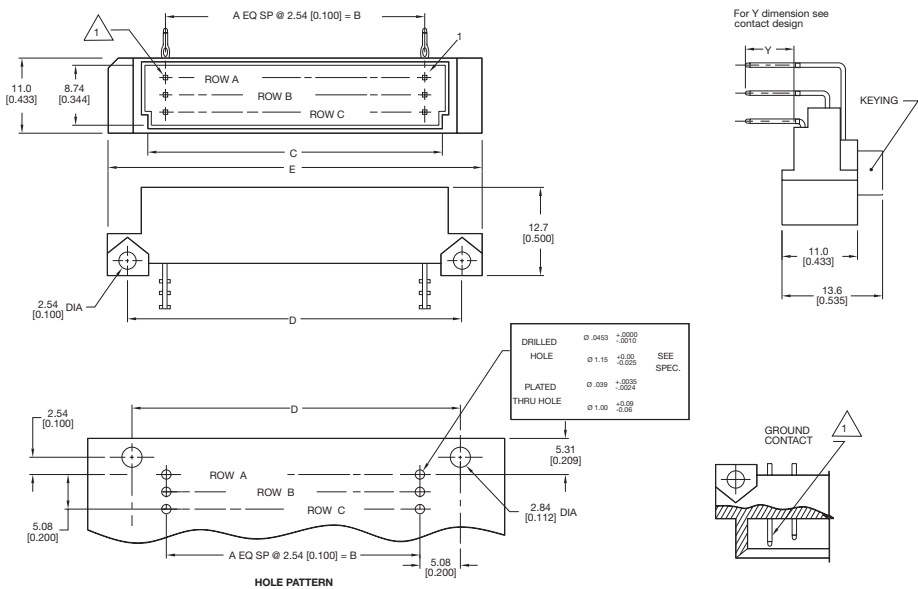

Assembly Tool: 06 8458 9271 00 000 (see page 67)

Unit: millimeters (inches)

No. Contact Positions	Contact Rows	A	B	C	D	E
96	3 (3 x 32)	31	78.74 (3.100)	85.29 (3.358)	88.90 (3.500)	93.90 (3.697)

Part Numbering Format

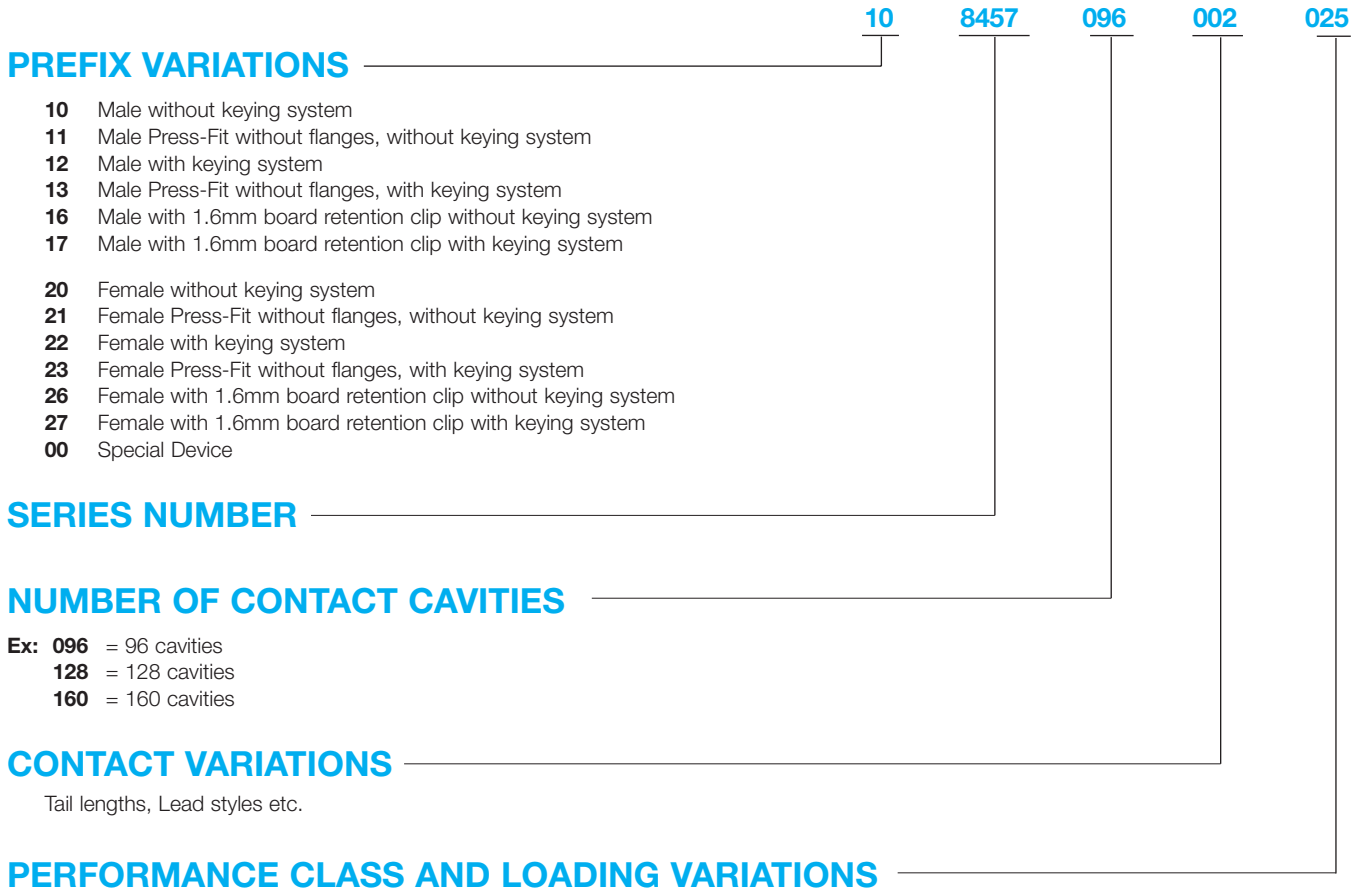

Class	M55302 Class I	DIN 41612 Class II	DIN 41612 Class III
Cycle Life	500+ Mating Cycles	400 Mating Cycles	50 Mating Cycles

QUALIFIED MILITARY PART NUMBERS

Military Designation	
M55302/131-01	M55302/134-02
M55302/131-02	M55302/134-04
M55302/132-01	M55302/134-05
M55302/132-02	M55302/134-07
M55302/132-03	M55302/134-08
M55302/132-04	M55302/157-01
M55302/132-05	M55302/157-02
M55302/132-06	M55302/157-03
M55302/133-01	M55302/157-04
M55302/133-02	M55302/158-01
M55302/133-03	M55302/158-02
M55302/134-01	

Technical Specifications



inches (mm)

SERIES 8254/8459 8457/8458 8477/8478 8483/8484	Basic Grid	0.100 (2.54) x 0.100 (2.54) - 0.100 (2.54) x 0.200 (5.08)
	Insertion Force	3.0 oz./ .83 N average per contact pair (20.23/90N max. for 96 contacts)
	Withdrawal Force	Average per contact pair (.54 oz./0.15N min. per contact)
	Contact Positions	2 x 16, 2 x 32, 3 x 10, 3 x 16, 3 x 32, 3 x 50, 4 x 32, 4 x 50, 5 x 32
	Contact Resistance	20 milliohms max.
	Current Rating* (see note)	3 amperes @ 20°C max. on connectors up to 96 contacts 1 ampere max. on connectors from 100 to 201 contacts
	Insulation Resistance	5,000 megohms min. at 500 VDC
	Dielectric Withstanding	1,000 VAC rms at sea level
	Operating Temperature	-65°C to +125°C
	Insulator Material	Thermoplastic polyester (GF), 94 V-O, UL rated
	Socket Contact Material	Phosphor bronze
	Pin Contact Material	Copper tin
	Wrap Post Dimension	0.024 x 0.024 (0.6 mm x 0.6 mm)
	Push-Out Force of Post in Insulator	3 lbs.
	Contact Plating	DIN performance classes
	SERIES 8447	Basic Grid
Insertion Force		4.0 oz./1.11 N average per contact pair (9.0 lbs./40N max. for 32 contacts)
Withdrawal Force		Average per contact pair (.54 oz./0.15N min. per contact)
Contact Positions		2 x 16, 3 x 16
Contact Resistance		15 milliohms max.
Current Rating* (see note)		5.5 amperes @ 20°C max.
Insulation Resistance		5,000 megohms min. at 500 VDC
Dielectric Withstanding		1,550 VAC rms at sea level
Operating Temperature		-65°C to +125°C
Insulator Material		Thermoplastic (GI), 94 V-O, UL Rated
Pin Contact Material		Copper alloy
Wrap Post Dimension		1.0 mm x 1.0 mm
Contact Plating		DIN performance classes
SERIES 8557/8577	Basic Grid	0.100 (2.54) x 0.100 (2.54) - 0.100 (2.54) x 0.200 (5.08)
	Insertion Force	3.0 oz./ .83 N average per contact pair (20.23/90N max. for 96 contacts)
	Withdrawal Force	Average per contact pair (.54 oz./0.15N min. per contact)
	Contact Positions	3 x 16, 3 x 32, 4 x 32, (inverted receptacle)
	Contact Resistance	20 milliohms max.
	Current Rating* (see note)	3 amperes @ 20°C max. on connectors up to 96 contacts
	Insulation Resistance	5,000 megohms min. at 500 VDC
	Dielectric Withstanding	1,000 VAC rms at sea level
	Operating Temperature	-65°C to +125°C
	Insulator Material	Surface mount compatible polymers, 94 V-O, UL Rated
	Socket Contact Material	Phosphor bronze
	Pin Contact Material	Copper alloy
	Wrap Post Dimension	0.024 x 0.024 (0.6 mm x 0.6 mm)
	Push-Out Force of Post in Insulator	3 lbs.
	Contact Plating	DIN performance classes
	Solder Temperature	max. 250°C

*Current Rating: UL approval allows that DIN connectors up to 96 contacts be rated at 3 amperes. Over 96 pins must be derated to 1.0 ampere maximum VDE, CSA, and other European standards rate all DIN and DIN type connectors at 1 ampere maximum when they are on an 0.100 (2.54) x 0.100 (2.54) grid. (UL file # E27610 Vol. #1 Section #6)

Technical Specifications



inches (mm)

SERIES 8449/8450 8456/8454 8487	Basic Grid	0.200 (5.08) x 0.200 (5.08)
	Insertion Force	4.0 oz./1.11 N average per contact pair (9.0 lbs./40N max. for 32 contacts)
	Withdrawal Force	Average per contact pair (.54 oz./0.15N min. per contact)
	Contact Positions	2 x 5 + 2, 3 x 16, 1 x 11, 1 x 7, 1 x 8
	Contact Resistance	15 milliohms max.
	Current Rating* (see note)	5.5 amperes @ 20°C max. (8456)
	Insulation Resistance	5,000 megohms min. at 500 VDC
	Dielectric Withstanding	1,550 VAC rms at sea level
	Operating Temperature	-65°C to +125°C
	Insulator Material	Polycarbonate (GF)
	Pin Contact Material	Copper alloy
	Wrap Post Dimension	N/A
	Contact Plating	DIN performance classes

*Current Rating: UL approval allows that DIN connectors up to 96 contacts be rated at 3 amperes. Over 96 pins must be derated to 1.0 ampere maximum VDE, CSA, and other European standards rate all DIN and DIN type connectors at 1 ampere maximum when they are on an 0.100 (2.54) x 0.100 (2.54) grid. (UL file # E27610 Vol. #1 Section #6)