

High Performance Miniature Circular Connectors

HR12 Series

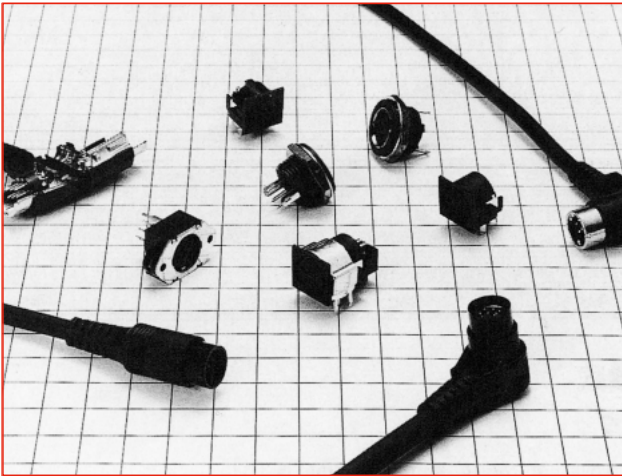

■ Features

- Snap lock allows for easy insertion and extraction and prevents the accidental un-mating of the connector due to vibration or impact.
- The plug diameter range from $\phi 12\text{mm}$ to $\phi 16\text{mm}$, and satisfies the need for small-size, light-weight and high-density electronic components.
- Equipped with internal metal parts and a shielding mechanism, the HR12 (20-contacts) and HR212 feature enhanced protection against EMI.

■ Product Specifications

Ratings	Rated voltage	Rated current	Operating temperature range	Storage temperature range
	100V AC, 140V DC	1A	-15°C to +60°C	-10°C to +60°C

Items	Specifications	Conditions
1. Contact resistance	30m Ω max. (excluding the cable conductor resistance)	Measured at DC 1mA
2. Insulation resistance	100M Ω min.	Measured at DC 250V
3. Withstanding voltage	No flashover or dielectric breakdown.	AC 300V for one minute
4. Vibration resistance	No electrical discontinuity for 10 μ s or greater.	10 to 55 Hz/cycle, amplitude- 0.75mm, 3 axis directions, 2 hours each
5. Shock resistance	No electrical discontinuity for 10 μ s or greater.	Acceleration: 490m/s ² , duration-11ms, 3 axis directions, 3 cycles each
6. Mating Cycles	30m Ω max. of contact resistance (excluding the cable conductor resistance)	1,000 times
7. Temperature cycle	Insulation resistance: a minimum of 100M Ω	-25°C: 30 minutes → Normal temperature: 10 to 15 minutes → 70°C: 30 minutes → Normal temperature: 10 to 15 minutes, left for 5 cycles
8. Moisture resistance	Insulation resistance: 1M Ω min. (at high humidity) 10M Ω min. (when dry)	Temperature: 40°C, relative humidity: 90 to 95%, left for 96 hours

■ Material / Finish

Part	Material	Finish
Insulator	Soft vinylchloride (UL94-0) and Polypropylene (UL94V-0) PBT resin (UL94V-0) and Polycarbonate (UL94V-1)	—
	Brass, and Zinc alloy	Tin plated and Nickel plated
Contacts	Copper alloy or phosphor bronze	Tin plated or selective gold plated and silver plated

■ Product Number Structure

● Cable Plug

HR12 **A** - **10** **L** **A** **A** **8** **P** **C** **A** **300** **A** (***)

①
②
③
④
⑤
⑥
⑦
⑧
⑨
⑩
⑪
⑫
⑬
⑭

● Plug (Assembly type) and Receptacle

HR12 - **10** **R** **C** - **8** **SDL** (**)

①
③
④
⑥
⑦
⑧
⑭

● Attachment

HR12 - **10** **R** - **SP** (**)

①
③
④
⑬
⑭

<p>① Model: Series name. HR212 is a enhanced shielding type.</p>
<p>② Indication of terminal connector provided or not: For models with connectors on both sides, different signs are used depending on the type of connector on one side.</p>
<p>③ Shell size: Indicates the outside diameter of the plug mating part.</p>
<p>④ Connector form: P: Straight plug LP or L: Right angle R: Receptacle</p>
<p>⑤ Cable removal directions for a right angle plug are classified as follows: A: The cable removal direction is on the right with the guide facing upward viewed from the mating part. B: The cable removal direction is on the left with the guide facing upward viewed from the mating part.</p>
<p>⑥ Types of connector : A connector with two or more varieties is classified by A, B, C,.....</p>
<p>⑦ Number of contacts</p>
<p>⑧ Contact form: Classifies the type of contacts as follows: The plug has only male contacts, and the receptacle has only female contacts. P: Male contact PC: Crimp male contact (assembly type plug) SC: Crimp female contact SD: Straight dip female contact SDL: Right angle dip female contact</p>
<p>⑨ Shape of cable: C: Curled cord S: Straight cord</p>
<p>⑩ Type of cable: Cables connected to the plug are identified by A, B, C,..... when they are different in construction and number of cores.</p>
<p>⑪ Cable length: indicates the length in mm of the cable connected to the plug. Curled cord length: Length of curled part Straight cable length: Cable length</p>
<p>⑫ Shape of cable end: Plugs with cables of the same shape but different in cable end dimensions and finishing are identified by A, B, C,.....</p>
<p>⑬ Types of accessories: SP: Stopper plate</p>
<p>⑭ Other specifications: A two-digit character is added to indicate other specifications as needed.</p>

HR12 Type

■ Right Angle Plug

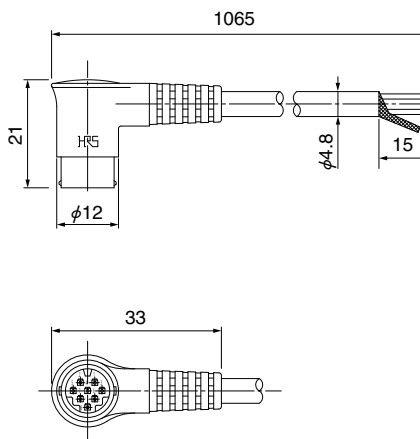

Part No.	HRS No.	No. of contacts	No. of conductors of cable	Remarks
HR12-10LA8PS1065(71)	112-3040-0 71	8	8-conductor (Shielded)	Straight cord Terminal tin plated

■ Straight Plug

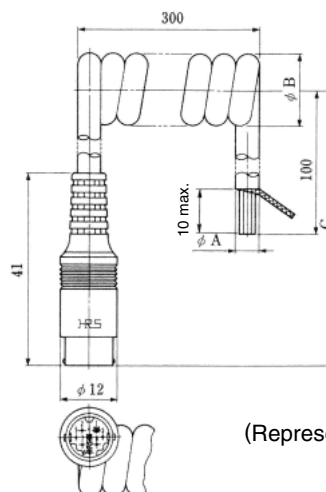

(Representative example)

Part No.	HRS No.	No. of contacts	φA	φB	C	No. of conductors of cable	Remarks
HR12-10P5PCD300(71)	112-0101-6 71	5	4.8	15	720	5-conductor (Shielded)	Curled cord Terminal tin plated
HR12-10P8PC300(71)	112-0102-9 71	8				8-conductor (Shielded)	
HR12-10P10PCAE300(71)	112-0133-2 71	10	5.5	17.5	700	10-conductor (Shielded)	Curled cord Terminal gold plated

■ Receptacle (Crimp Type)

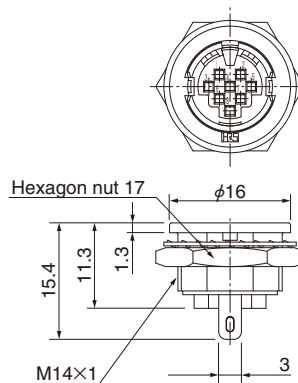

(Representative example)

Part No.	HRS No.	No. of contacts
HR12-10R-5SC(71)	112-0501-4 71	5
HR12-10R-8SC(71)	112-0504-2 71	8

Remarks: For the mounting holes, see page 4.

■ Receptacle (Straight Dip Type)



HR12-10R-8SD(71)

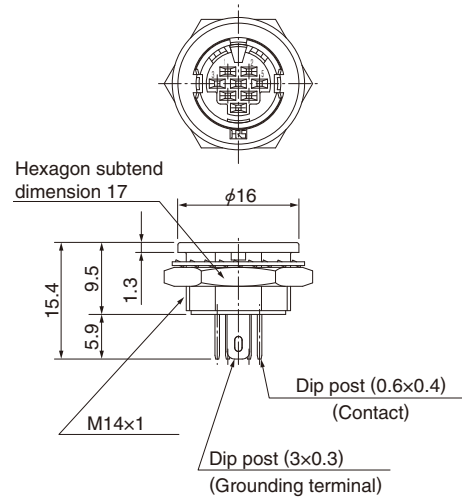

(Representative example)

Part No.	HRS No.	No. of contacts	Remarks
HR12-10R-5SD(71)	112-0502-7 71	5	Terminal tin plated
HR12-10R-8SD(71)	112-0505-5 71	8	

Remarks: Refer to following diagram for panel mounting dimensions and dip post arrangement dimensions.

◆ Panel mounting dimensions (Panel thickness 1 to 4.7)

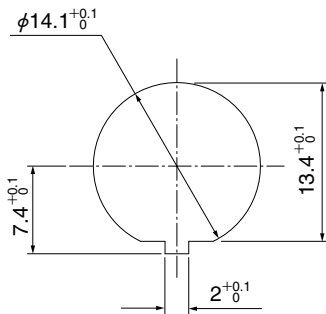

◆ Receptacle Dip Post

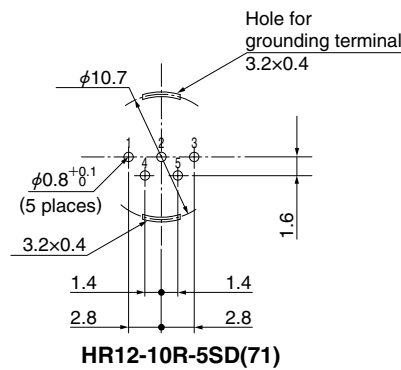

HR12-10R-5SD(71)

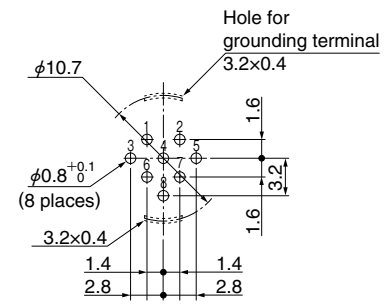

HR12-10R-8SD(71)

Remarks: Dimensional tolerance of $\pm 0.05\text{mm}$ is recommended for the board arrangement.

Receptacle(Right Angle Dip)

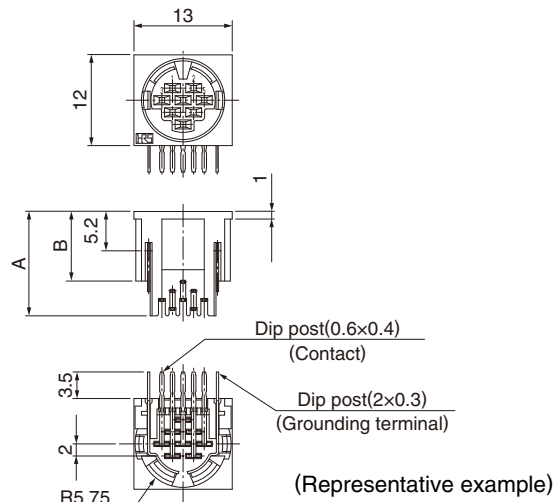

(Note)
This product should be mounted on the panel to hold with the interface portion, as shown in the panel mounting hole dimension diagram.
When it is difficult to press the connector into the panel, we recommend using the attached stopper plate HR12-10R-SP(71) (112-0507-0 71) as described on page 7.

Part No.	HRS No.	No. of contacts	A	B	Remarks
HR12-10R-5SDL(71)	112-0503-0 71	5	13	10.5	Terminal tin plated
HR12-10R-8SDL(71)	112-0506-8 71	8	13.8	9.3	
HR12-10RC-8SDL(71)	112-0514-6 71				Equipped with stopper plate Terminal tin plated

Remarks: For dip post arrangement see below figure.

Panel mounting dimensions

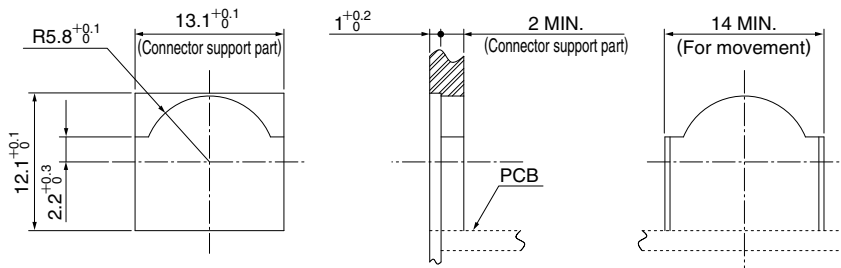

Note: Pay attention that this dimension is not available for 10 contacts.

Receptacle dip post arrangement

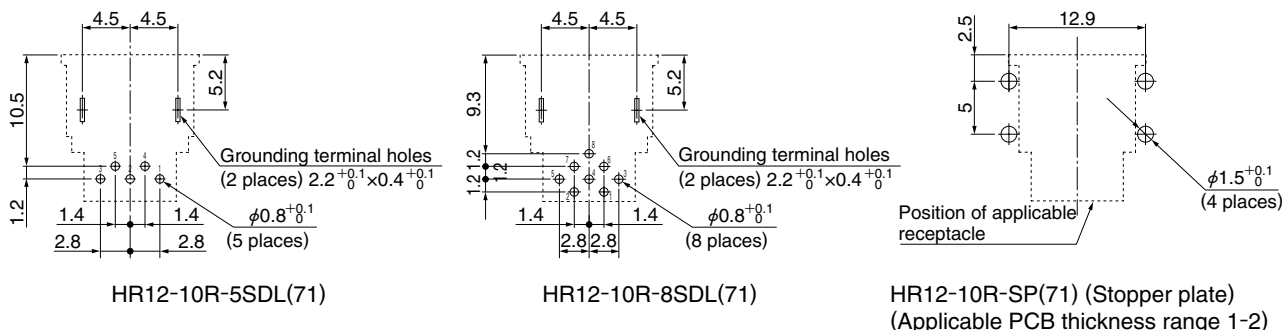

Remarks: Dimensional tolerance of $\pm 0.05\text{mm}$ is recommended for the board arrangement.

■ Receptacle (Right Angle Dip)

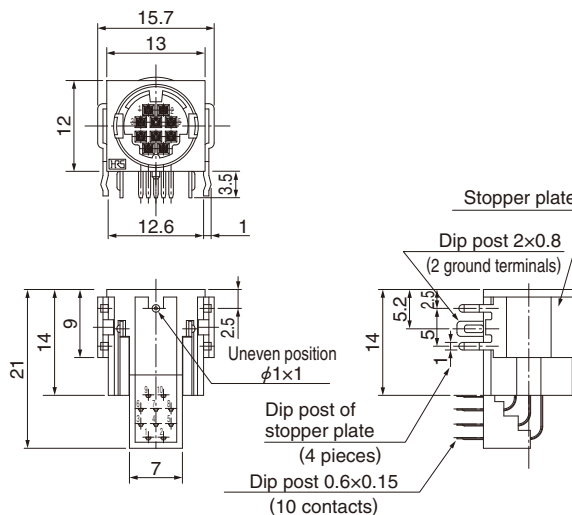

Part No.	HRS No.	No. of contacts	Remarks
HR12-10RC-10SDL(73)	112-0511-8 73	10	Color: Black Stopper plate Terminal gold plated

Remarks: For dip post arrangement see below figure.

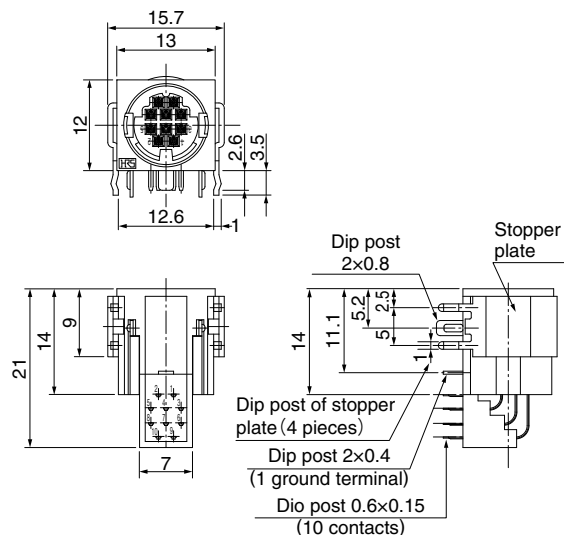

Part No.	HRS No.	No. of contacts	Remarks
HR12-10RD-10SDL(71)	112-0512-0 71	10	Color: Black Stopper plate Terminal gold plated

Remarks: For dip post arrangement see below figure.

◆ Receptacle dip post arrangement

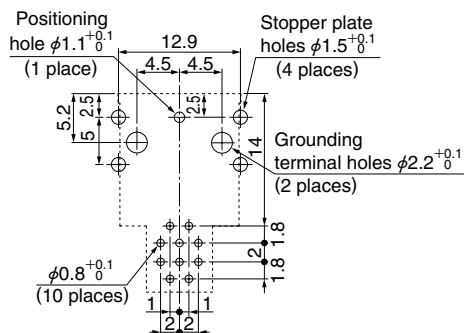

HR12-10RC-10SDL(73)

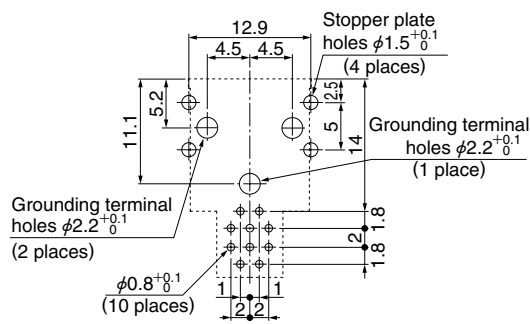

HR12-10RD-10SDL(71)

Remarks: Dimensional tolerance of $\pm 0.05\text{mm}$ is recommended for the board arrangement.

■ Stopper Plate

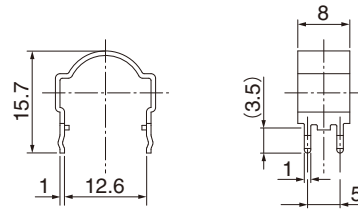
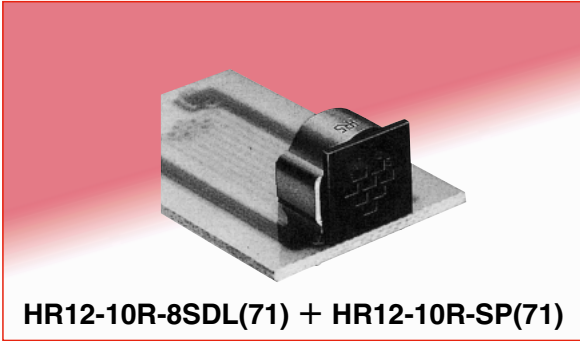

Part No.	HRS No.	Applicable connector	Applicable PCB thickness
HR12-10R-SP(71)	112-0507-0 71	HR12-10R-*SDL	t : 1 to 2

Remarks: 1. The *mark shows the number of pins.
2. For dip post arrangement, see page 5.

HR12 Type (20 contacts) /HR212 Type

■ Right Angle Plug (With straight)

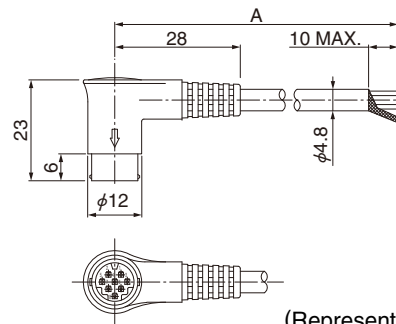

(Representative example)

Part No.	HRS No.	No. of contacts	A	No. of conductors of cable	Remarks
HR212-10LA8PSAT1028(72)	112-2120-1 72	8	1028	8-conductor (Shielded)	Color: Black Terminal: Selective gold plated
HR212-10LA8PSAT3028(72)	112-2121-4 72		3028		

Remarks: Cable can be taken-out only in direction A.

Right Angle Plug (Assembly Type)

Solder Type

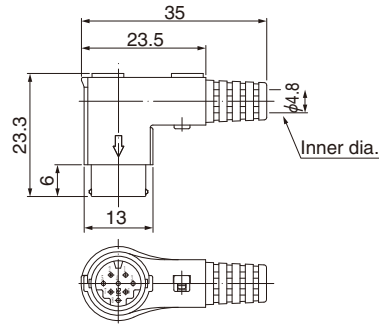

Part No.	HRS No.	No. of contacts	Remarks
HR212-10LP-8P(73)	112-4002-6 73	8	Color: Black Terminal: Selective gold plated
HR212-10LP-8P(74)	112-4002-6 74		Color: Sand beige Terminal: Selective gold plated

Remarks: Cable can be taken-out only in direction A.

Note: Because the cable clamping and rotational forces may vary with different cable types, it is recommended to verify the suitability of the cable assembly before use or production.

Crimp Type

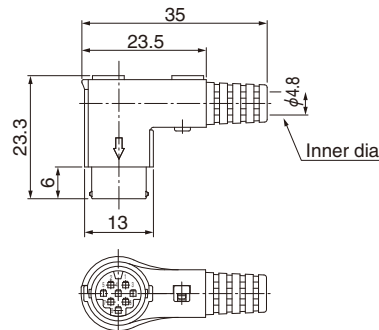

Part No.	HRS No.	No. of contacts	Remarks
HR212-10LP-8PC(71)	112-4101-8 71	8	Color: Black

Remarks: Cable can be taken-out only in direction A.

Note: Because the cable clamping and rotational forces may vary with different cable types, it is recommended to verify the suitability of the cable assembly before use or production.

Straight Plug (With straight cable)

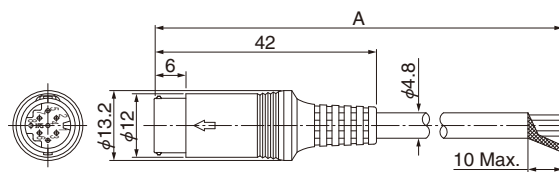

(Representative example)

Part No.	HRS No.	No. of contacts	A	No. of conductors of cable	Remarks
HR212-10P8PSAT1042(72)	112-2220-6 72	8	1042	8-conductor (Shielded)	Color: Black Terminal: Selective gold plated

■ Straight Plug (Assembly Type)

Solder Type

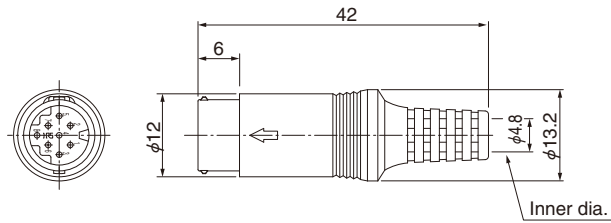

(Representative example)

Part No.	HRS No.	No. of contacts	Remarks
HR212-10P-8P(71)	112-4001-3 71	8	Color: Black Terminal: Tin plated
HR212-10P-8P(72)	112-4001-3 72		Color: Sand beige Terminal: Tin plated
HR212-10P-8P(73)	112-4001-3 73		Color: Black Terminal: Selective gold plated
HR212-10P-8P(74)	112-4001-3 74		Color: Sand beige Terminal: Selective gold plated

Note: Because the cable clamping and rotational forces may vary with different cable types, it is recommended to verify the suitability of the cable assembly before use or production.

Crimp Type

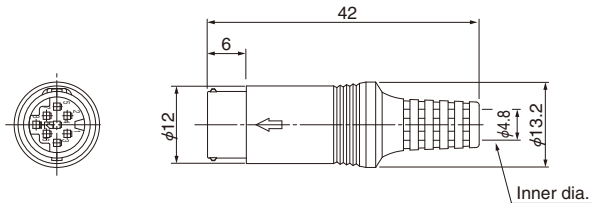

(Representative example)

Part No.	HRS No.	No. of contacts	Remarks
HR212-10P-8PC(71)	112-4051-1 71	8	-----
HR212-10P-8PC(72)	112-4051-1 72		Color: Sand beige
HR212-10P-10PC(71)	112-4052-4 71	10	-----
HR212-10P-10PC(72)	112-4052-4 72		Color: Sand beige

Note: Because the cable clamping and rotational forces may vary with different cable types, it is recommended to verify the suitability of the cable assembly before use or production.

■ Receptacle (Crimp Type)

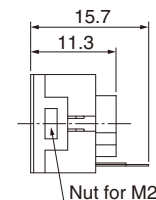
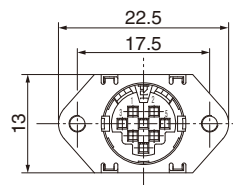

(Representative example)

Part No.	HRS No.	No. of contacts	Remarks
HR212-10R-8SC(71)	112-2001-2 71	8	-----

■ Receptacle (Straight Dip Type)

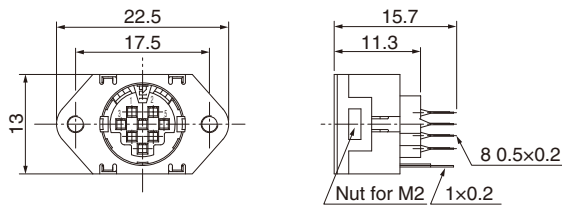

Part No.	HRS No.	No. of contacts	Remarks
HR212-10R-8SD(73)	112-2002-5 73	8	Color: Black Terminal: Tin plated
HR212-10R-8SD(74)	112-2002-5 74		Color: Black Terminal: Selective gold plated

Remarks: For dip post arrangement, see below figure.

■ Receptacle (Right Angle Dip Type)

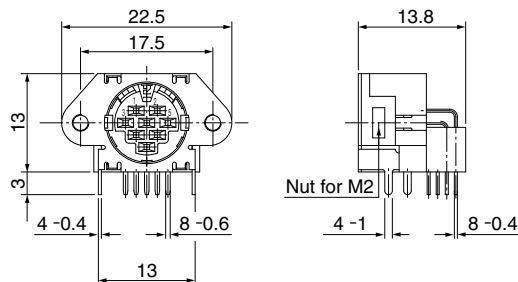

(Representative example)

Part No.	HRS No.	No. of contacts	Remarks
HR212-10R-8SDL(73)	112-2003-8 73	8	Color: Black Terminal: Tin plated
HR212-10R-8SDL(72)	112-2003-8 72		Color: Sand beige Terminal: Selective gold plated

Remarks: For dip post arrangement, see below figure.

◆ Receptacle Dip Post Layout

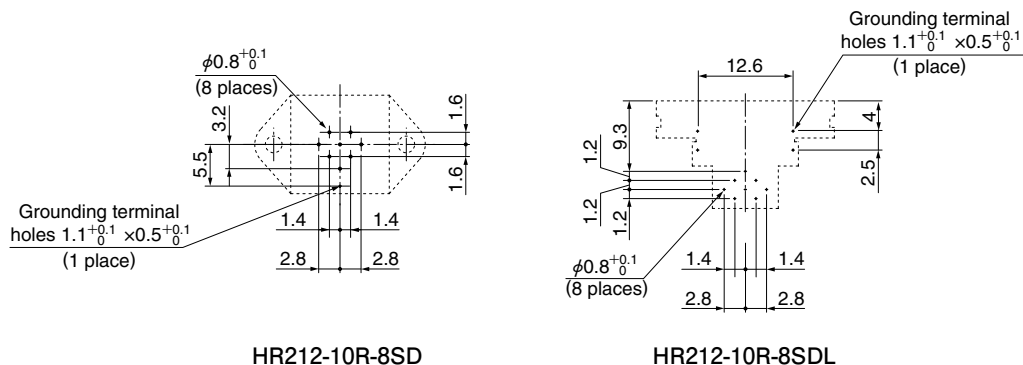

Remarks: Dimensional tolerance of $\pm 0.05\text{mm}$ is recommended for the board arrangement.

Receptacle (Right Angle Dip Type)

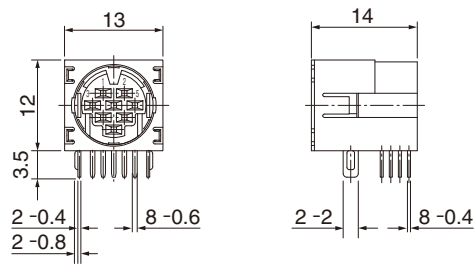

Part No.	HRS No.	No. of contacts	Remarks
HR212-10RA-8SDL(74)	112-2004-0 74	8	Color: Sand beige Terminal: Tin plated
HR212-10RA-8SDL(72)	112-2004-0 72		Color: Sand beige Terminal: Selective gold plated
HR212-10RA-8SDL(73)	112-2004-0 73		Color: Black Terminal: Selective gold plated

Remarks: For dip post arrangement, see below figure.

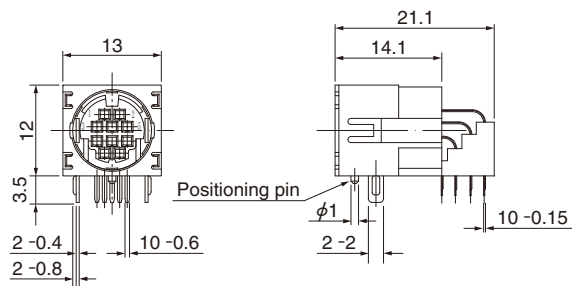

Part No.	HRS No.	No. of contacts	Remarks
HR212-10RC-10SDL(74)	112-2009-4 74	10	Color: Black Terminal: Selective gold plated

Remarks: For dip post arrangement, see below figure.

Receptacle Dip Post Layout

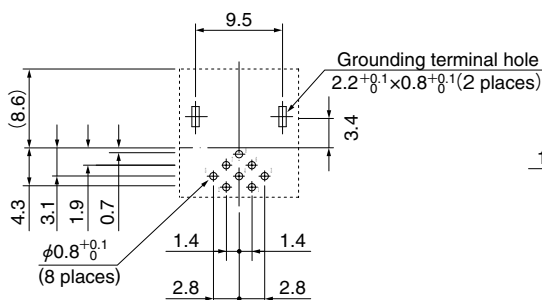

HR212-10RA-8SDL

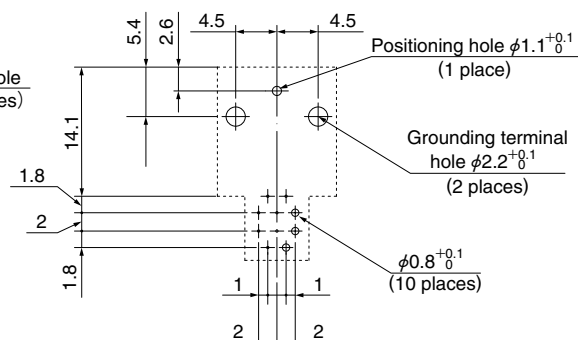

HR212-10RC-10SDL

Remarks: Dimensional tolerance of $\pm 0.05\text{mm}$ is recommended for the board arrangement.

■ Straight Plug

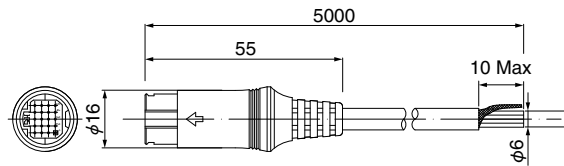

(Representative example)

Part No.	HRS No.	No. of contacts	No. of conductors of cable	Remarks
HR12-14P20PSD5000(71)	112-1105-2 71	20	20-conductor (Shielded)	Straight cord Terminal: silver plated

■ Right Angle Plug

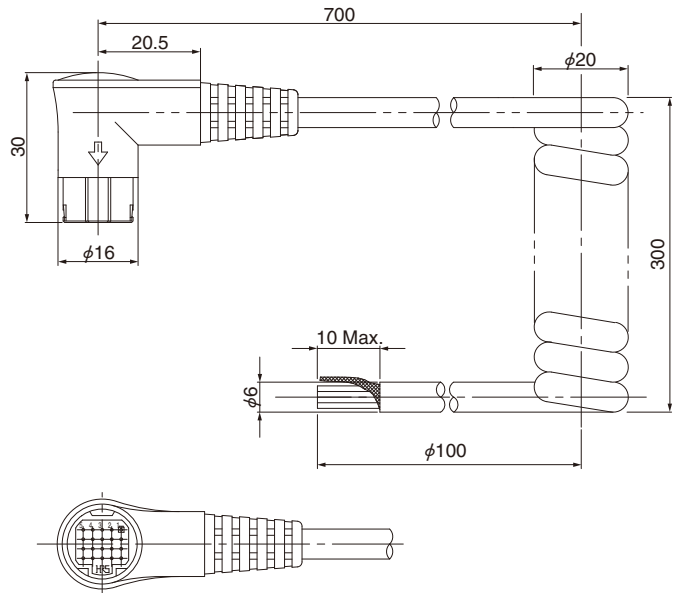

Part No.	HRS No.	No. of contacts	No. of conductors of cable	Remarks
HR12-14LA20PC300(71)	112-1001-7 71	20	20-conductor (Shielded)	Curled cord Terminal: silver plated

Remarks: Cable can be taken-out only in direction A.

■ Receptacle (Crimp Type)

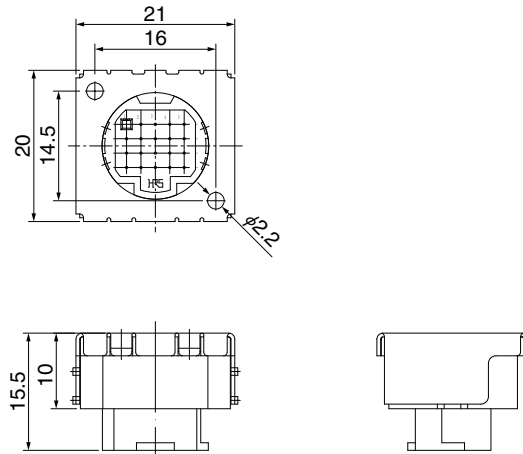

Part No.	HRS No.	No. of contacts	Remarks
HR12-14RA-20SC	112-1504-8	20	With hexagon nut

■ Receptacle (Right Angle Dip Type)

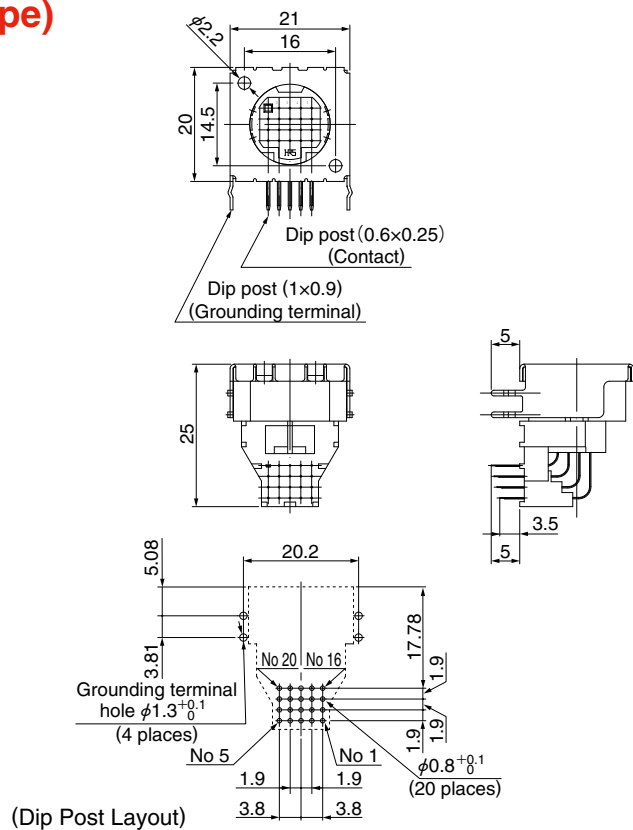

Part No.	HRS No.	No. of contacts	Remarks
HR12-14RA-20SDL	112-1502-2	20	With hexagon nut Terminal: silver plated

Remarks: Dimensional tolerance of $\pm 0.05\text{mm}$ is recommended for the board arrangement.

◆ Contact

● Female Contact

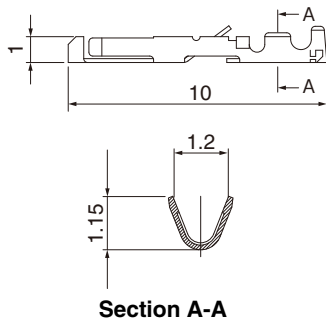

Section A-A

Type	Part No.	HRS No.	Plated	Applicable wire
Loose contacts	HR12-SC-111	112-0410-0	Selective gold plated	26 to 30 AWG
	HR12-SC-112	112-0411-3	Silver plated	
	HR12-SC-113	112-0412-6	Tin plated	
Reel contacts	HR12-SC-211	112-0407-6	Selective gold plated	
	HR12-SC-212	112-0408-9	Silver plated	
	HR12-SC-213	112-0409-1	Tin plated	

Note 1. Use cables with cable covering outer dia. ϕ 1mm or less.
 2. Loose piece contacts are packaged 100 pcs/pack.
 Reel contacts are packaged 10,000 pcs/reel.

● Male Contact

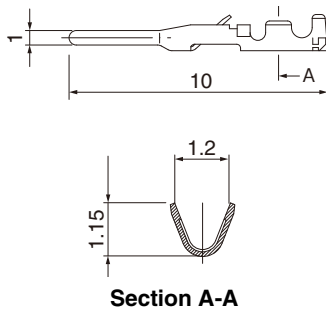

Section A-A

Type	Part No.	HRS No.	Plated	Applicable wire
Loose contacts	HR10-PC-111	110-0515-6	Selective gold plated	26 to 30 AWG
	HR10-PC-113(71)	110-0519-7 71	Tin plated	
Reel contacts	HR10-PC-211	110-0516-9	Selective gold plated	
	HR10-PC-213(71)	110-0520-6 71	Tin plated	

Note 1. Use cables with cable covering outer dia. ϕ 1mm or less.
 2. Loose piece contacts are packaged 100 pcs/pack.
 Reel contacts are packaged 10,000 pcs/reel.

◆ Applicable tools

Type	Item	Part No.	HRS No.	Applicable terminal	Applicable wire
Manual	Manual crimping tool	HR12-SC-TC	150-0052-9	HR10-PC- 111	26 to 30 AWG
				HR12-SC- 112 113	
Automatic	Automatic crimping machine body	CM-105C	901-0001-0	—————	—————
	Applicator	AP105-HR12-1	901-2015-9	HR10-PC- 211 213(71)	26 to 30AWG
Extraction tool		HR12-SC-TP	150-0050-3	HR12-SC- 111 112 113 211 212 213	
				RP6-SC-TP	150-0039-0



(HR12-SC-TC)
Hand Crimp Tool



(HR12-SC-TP) (RP6-SC-TP)
Extraction Tool



Auto Crimp Tool
CM-105C

◆ Cable Connecting Procedures

● Works Process

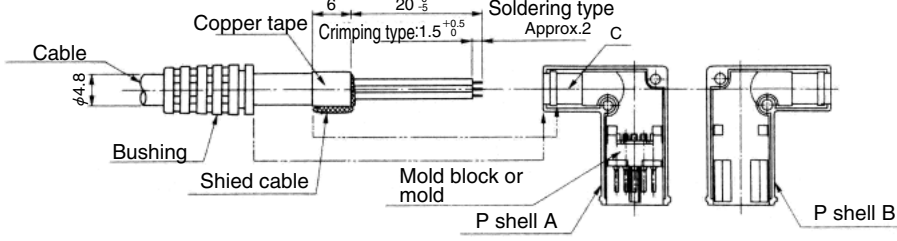
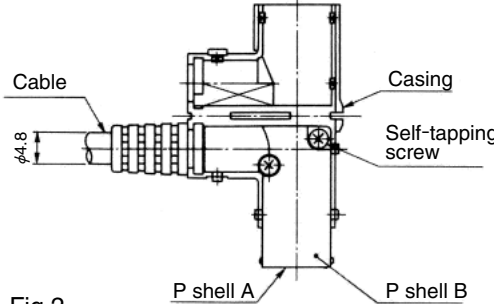
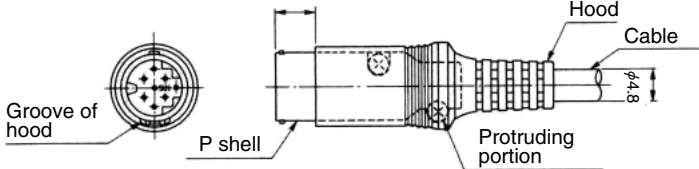
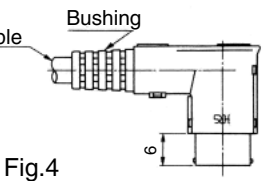
	Right-angle Plug	Straight Plug
1	Use cables of finished dia. 4.8mm and nominal conductor cross section of 0.129mm ² (AWG#26) and under. (Inner dia. of solder pot of soldering terminal is φ0.7mm.)	
2	Insert bushing over cable as shown in Fig.1.	Install hood over cable. Figure of straight type is omitted.
3	 <p>Fig.1</p> <p>Make cable end treatment to the dimensions shown in Fig.1. For shield cable, an example of cable end treatment is given below.</p> <p>(1) Firmly wrap the cable sheath end with copper tape 6mm wide, 16mm long and 85μm thick (overall thickness including adhesive).</p> <p>(2) Bundle up the shield cables, and tight twist. (Twist at least three turns over 6mm in length from the cable sheath tip)</p> <p>(3) Cut the shield cables at 6⁰.mm from the cable sheath tip, and fold back as shown in Fig.1.</p>	
4	<p>(Soldering Type) Solder cables to mold block into which terminals are assembled.</p> <p>(Crimping Type) Use applicable tool (HR12-SC-TC or CM-105) to crimp connect cables to applicable crimping terminals, then insert crimped terminals into mold and fix them to complete the mold block.</p>	
5	Assemble mold block having cables connected to location P shell A as shown in Fig.1. Carefully note that mold block and P shell A have directional polarization.	
6	Assemble bundled shield cables so that they are positioned at the center (C section) of cable outlet of P shell A as shown in Fig.1.	
7	<p>Install P shell B over P shell A as shown in Fig.2 and avoid catching of internal cables. Use the M2 self-tapping screws supplied (shape of screw head is phillip #0 for precision machinery) to secure from the direction of P shell B (2 places).</p>  <p>Fig.2.</p>	
8	<p>Move bushing to the end face of P shell, and put P shell and bushing into the casing as shown in Fig.2.</p>  <p>Fig.3</p>	<p>With groove of hood and protruding portion of P shell aligned, install hood over P shell as shown in Fig.3.</p>
9	<p>Install casing over P shell as shown in Fig.4.</p>  <p>Fig.4</p>	
10	Now assembling is completed.	

◆ Terminal Arrangement and performance

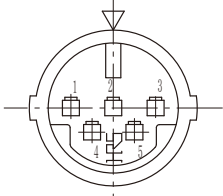
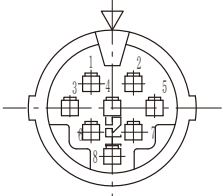
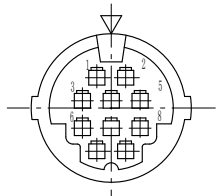
Shell size	10 sizes		
Terminal arrangement			
No. of contacts	5	8	10
Withstand voltage	300V AC for 1 minute		
Rated current	1A		
Insulation resistance	200MΩ or more at 250V DC		
Contact resistance	30mΩ or less (excluding cable conductor resistance)		

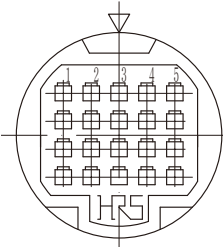
Shell size	14 sizes
Terminal arrangement	
No. of contacts	20
Withstand voltage	300V AC for 1 minute
Rated current	1A
Insulation resistance	200mΩ or more at 250V DC
Contact resistance	30mΩ or less (excluding cable conductor resistance)

Remarks: 1. The above figures show the receptacle pin inserts as viewed from the mating side.
 2. Withstand voltage shows the testing voltage.
 3. Contact resistance is as measured at 1A DC.



HIROSE ELECTRIC CO.,LTD.

2-6-3,Nakagawa Chuoh,Tsuzuki-Ku,Yokohama-Shi 224-8540,JAPAN
 TEL: +81-45-620-3526 Fax: +81-45-591-3726
<http://www.hirose.com>
<http://www.hirose-connectors.com>