

EXCELON® 74
Filter/Regulator-Lubricator Combination Units
3/8", 1/2", 3/4" Port Sizes

- **True modularity with Norgren Quikclamp™ connections**
- **Quick release bayonet bowl**
- **Lubricator flow sensor provides a nearly constant oil/air ratio over a wide range of air flows**
- **All around (360°) visibility of the lubricator sight-feed dome simplifies installation and adjustment**
- **Regulator balanced valve minimizes effect of variation in the inlet pressure on the outlet pressure**

Use Micro-Fog models in applications containing one or more points of lubrication.

Use Oil-Fog models to lubricate a single tool, cylinder, or other air driven device.



Technical Data

Fluid: Compressed air

Maximum pressure:

Transparent bowl: 10 bar (150 psig)

Metal bowl: 17 bar (250 psig)

Operating temperature*:

Transparent bowl: -20° to 50°C (0° to 125°F)

Metal bowl: -20° to 80°C (0° to 175°F)

* Air supply must be dry enough to avoid ice formation at temperatures below +2°C (+35°F).

Particle removal: 5 µm, 25 µm, or 40 µm filter element

Typical flow with 10 bar (150 psig) inlet pressure, 6,3 (90 psig) set pressure and 1 bar (15 psig) droop from set: **???** dm³/s (**???** scfm) *Waiting on lab test*

Manual drain connection: 1/8"

Automatic drain connection: 1/8"

Automatic drain operating conditions (float operated):

Bowl pressure required to close drain: Greater than 0,3 bar (5 psig)

Bowl pressure required to open drain: Less than 0,2 bar (3 psig)

Minimum air flow required to close drain: 1 dm³/s (2 scfm)

Manual operation: Depress pin inside drain outlet to drain bowl

Nominal bowl size:

Standard: 0,2 litre (7 fluid ounce)

Optional size for lubricator: 1 litre (1 quart US)

Gauge Ports:

1/4" PTF with PTF main ports

Rc 1/4 with ISO Rc main ports

Rc 1/8 with ISO G main ports

Recommended lubricants: See page N/AL.8.900.935

Materials:

Body: Aluminum

Bonnet: Aluminum

Filter/Regulator valve: Brass

Bowl:

Transparent: Polycarbonate with steel bowl guard

Metal: Aluminum

Metal bowl liquid level indicator lens:

0,2 litre (7 fluid ounce): Transparent nylon

1 litre (1 quart US): Pyrex

Sight-Feed dome: Transparent nylon

Element: Sintered plastic

Elastomers: Neoprene and nitrile

Ordering Information

See *Ordering Information* on the following pages.

ISO Symbol

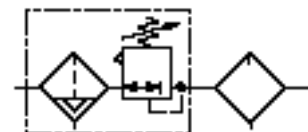

Filter with automatic drain, Regulator with relieving diaphragm, Lubricator with manual drain



EXCELON 74 F/R-L Combination Units

Ordering information. Models listed include Micro-Fog lubricator, ISO G threads, knob pressure adjustment, metal filter bowl with liquid level indicator and automatic drain, 40 µm filter element, relieving diaphragm, 10 bar (150 psig) regulating spring, no gauge, 0,2 litre (7 fluid oz.) metal lubricator bowl with liquid level indicator and 1/4 turn manual drain.

Combination Unit Type	Port Size	Model	Flow* dm ³ /s (scfm)	Weight kg (lb)
Filter/Regulator-Lubricator (F/R-L)	G3/8	C74H-3GK-AD3-RMN-QDN	?? (??) waiting on test	2,36 (5.20)
	G1/2	C74H-4GK-AD3-RMN-QDN	?? (??) waiting on test	2,30 (5.07)
	G3/4	C74H-6GK-AD3-RMN-QDN	?? (??) waiting on test	2,27 (5.00)

Alternative Models

★ 7 4 ★ - ★ ★ ★ - ★ ★ ★ - ★ ★ ★ - ★ ★ ★

Lockout Valve/ Quikmount	Substitute
Standard combination (no lockout valve or Quikmount)	C
With lockout valve on inlet	D
With Quikmount pipe adapters on inlet and outlet	E
With lockout valve on inlet and Quikmount pipe adapter on outlet	G

Combination Unit Type	Substitute
Standard Micro-Fog F/R-L	H
Standard Oil-Fog F/R-L	J
Micro-Fog F/R-L with porting block between filter/regulator and Lubricator	K
Oil-Fog F/R-L with porting block between filter/regulator and Lubricator	L

Port Size	Substitute
3/8"	3
1/2"	4
3/4"	6

Threads	Substitute
PTF	A
ISO Rc taper	B
ISO G parallel	G

Pressure Adjustment	Substitute
Knob	K
T-bar	T

Accessories	Substitute
Quikclamp wall brackets	B
Quikclamp wall brackets and lubricator quick fill nipple	C
No accessories	N
Lubricator quick fill nipple	Q

Lubricator Bowl	Substitute
1 litre (1 quart US) metal with liquid level indicator	A
0,2 litre (7 fluid oz.) metal with liquid level indicator	D
0,2 litre (7 fluid oz.) transparent with zinc guard	P

Lubricator Drain	Substitute
Closed bottom	E
Manual, 1/4 turn	Q
Remote fill †	R

Filter/Regulator Gauge	Substitute
With gauge	G
No gauge	N

Regulation spring *	Substitute
0,3 to 4 bar (5 to 60 psig)	F
0,3 to 10 bar (5 to 150 psig)	M
0,7 to 17 bar (10 to 250 psig)**	S

Filter/Regulator Diaphragm	Substitute
Non relieving	N
Relieving	R

Filter Element	Substitute
5 µm	1
25 µm	2
40 µm	3

Filter Bowl	Substitute
Metal with liquid level indicator	D
Transparent with guard	P

Filter Drain	Substitute
Automatic	A
Manual, 1/4 turn	Q

* Outlet pressure can be adjusted to pressures in excess of, and less than, those specified. Do not use these units to control pressures outside of the specified ranges.

** Units with 17 bar (250 psig) outlet pressure range are available only with the T-bar adjustment; therefore substitute **T** at the 7th position and **S** at the 12th position.

† Use remote fill only with 0,2 litre (7 fluid oz.) bowls.

Accessories. See page N/AL.8.200.700.



Dimensions mm (inches). See pages N/AL.8.200.300, N/AL.8.200.400, N/AL.8.200.600, and N/AL.8.200.700 for dimensions of individual products and the Quikclamp wall bracket.

**Standard Micro-Fog Type C74H-
Standard Oil-Fog Type C74J-**

Shown with optional gauge and Quikclamp wall bracket.

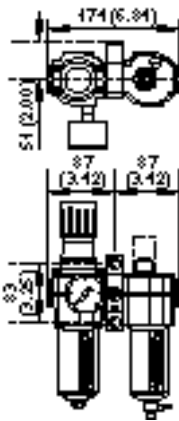

**Alternative Micro-Fog Type D74H-
Alternative Oil-Fog Type D74J-**

Includes lockout valve.
Shown with optional gauge and Quikclamp wall brackets.

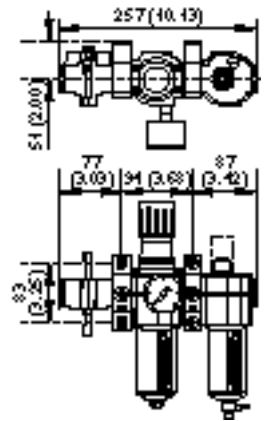

**Alternative Micro-Fog Type E74H-
Alternative Oil-Fog Type E74J-**

Includes Quikmount pipe adapters.
Shown with optional gauge and Quikclamp wall brackets.

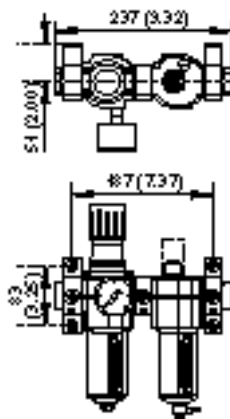

**Alternative Micro-Fog Type G74H-
Alternative Oil-Fog Type G74J-**

Includes lockout valve and Quikmount pipe adapter.
Shown with optional gauge and Quikclamp wall brackets.

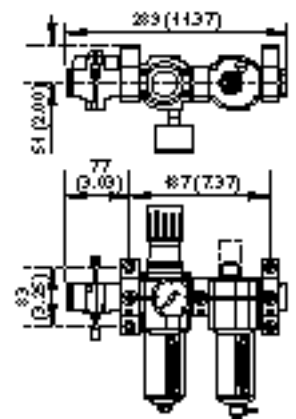

**Alternative Micro-Fog Type C74K-
Alternative Oil-Fog Type C74L-**

Includes porting block.
Shown with optional gauge and Quikclamp wall brackets.

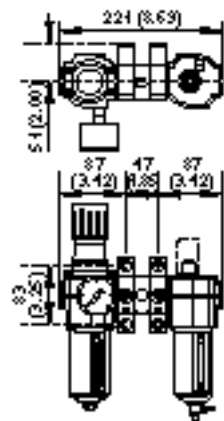

**Alternative Micro-Fog Type D74K-
Alternative Oil-Fog Type D74L-**

Includes lockout valve and porting block.
Shown with optional gauge and Quikclamp wall brackets.

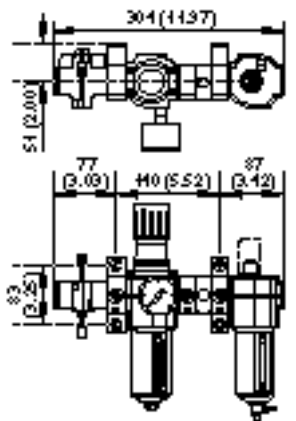

**Alternative Micro-Fog Type E74K-
Alternative Oil-Fog Type E74L-**

Includes Quikmount pipe adapters and porting block.
Shown with optional gauge and Quikclamp wall brackets.

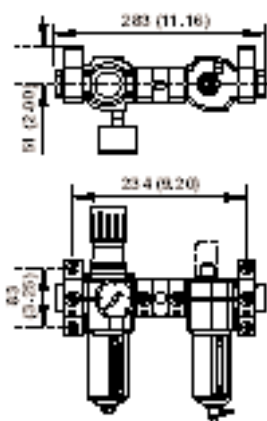

**Alternative Micro-Fog Type G74K-
Alternative Oil-Fog Type G74L-**

Includes lockout valve, Quikmount pipe adapter, and porting block.
Shown with optional gauge and Quikclamp wall brackets.

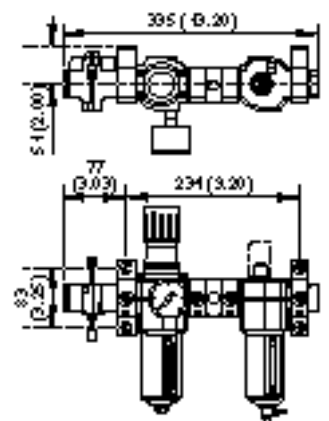



Typical Performance Characteristics

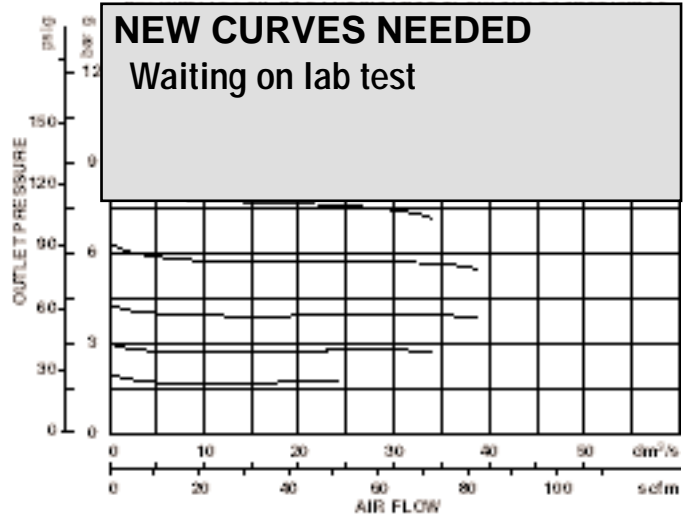
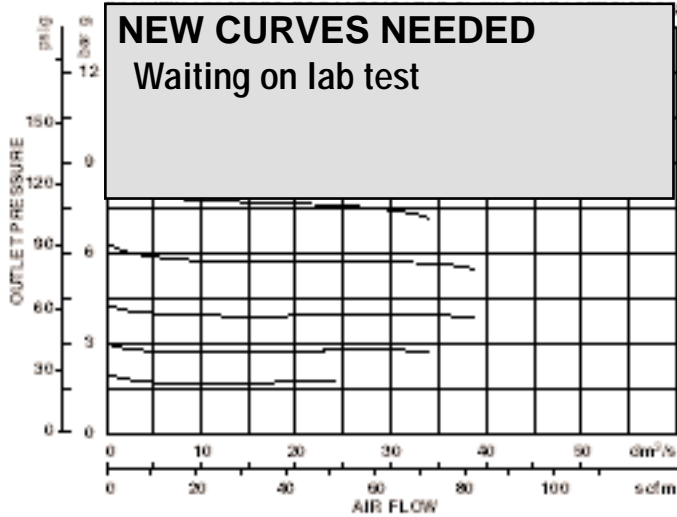

Warning

These products are intended for use in industrial compressed air systems only. Do not use these products where pressures and temperatures can exceed those listed under "Technical Data".

Before using these products with fluids other than those specified, for non-industrial applications, life-support systems, or other applications not within published specifications, consult Norgren.

Through misuse, age, or malfunction, components used in fluid power systems can fail in various modes. The system designer is warned to consider the failure modes of all component parts used in fluid power systems and to provide adequate safeguards to prevent personal injury or damage to equipment in the event of such failure.

System designers must provide a warning to end users in the system instructional manual if protection against a failure mode cannot be adequately provided.

System designers and end users are cautioned to review specific warnings found in instruction sheets packed and shipped with these products.