

# San Ace C270 9B1TS type

## Bracket-mounted Centrifugal Fans

### Features

#### Maximizes Strengths of the Centrifugal Fan

To maximize fan performance, an air inlet needs to be precisely mounted to the fan. Bracket-mounted centrifugal fan has an air inlet and a mounting bracket integrated in one unit. The precise assembly at factory ensures the optimized balance, helping the fan perform at its maximum potential.

#### Easy Installation

Centrifugal fan comes equipped with an air inlet and a mounting bracket, making your installation work easy.



**270 × 270 × 119 mm**

### Specifications

The following nos. have **PWM controls and pulse sensors.**

Model no.	Rated voltage [V]	Operating voltage range [V]	PWM duty cycle (Note 1, 2) [%]	Rated current [A]	Rated input [W]	Rated speed [min <sup>-1</sup> ]	Max. airflow [m <sup>3</sup> /min] [CFM]	Max. static pressure [Pa] [inchH <sub>2</sub> O]	SPL [dB(A)]	Operating temperature [°C]	Expected life [h]
9B1TS48P0G001	48	36 to 72	100	3.65	175.2	3,550	28.1 992	861 3.46	74.5	-20 to +60	40,000 / 60 °C (70,000 / 40 °C)
15			0.24	11.5	1,000	7.85 277	68.5 0.28	52.0			
9B1TS48P0H001			100	2.08	99.8	2,900	22.7 802	590 2.37	70.5	-20 to +70	
15			0.24	11.5	1,000	7.85 277	68.5 0.28	52.0			

Note 1 PWM frequency: 25 kHz

Note 2 Fans do not rotate when PWM duty cycle is 0%.

Note 3 Max input is 9B1TS48P0G001: 380 W, 9B1TS48P0H001: 200 W at rated voltage.

Models with the following sensor specifications are also available as options: **Without Sensor**

### Common Specifications

- Material ..... Motor case: Aluminum, Impeller: Plastics (Flammability: UL94V-0), Bracket: Aluminum, Plastics (Flammability: UL94V-0)
- Expected life ..... Refer to specifications  
(L10: Survival rate: 90% at 60 °C, rated voltage, and continuously run in a free air state)
- Motor protection system ..... Current blocking function and reverse polarity protection
- Dielectric strength ..... 50 / 60 Hz, 500 VAC, 1 minute (between lead conductor and bracket)
- Sound pressure level (SPL) ..... Expressed as the value at 1 m from air inlet side
- Operating temperature ..... Refer to specifications (Non-condensing)
- Storage temperature ..... -30 °C to +70 °C (Non-condensing)
- Lead wire ..... ⊕Red ⊖Black Sensor: Yellow Control: Brown
- Mass ..... Approx. 1,920 g

## Airflow - Static Pressure Characteristics

- PWM duty cycle

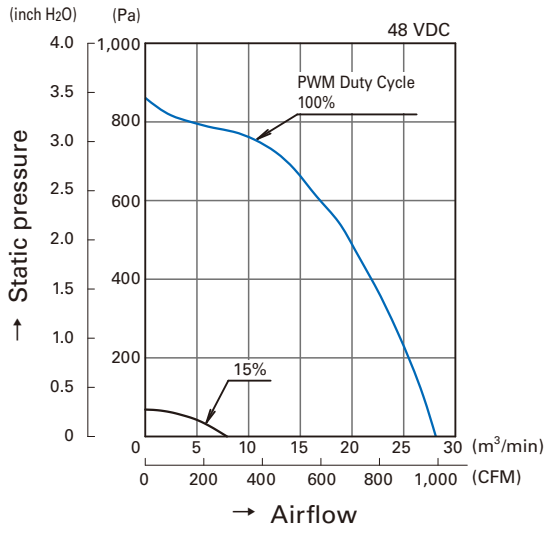

**9B1TS48P0G001**

- Operating voltage range

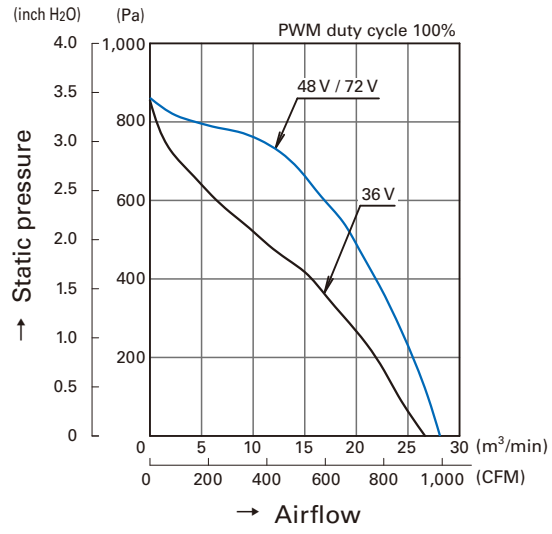

**9B1TS48P0G001**

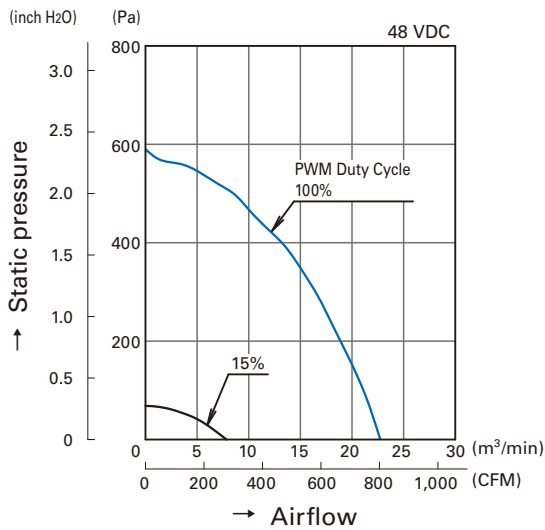

**9B1TS48P0H001**

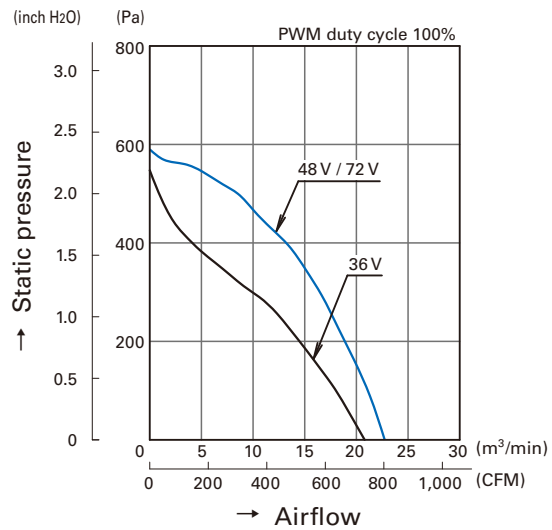

**9B1TS48P0H001**

## PWM Duty - Speed Characteristics Example

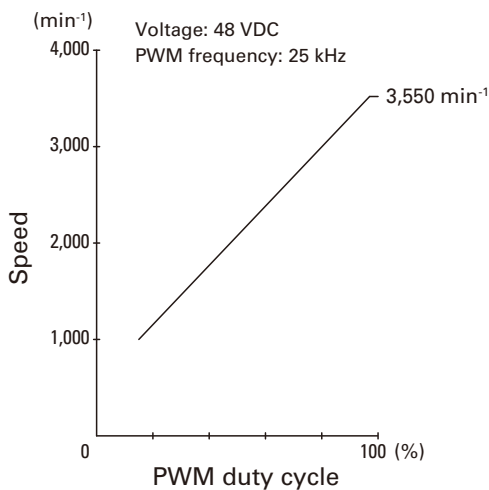

**9B1TS48P0G001**

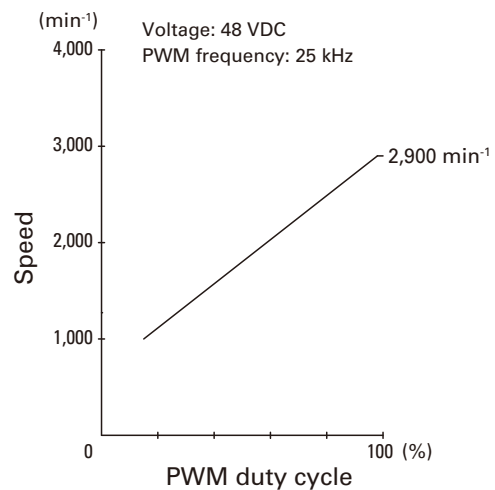

**9B1TS48P0H001**

### PWM Input Signal Example

Input signal waveform

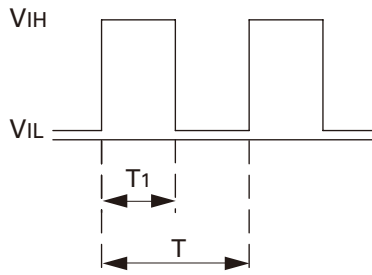

$V_{IH}=4.75\text{ V to }5.25\text{ V}$

$V_{IL}0\text{ V to }0.4\text{ V}$

$$\text{PWM duty cycle (\%)} = \frac{T_1}{T} \times 100$$

$$\text{PWM frequency } 25\text{ (kHz)} = \frac{1}{T}$$

Source current ( $I_{source}$ ): 1 mA max. at control voltage 0 V

Sink current ( $I_{sink}$ ): 1 mA max. at control voltage 5.25 V

Control terminal voltage: 5.25 V max. (Open circuit)

When the control lead wire is open, the fan speed is the same as the one at a PWM duty cycle of 100%.

Either TTL input, open collector or open drain can be used for PWM control input signal.

### Example of Connection Schematic

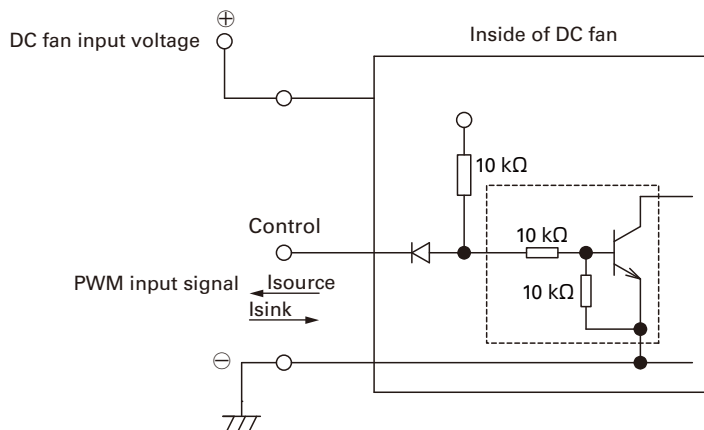

### Specifications for Pulse Sensors

Output circuit: Open collector

$V_{CE}=+72\text{ VDC max.}$

$I_c=10\text{ mA max. [}V_{CE}(\text{SAT}) = 1\text{ V max.]}$

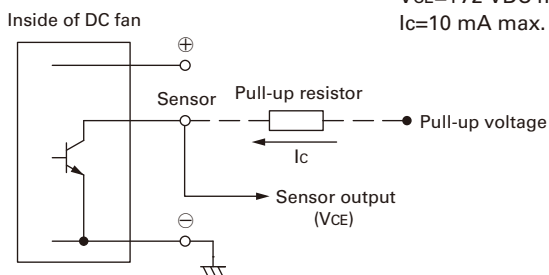

Output waveform (Need pull-up resistor)

In case of steady running

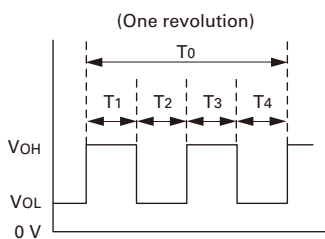

$$T_1 \text{ to } 4 \approx (1/4) T_0$$

$$T_1 \text{ to } 4 \approx (1/4) T_0 = 60/4N \text{ (sec)}$$

$N=\text{Fan speed (min}^{-1}\text{)}$

## Dimensions (unit: mm)

Fan

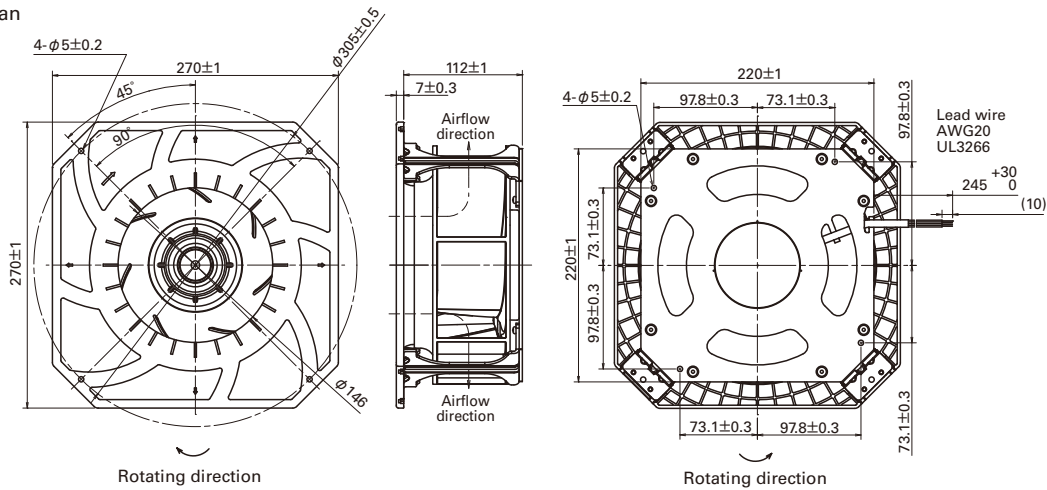

Finger guard (Model: 109-1146)

Surface treatment: Nickel-chrome plating  
(Color: silver)

Mass: 106 g

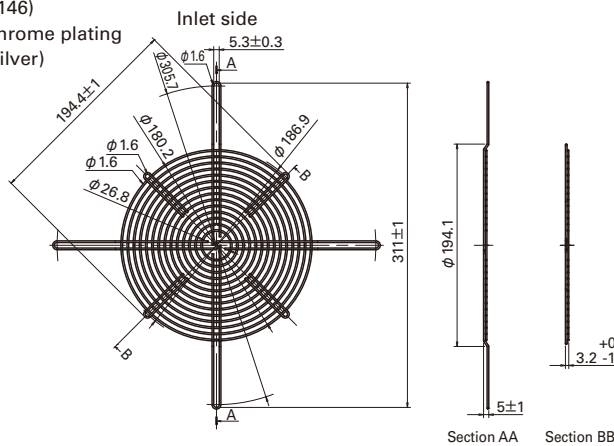

## Reference Dimensions of Mounting Holes and Vent Opening (unit: mm)

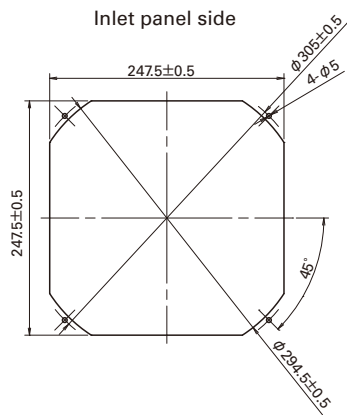

## Reference Diagram for Mounting

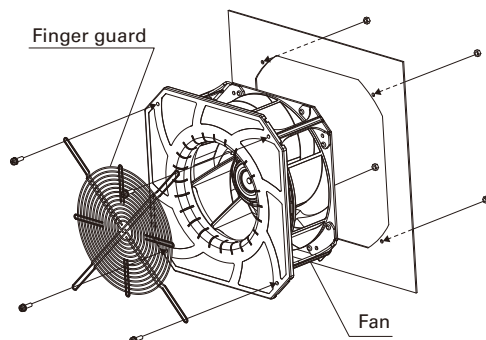

## Notice

- Please read the "Safety Precautions" on our website before using the product.
- The products shown in this catalog are subject to Japanese Export Control Law. Diversion contrary to the law of exporting country is prohibited.
- For protecting fan bearings against electrolytic corrosion near strong electromagnetic noise sources, we provide effective countermeasures such as Electrolytic Corrosion Proof Fans and EMC guards. Contact us for details.

**SANYO DENKI CO., LTD.** 3-33-1 Minami-Otsuka, Toshima-ku, Tokyo 170-8451, Japan TEL: +81 3 5927 1020

<http://www.sanyodenki.com>

The names of companies and/or their products specified in this catalog are the trade names, and/or trademarks and/or registered trademarks of such respective companies. "San Ace" is a trademark of SANYO DENKI CO., LTD.

Specifications are subject to change without notice.

CATALOG No. C1065B001 '16.8