

## General Description

The MAX40006 evaluation kit (EV kit) provides a proven design to evaluate the MAX40006 low-power, MOS-input operational amplifier (op amp) in a 6-bump wafer-level package (WLP). The EV kit circuit is preconfigured as a noninverting amplifier, but can easily be adapted to other topologies by changing a few components. Low-power, low-input  $V_{OS}$ , and rail-to-rail input/output stages make this device ideal for a variety of measurement applications. The component pads accommodate packages, making them easy to solder and replace. The EV kit comes with a MAX40006ANT+ installed.

## Features

- +1.7V to +5.5V Supply Voltage Range
- Accommodates Multiple Op-Amp Configurations
- Component Pads Allow for Sallen-Key Filter
- Rail-to-Rail Inputs/Outputs
- Proven PCB Layout
- Fully Assembled and Tested

[Ordering Information](#) appears at end of data sheet.

## Quick Start

### Required Equipment

- MAX40006 EV kit
- +5V, 10mA DC power supply (PS1)
- Precision voltage source
- Digital multimeter (DMM)

### Procedure

The EV kit is fully assembled and tested. Follow the steps below to verify board operation:

- 1) Verify that the jumpers are in their default positions, as shown in [Table 1](#).
- 2) Connect the positive terminal of the +5V supply to the  $V_{DD}$  PCB pad and the negative terminal to the GND PCB pad closest to  $V_{DD}$ .
- 3) Connect the positive terminal of the precision voltage source to the IN+ PCB pad. Connect the negative terminal of the precision voltage source to GND (GND or IN- PCB pads).
- 4) Connect the DMM to monitor the voltage on the OUT PCB pad. With the 10k $\Omega$  feedback resistor (R5) and 1k $\Omega$  series resistor (R1), the gain is +11 (noninverting configuration).
- 5) Turn on the +5V power supply.
- 6) Apply 100mV from the precision voltage source. Observe the output at OUT on the DMM. OUT should read approximately +1.1V.
- 7) Apply 400mV from the precision voltage source. OUT should read approximately +4.4V.

## Detailed Description of Hardware

The MAX40006 EV kit provides a proven layout for the MAX40006 low-power, MOS-input op amp. The device is a single-supply op amp that is ideal for buffering sensor signals. The Sallen-Key topology is easily accomplished by changing and removing some components. The Sallen-Key topology is ideal for buffering and filtering sensor signals.

### Op-Amp Configurations

The device is a single-supply op amp that is ideal for differential sensing, noninverting amplification, buffering, and filtering. A few common configurations are detailed in the next few sections.

#### Noninverting Configuration

The EV kit comes preconfigured as a noninverting amplifier. The gain is set by the ratio of R5/R1. The EV kit comes preconfigured for a gain of +11. For a voltage applied to the IN+ PCB pad, the output voltage for the noninverting configuration is given by the equation below:

$$V_{OUT} = \left(1 + \frac{R5}{R1}\right) (V_{IN+} + V_{OS})$$

where  $V_{OS}$  = Input-referred offset voltage.

#### Differential Amplifier

To configure the EV kit as a differential amplifier, replace R1, R2, R<sub>C3</sub>, and R5 with appropriate resistors. When R1 = R2 and R<sub>C3</sub> = R5, the CMRR of the differential amplifier is determined by the matching of resistor ratios R1/R2 and R<sub>C3</sub>/R5:

$$V_{OUT} = \text{Gain} (V_{IN+} - V_{IN-}) + \left(1 + \frac{R5}{R1}\right) V_{OS}$$

where:

$$\text{Gain} = \frac{R5}{R1} = \frac{R_{C3}}{R2}$$

### Sallen-Key Configuration

The Sallen-Key topology is ideal for filtering sensor signals with a 2nd-order filter and acting as a buffer. Schematic complexity is reduced by combining the filter and buffer operations. The EV kit can be configured in a Sallen-Key topology by replacing and populating a few components. The Sallen-Key topology is typically configured as a unity-gain buffer, which can be done by replacing R1 and R5 with 0Ω resistors. The signal is noninverting and applied to IN+. The filter component pads are R2, R3, R4, and R8, where some have to be populated with resistors and others with capacitors.

#### Lowpass Sallen-Key Filter

To configure the Sallen-Key as a lowpass filter, populate the R2 and R8 pads with resistors and the C3 and C4 pads with capacitors. The corner frequency and Q are then given by:

$$f_C = \frac{1}{2\pi\sqrt{R2 \times C3 \times R8 \times C4}}$$

$$Q = \frac{\sqrt{R2 \times C3 \times R8 \times C4}}{C4(R2 + R8)}$$

#### Highpass Sallen-Key Filter

To configure the Sallen-Key as a highpass filter, populate the C3 and C4 pads with resistors and the R2 and R8 pads with capacitors. The corner frequency and Q are then given by:

$$f_C = \frac{1}{2\pi\sqrt{C_{R8} \times R_{C4} \times C_{R2} \times R_{C3}}}$$

$$Q = \frac{\sqrt{C_{R8} \times R_{C4} \times C_{R2} \times R_{C3}}}{R_{R3}(C_{R2} + C_{R8})}$$

### Capacitive Loads

Some applications require driving large capacitive loads. To improve the stability of the amplifier in such cases, replace R6 with a suitable resistor value to improve amplifier phase margin in the presence of the capacitive load (C9), or apply a resistive load in parallel with C9.

**Table 1. Jumper Descriptions (JU1, JU2)**

JUMPER	SHUNT POSITION	DESCRIPTION
JU1	Installed*	Connects the IN- PCB pad to GND.
	Not installed	Isolates the IN- PCB pad from GND.
JU2	1-2*	Connects SHDN to V <sub>DD</sub> (normal operation).
	2-3	Connects SHDN to GND (shutdown).
JU3	Installed	Connects the IN+ PCB pad to GND.
	Not installed*	Isolates the IN+ PCB pad from GND.
JU4	Installed*	Connects V <sub>SS</sub> to GND.
	Not installed	Isolates V <sub>SS</sub> from GND.

\*Default position.

## Ordering Information

PART	TYPE
MAX40006EVKIT#	EV Kit

#Denotes RoHS compliant.

## MAX40006 EV Kit Bill of Materials

PART	QTY	DESCRIPTION
C1, C17	2	CAPACITOR; SMT (0402); CERAMIC CHIP; 0.1UF; 25V; TOL=10%; MODEL=C SERIES; TG=-55 DEGC TO +125 DEGC; TC=X7R
C2, C18	2	CAPACITOR; SMT (0603); CERAMIC CHIP; 4.7UF; 10V; TOL=10%; TG=-55 DEGC TO +125 DEGC; TC=X7S
IN+, IN-	2	TEST POINT; PIN DIA=0.125IN; TOTAL LENGTH=0.35IN; BOARD HOLE=0.063IN; WHITE; PHOSPHOR BRONZE WIRE SILVER PLATE FINISH;
JU1, JU3, JU4	3	CONNECTOR; MALE; THROUGH HOLE; BREAKAWAY; STRAIGHT THROUGH; 2PINS; -65 DEGC TO +125 DEGC
JU2	1	CONNECTOR; MALE; THROUGH HOLE; BREAKAWAY; STRAIGHT; 3PINS
OUT, VDD, OUT	3	TESTPOINT WITH 1.80MM HOLE DIA, RED, MULTIPURPOSE;
R1, R2	2	RESISTOR; 0402; 1K OHM; 1%; 100PPM; 0.063W; THICK FILM
R5	1	RESISTOR; 0402; 10K OHM; 1%; 100PPM; 0.063W; THICK FILM
R6, R8	2	RESISTOR; 0402; 0 OHM; 0%; JUMPER; 0.10W; THICK FILM
TP1-TP3	3	TEST POINT; PIN DIA=0.125IN; TOTAL LENGTH=0.445IN; BOARD HOLE=0.063IN; BLACK; PHOSPHOR BRONZE WIRE SILVER PLATE FINISH;
U1	1	EVKIT PART-IC; MAX40006ANT; OZ25; 4UA OPAMP WITH SHUT-DOWN; PACKAGE OUTLINE: 21-100086; PACKAGE CODE: N60D1-1; WLP6
VSS	1	TEST POINT; PIN DIA=0.125IN; TOTAL LENGTH=0.35IN; BOARD HOLE=0.063IN; YELLOW; PHOSPHOR BRONZE WIRE SILVER PLATE FINISH;
C3, C4, C8, C9	0	PACKAGE OUTLINE 0402 NON-POLAR CAPACITOR
R3, R7	0	PACKAGE OUTLINE 0402 RESISTOR
PCB	1	PCB Board:MAX40006 EVALUATION KIT

MAX40006 EV Kit Schematics

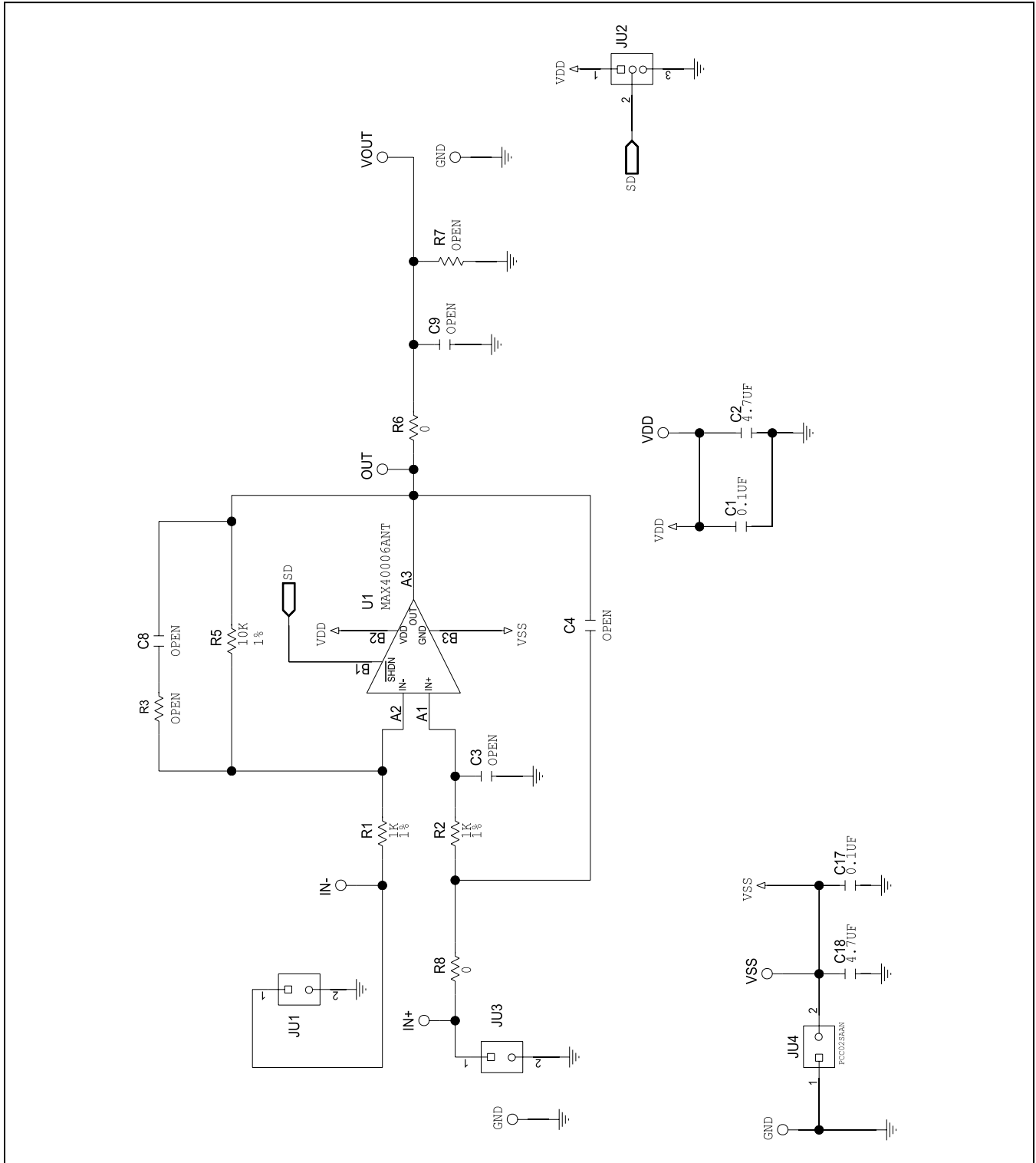

MAX40006 EV Kit PCB Layout

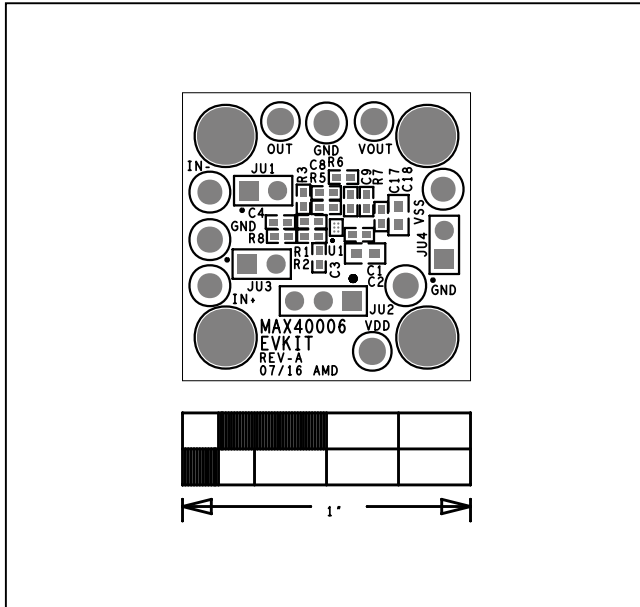

MAX4006 EV Kit—Top

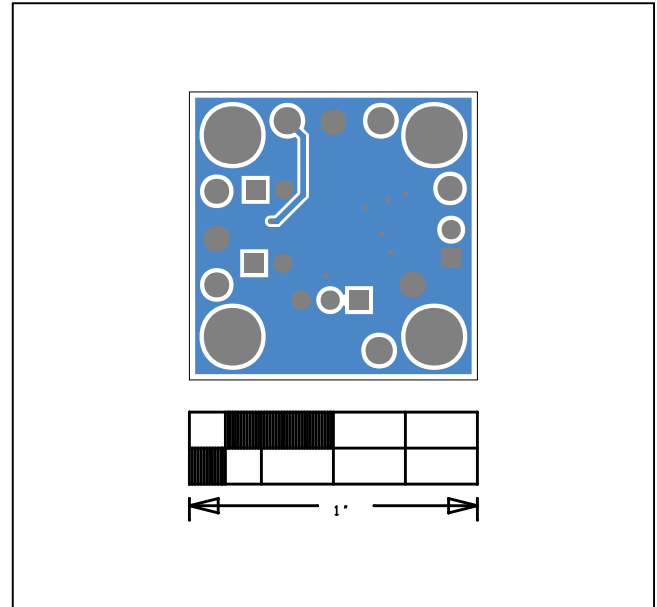

MAX4006 EV Kit—Bottom

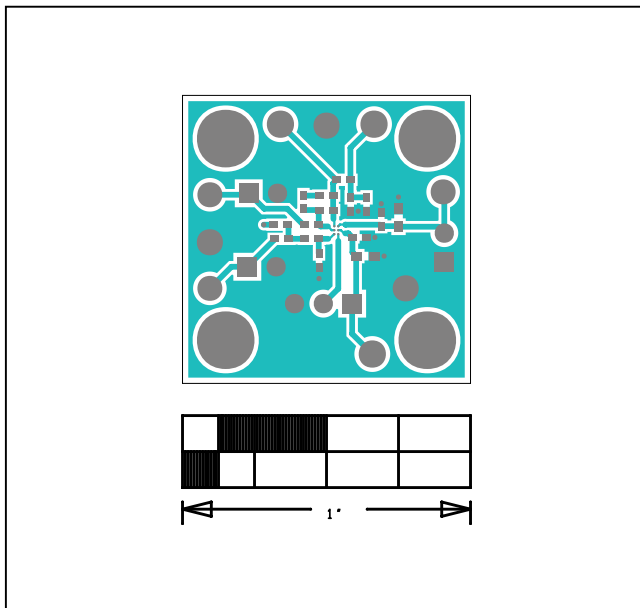

MAX4006 EV Kit—Top Silkscreen

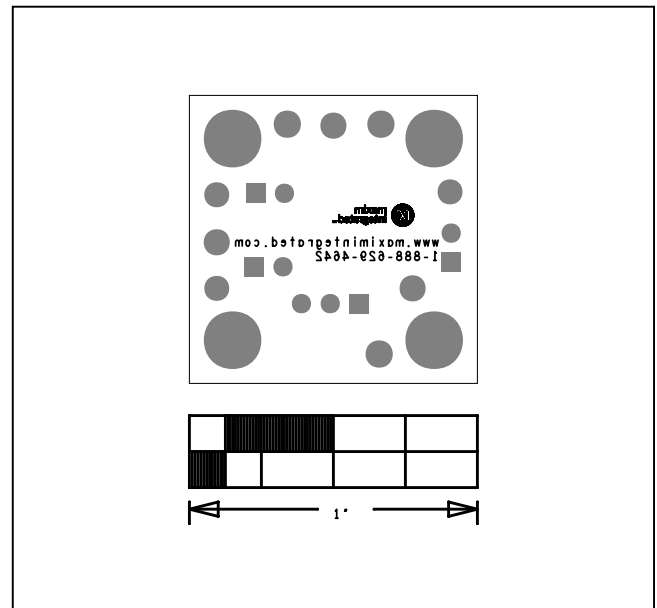

MAX4006 EV Kit—Bottom Silkscreen

### Revision History

REVISION NUMBER	REVISION DATE	DESCRIPTION	PAGES CHANGED
0	10/16	Initial release	—

For pricing, delivery, and ordering information, please contact Maxim Direct at 1-888-629-4642, or visit Maxim Integrated's website at [www.maximintegrated.com](http://www.maximintegrated.com).

*Maxim Integrated cannot assume responsibility for use of any circuitry other than circuitry entirely embodied in a Maxim Integrated product. No circuit patent licenses are implied. Maxim Integrated reserves the right to change the circuitry and specifications without notice at any time.*