



Intel[®] RealSense[™] Camera R200

Embedded Infrared Assisted Stereovision 3D Imaging System with Color Camera

Product Datasheet

R200 Intel Production Part Number: MM#939143

†(X) Numeric characters representing configuration or programmed firmware at manufacturing

June 2016

Revision 001



You may not use or facilitate the use of this document in connection with any infringement or other legal analysis concerning Intel products described herein. You agree to grant Intel a non-exclusive, royalty-free license to any patent claim thereafter drafted which includes subject matter disclosed herein.

No license (express or implied, by estoppel or otherwise) to any intellectual property rights is granted by this document.

Intel technologies' features and benefits depend on system configuration and may require enabled hardware, software or service activation. Learn more at Intel.com, or from the OEM or retailer.

No computer system can be absolutely secure. Intel does not assume any liability for lost or stolen data or systems or any damages resulting from such losses.

The products described may contain design defects or errors known as errata which may cause the product to deviate from published specifications. Current characterized errata are available on request.

Intel disclaims all express and implied warranties, including without limitation, the implied warranties of merchantability, fitness for a particular purpose, and non-infringement, as well as any warranty arising from course of performance, course of dealing, or usage in trade.

Intel technologies' features and benefits depend on system configuration and may require enabled hardware, software or service activation. Learn more at intel.com, or from the OEM or retailer.

All information provided here is subject to change without notice. Contact your Intel representative to obtain the latest Intel product specifications and roadmaps.

Copies of documents which have an order number and are referenced in this document may be obtained by calling 1-800-548-4725 or visit www.intel.com/design/literature.htm.

By using this document, in addition to any agreements you have with Intel, you accept the terms set forth below.

Contact your local Intel sales office or your distributor to obtain the latest specifications and before placing your product order.

Intel, Intel RealSense and the Intel logo are trademarks of Intel Corporation in the U.S. and/or other countries.

*Other names and brands may be claimed as the property of others.

Copyright © 2016, Intel Corporation. All rights reserved.

Contents

1	Description and Features	9
2	Overview	10
	2.1 R200 Description	10
	2.2 R200 Camera Module	11
	2.3 Components.....	12
	2.4 Storage and Operating Conditions.....	13
	2.5 Handling Conditions	13
3	Component Specification	15
	3.1 Imaging.....	15
	3.1.1 Color Imaging System.....	15
	3.1.2 Infrared Imaging System.....	15
	3.2 Infrared Light Projection	16
	3.3 Activity LED	17
	3.4 Temperature Sensor.....	17
	3.5 Camera Module Connector	17
	3.6 Other Components.....	18
4	Functional Specification	19
	4.1 Embedded 3D Imaging System.....	19
	4.2 Camera Video Stream Formats	19
5	Firmware	21
	5.1 Firmware Update (Windows* Only)	21
	5.2 Infrared Camera Functions.....	21
	5.3 Color Camera Functions R200.....	21
6	System Interoperability	23
	6.1 USB Composite Device	23
	6.1.1 Device Endpoints.....	23
	6.2 Power States.....	24
	6.2.1 Power Consumption	24
7	System Integration	25
	7.1 Integration Overview.....	25
	7.2 Module Stability.....	25
	7.3 Camera Module Dimensions	27
	7.4 Camera Module Mass.....	27
	7.5 Grounding.....	27
	7.6 Motherboard Receptacle	27
	7.7 Shielding	28
	7.8 Rear Cover Design Guidance	29
	7.8.1 Transparent Cover Material.....	29
	7.8.2 Gaskets.....	30
	7.8.3 Optical Isolation	30
	7.8.4 Dust Protection	32

7.9	Thermal Design Guidance	32
7.9.1	Thermal Limits	33
7.9.2	Thermal Management	34
7.10	Motherboard Routing Considerations	36
7.10.1	Cable TX to RX Crossover	37
7.10.2	Power Gate Circuit	37
7.10.3	Platform Specific Routing Guidance	38
7.10.4	Motherboard Receptacle	38
7.10.5	High Speed Cable Assembly	39
8	Calibration	41
9	System BIOS	42
9.1	UPC (USB Port Capabilities).....	42
9.2	PLD (Physical Device Location)	42
10	Packaging and Labeling	44
11	Regulatory Compliance R200.....	45
12	R200 Interconnect Cable Drawings	47
13	R200 Connector Drawings.....	48
14	Schematic Checklist	50

List of Figures

Figure 1-1. R200 Module Assembly	9
Figure 2-1. Example Color Stream	10
Figure 2-2. Example Depth Stream	11
Figure 2-3. R200 Module Form Factor	11
Figure 2-4. Component Locations (Front View)	13
Figure 3-1. Infrared Projector.....	16
Figure 4-1. Active Stereo Technology Overview	19
Figure 6-1. USB Composite Device Hardware ID	23
Figure 7-1. Z Direction Module Flex Example.....	25
Figure 7-2. Y Direction Module Flex Example	26
Figure 7-3. Twist Module Flex Example.....	26
Figure 7-4. Receptacle Ground Bar Motherboard Connections	28
Figure 7-5. Example IR Transmission of Acceptable Cover Material	30
Figure 7-6. Example of Light Leakage Effects	31
Figure 7-7. Example of Gasket Material Placement	32
Figure 7-8. Example of Separated Windows for Cover Material	32
Figure 7-9. System Component Placement	33
Figure 7-10. Module Thermal Probe Points	33
Figure 7-11. Module Thermal Solution Chassis or Frame Mount	35
Figure 7-12. Module Mounting Chassis or Frame	35
Figure 7-13. Module Thermal Solution Rear Cover Mount	35
Figure 7-14. Module Mounting Rear Cover	36
Figure 7-15. Example of Host Platform Motherboard Routing.....	37
Figure 7-16. Module Platform Power Gate Example	38
Figure 7-17. System Receptacle Properties	38
Figure 9-1. UPC Return Package Values.....	42
Figure 9-2. PLD System Design Considerations.....	43
Figure 10-1. Camera Module Label.....	44
Figure 12-1. Cable Mechanical Drawing	47
Figure 13-1. R200 Receptacle Mechanical Drawing.....	48
Figure 13-2. R200 Interconnect Plug Mechanical Drawing	49

List of Tables

Table 2-1. Component Descriptions.....	12
Table 2-2. Storage and Operating Conditions	13
Table 2-3. Electrostatic Discharge Caution	14
Table 3-1. Color Camera Properties.....	15
Table 3-2. Infrared Camera Properties.....	15
Table 3-3. Infrared Projector Parameters	16
Table 3-4. Module Receptacle Pinout	17
Table 3-5. Camera Module Functional Components	18
Table 4-1. Supported Left/Right Infrared Camera Video Stream Formats and Modes	19
Table 4-2. Supported Color Camera Video Stream Formats and Modes	20
Table 4-3. Supported Depth Video Stream Formats and Modes.....	20
Table 5-1. Left and Right IR Sensor Configuration.....	21
Table 5-2. RGB Sensor Configuration	21
Table 6-1. USB Composite Device Endpoints	23
Table 6-2. Device Power States	24
Table 6-3. Typical Power Consumption	24
Table 7-1. Module Bend and Twist Limits	27
Table 7-2. Component Case Temperature Limits.....	33
Table 7-3. Component Case Temperature vs. Junction Temperature	34
Table 7-4. Thermal Sensor vs. Laser Projector Junction Temperature	34
Table 7-5. Copper Foil Recommendation.....	36
Table 7-6. Heat Spreader Recommendation	36
Table 7-7. Receptacle Pin Out	38
Table 7-8. Receptacle Characteristics	39
Table 7-9. Plug Characteristics	39
Table 7-10. Cable Assembly Specification	39
Table 7-11. Cable Assembly Interconnect Properties	40
Table 9-1. UPC Elements	42
Table 9-2. PLD Elements.....	42
Table 9-3. PLD Return Package Values	43
Table 10-1. Scan Code Fields	44
Table 12-1. Cable Part Numbers	47
Table 14-1. Motherboard Connector Signals.....	50
Table 14-2. USB_RX Motherboard Signals.....	50
Table 14-3. USB_TX Motherboard Signals.....	50
Table 14-4. Power Signals	51

Additional References

Reference document	Document Number
Intel® RealSense™ Camera R200 3D CAD Files	334617-001

Revision History

Revision Number	Description	Revision Date
001	<ul style="list-style-type: none"><li data-bbox="479 548 673 588">• Initial Release	June 2016

§ §

1 Description and Features

Figure 1-1. R200 Module Assembly

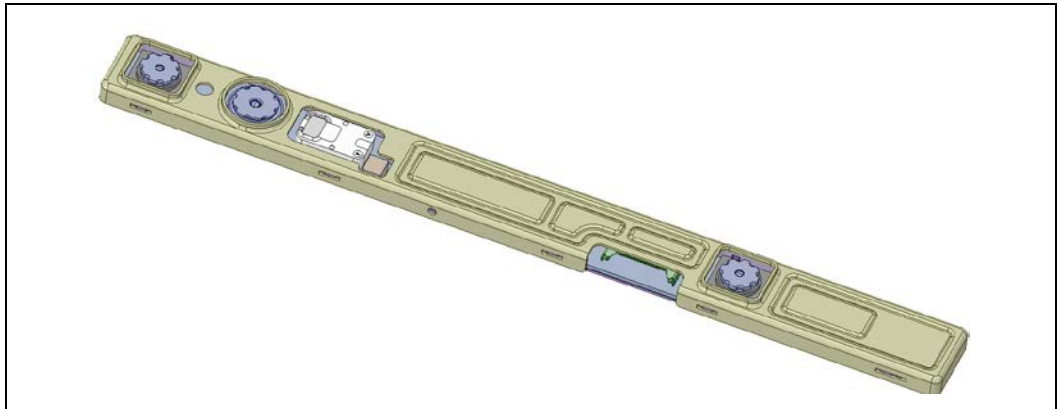

R200 Description

The Intel® RealSense™ Camera R200 is a module that implements a long range, stereovision 3D imaging system.

The small size of the R200 module provides system integrators flexibility to design into a wide range of products.

Features

- Onboard Imaging ASIC.
- VGA resolution depth capture from 0.4 to 2.8m⁽¹⁾
- Infrared (IR) Laser Projector System (Class 1)
- Dimensions 101.56mm length x 9.55mm height x 3.8mm width.
- Full HD RGB color stream.

⁽¹⁾ Software may optimize within this range.

Minimum System Requirements

- 1GB Disk Storage Space⁽¹⁾
- 2GB Memory⁽¹⁾
- USB3
- R200 Interconnect Cable⁽²⁾

⁽¹⁾ Additional disk space and memory may be required for certain applications. Refer to application minimum requirements.

⁽²⁾ Provided by the system integrator. Cable design is specific to system definition and meets R200 cable design specifications.

⁽³⁾ Contact local Intel representative for latest OS and platform support.



2 Overview

2.1 R200 Description

The R200 camera is a USB 3.0 device that can provide color, depth, and infrared video streams. Depth video streams are like color video streams, except each pixel has a value representing the distance away from the camera instead of color information. It consists of an infrared laser projection system, two infrared and a full HD color imaging sensors. The depth video stream is generated with stereo vision technology assisted by the Infrared laser projector and the two infrared imaging sensors. Color data is provided by the full HD color imaging sensor. The R200 module is not intended to be the primary photography solution. It has the ability to synchronize with a high resolution world facing camera for depth + photography applications.

Figure 2-1. Example Color Stream

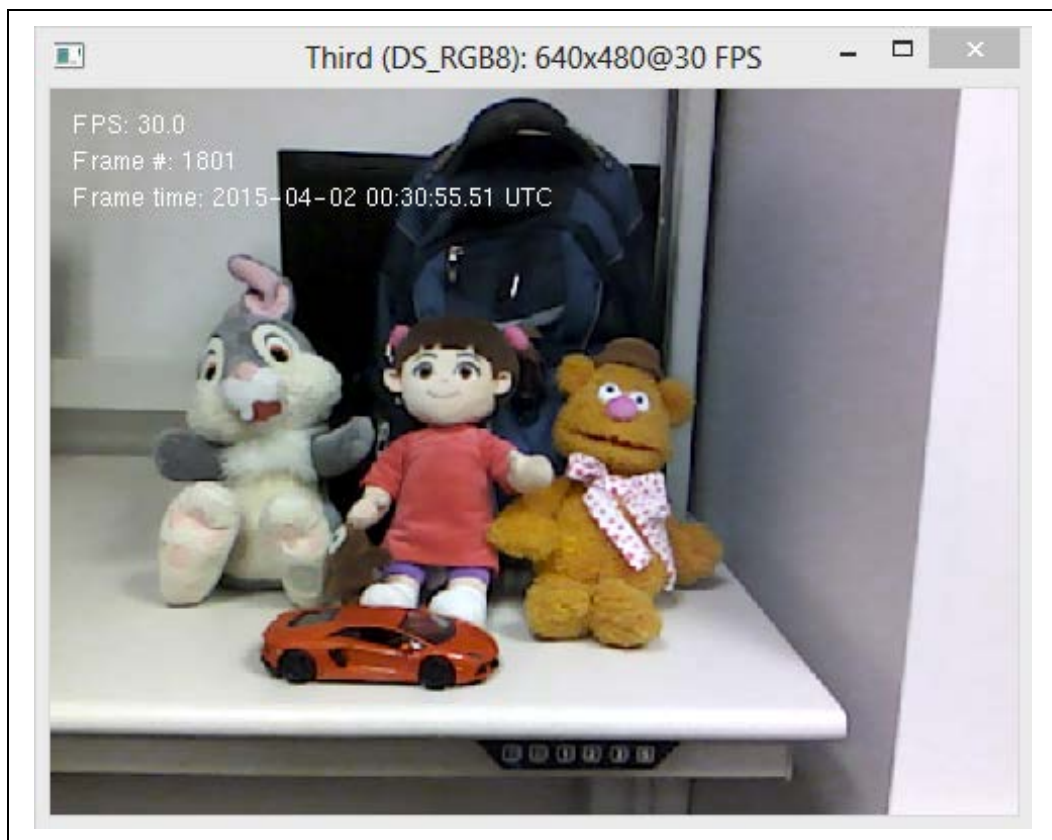
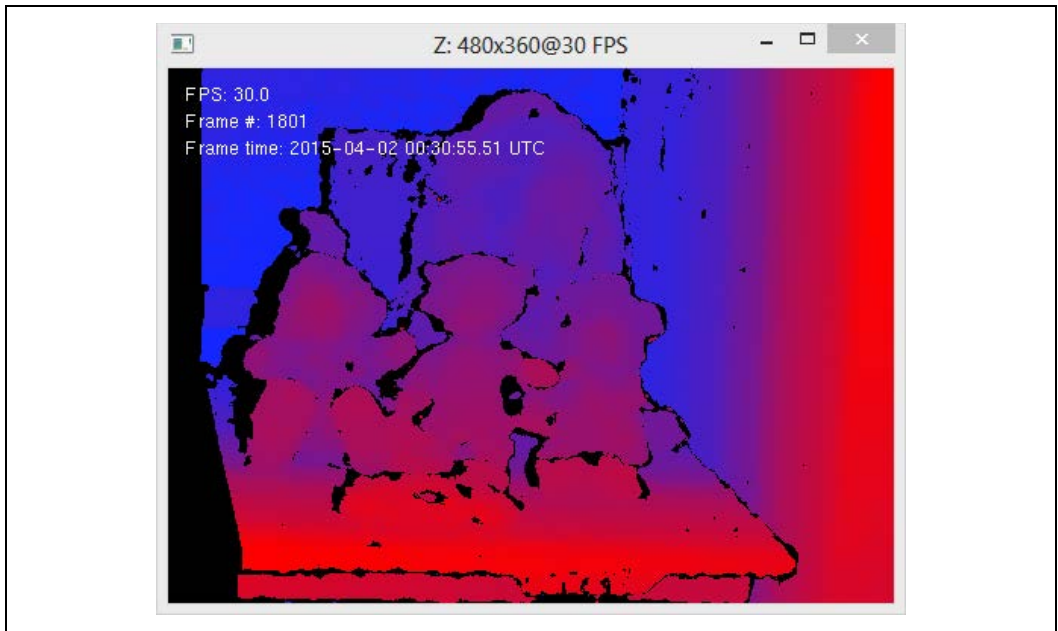

Figure 2-2. Example Depth Stream



The R200 3D camera is available in either a camera module or camera peripheral form factor option.

2.2 R200 Camera Module

The R200 module form factor option is the final product form factor for system integrators. This module should be integrated into a system chassis and connected directly to a motherboard that implements an Intel® RealSense™ 3D Camera Rear R200 compatible connector

Figure 2-3. R200 Module Form Factor

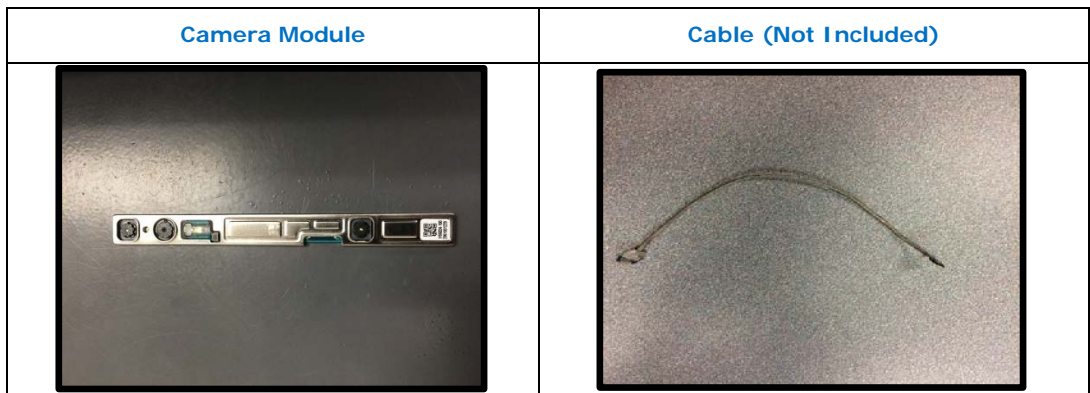

Note: Due to the variations in cable assemblies across system designs, a motherboard cable will not be provided with this form factor option. System integrators should work with their

respective cable suppliers to manufacture a cable according to the guidance provided in this document.

2.3 Components

Table 2-1. Component Descriptions

Acronym	Definition
AR	Anti-Reflective (Coating)
ASIC	Application Specific Integrated Circuit
Baseline	Distance between Left and Right Infrared Imager
CMC	Common Mode Choke
EMI	Electromagnetic Interference
ESD	Electrostatic Discharge
FEA	Finite Element Analysis, a type of mechanical simulation
FHD	Full High Definition
FOP	Field of Projection (Horizontal/Vertical/Diagonal)
FOV	Field of View (Horizontal/Vertical/Diagonal)
GPIO	General Purpose Input/Output
IR	Infrared
LED	Light Emitting Diode
PCB	Printed Circuit Board
R200	Intel® RealSense™ R200
RFI	Radio Frequency Interference
TBD	To Be Determined
TDP	Thermal Design Power
TIM	Thermal Interface Material
TJ	Component Junction Temperature
USB	Universal Serial Bus

Figure 2-4. Component Locations (Front View)

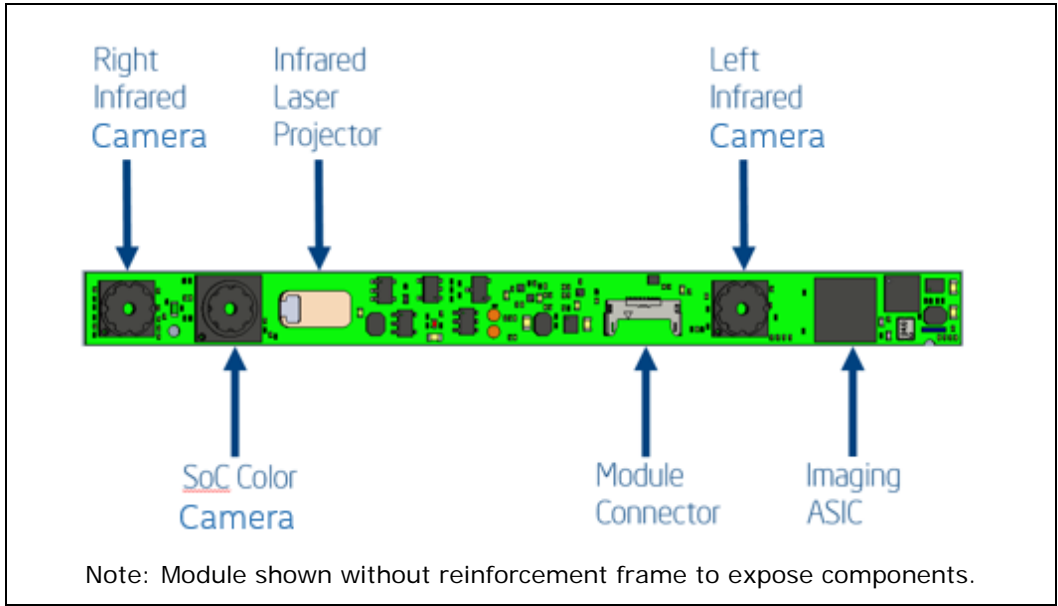

2.4 Storage and Operating Conditions

Table 2-2. Storage and Operating Conditions

Condition	Description	Min	Max	Unit
Storage (Still Air), Not Operating	Temperature (Sustained, Controlled) ⁽¹⁾	0	40	°C
	Temperature (Short Exposure) ⁽²⁾	-40	70	°C
	Humidity, Non-Condensing	90% RH, 30°C		
Operating ⁽³⁾ (Still Air)	Temperature	0	50	°C

NOTES:

1. Controlled conditions should be used for long term storage of product.
2. Short exposure represents temporary max limits acceptable for transportation conditions.
3. Component case temperature limits must be met for all operating temperatures, module performance will degrade at higher temperatures.

2.5 Handling Conditions

The R200 has limited ESD protection built into the subassembly.

Table 2-3. Electrostatic Discharge Caution

	<p>To provide a consistent ESD protection level during R200 system assembly and rework, it is recommended that the JEDEC JESD625-A requirements standard be incorporated into the ESD environment controls.</p>
---	---

§ §

3 Component Specification

3.1 Imaging

3.1.1 Color Imaging System

The color camera on the R200 camera module provides texture information. Usages for the texture information include overlay on a depth image to create a color point cloud and overlay on a 3d model for reconstruction.

Table 3-1. Color Camera Properties

Parameter	R200 Color Camera
Active Pixels	1920x1080
Sensor Aspect Ratio	16:9
Filter Type	IR Cut Filter
Focus	Fixed
Shutter Type	Rolling Shutter
Vertical Field of View	43° +/-2°
Horizontal Field of View	70° +/-2°
Diagonal Field of View	77° +/-4°

3.1.2 Infrared Imaging System

The module has two infrared cameras, they are identical parts and are configured with identical settings. The imagers are labeled “left” and “right” from the perspective of the camera module as shown in [Figure 4-1](#).

Table 3-2. Infrared Camera Properties

Parameter	Infrared Cameras
Active Pixels	640x480
Sensor Aspect Ratio	4:3
Filter Type	IR Band Pass
Focus	Fixed
Shutter Type	Global Shutter
Vertical Field of View	46° +/-5°
Horizontal Field of View	59° +/-5°

Parameter	Infrared Cameras
Diagonal Field of View	70° +/- 4.5°

3.2 Infrared Light Projection

The infrared projector improves the ability of the stereo imaging system to determine depth by projecting a static infrared pattern on the scene to increase texture on low texture scenes. The projector contains a laser diode. The module is rated at class 1 level in normal operation. Do not modify or adjust the infrared projector or related circuitry. The laser diode can reach harmful 3B levels when exposed.

Figure 3-1. Infrared Projector

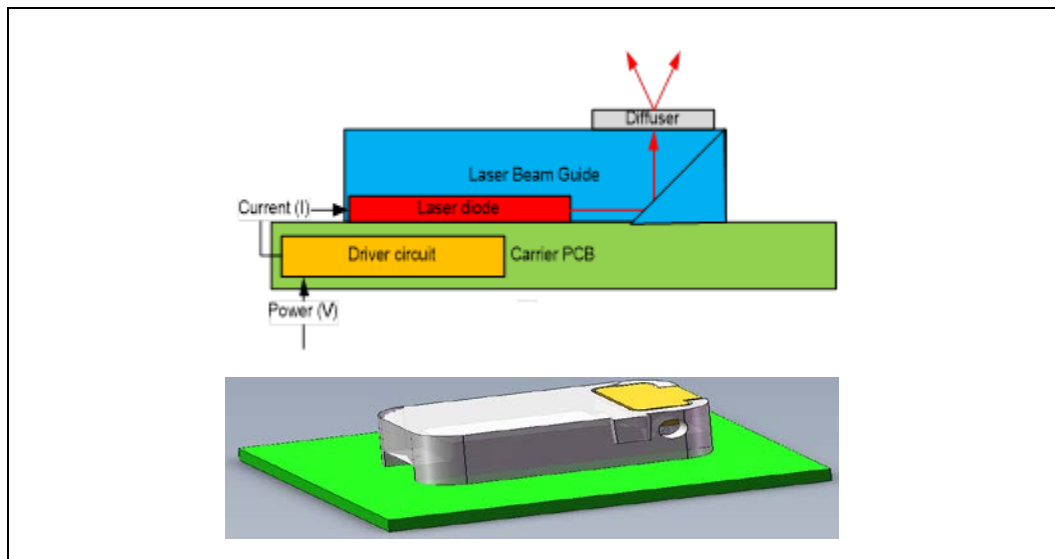

Table 3-3. Infrared Projector Parameters

Parameter	Laser Projector
Projector	Static Infrared Pattern
Illuminating Component	Infrared Laser Diode
Laser Wavelength	859nm Nominal
R200 Laser Compliance	Class 1, IEC 60825-1:2007 Edition 2
Vertical Field of Projection	60° +/- 5°
Horizontal Field of Projection	60° +/- 5°
Diagonal Field of Projection	80° +/- 5°

3.3 Activity LED

The camera module integrates one activity LED to notify the user if either the infrared camera or color camera is streaming data.

3.4 Temperature Sensor

The module is equipped with a thermal sensor that is used for laser safety. The software library provides access to the thermal sensor but it is not intended to be used by applications outside of development environments.

3.5 Camera Module Connector

The connector on the R200 camera module transmits the depth and color information to the host system. It also provides power delivery to the module and a way to update the module firmware. The data transfers are done over USB3.0 protocol. For more information on the host platform requirements please see the platform design guide chapter on depth camera module integration.

The receptacle mechanical drawing can be found as part of the thermal mechanical design package.



The receptacle is designed for 10 insertion and removal cycles, additional cycling may cause electrical or mechanical failures

Table 3-4. Module Receptacle Pinout

Pin	Signal	Function	Description
1	GND	Power Delivery	Ground
2	USB3_SSTX-	USB3.0 Data	SuperSpeed TX Differential Pair Negative
3	USB3_SSTX+	USB3.0 Data	SuperSpeed TX Differential Pair Positive
4	GND	Power Delivery	Ground
5	USB3_SSRX-	USB3.0 Data	SuperSpeed RX Differential Pair Negative
6	USB3_SSRX+	USB3.0 Data	SuperSpeed RX Differential Pair Positive
7	GND	Power Delivery	Ground
8	RSVD	Reserved	Reserved (No Connect)
9	3.3VDC	Power Delivery	3.3V Image System Power
10	3.3VDC	Power Delivery	3.3V Image System Power

3.6 Other Components

The image system consists of additional components that interface directly to the R200 ASIC. These components are described in table below.

Table 3-5. Camera Module Functional Components

Feature	Requirement
Laser Driver	The camera module implements a laser driver which controls the infrared laser within the infrared laser projector system.
Laser Thermal Control	The camera module implements a laser safety control circuit that adjusts laser drive output based on operating conditions.
Flash Memory	The camera module implements flash memory for storing the module component firmware and module calibration data.
1.8V Voltage Regulator	The camera module implements a DC to DC voltage converter to generate 1.8 V from the 2.5 V supply.
2.8V Voltage Regulators	The camera module implements 2 DC to DC voltage converters to generate 2.8 V from the 3.3 V supply.
2.5V Voltage Regulator	The camera module implements a DC to DC voltage converter to generate 2.5 V from the 3.3 V supply.
1.1V Voltage Regulator	The camera module implements a DC to DC voltage converter to generate 1.1 V from the 3.3 V supply.
Oscillator	The camera module implements a 24 MHz crystal which supplies the reference clock source to the image system.

§ §

4 Functional Specification

4.1 Embedded 3D Imaging System

The R200 module uses stereo vision to calculate depth. The stereo vision implementation consists of left infrared camera, right infrared camera, and an infrared laser projector. The left and right camera data is sent to the R200 ASIC. The ASIC calculates depth values for each pixel in the image. The infrared projector is used to enhance the ability of the system to calculate depth in scenes with low amounts of texture. Traditionally, scenes with low texture such as walls presented a challenge for stereo vision systems to calculate depth.

Figure 4-1. Active Stereo Technology Overview

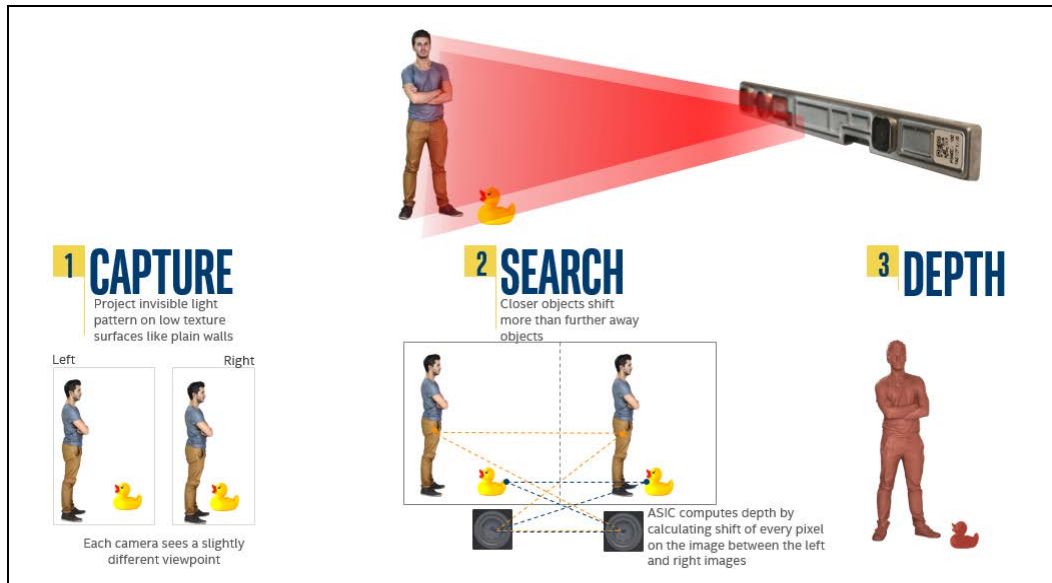

4.2 Camera Video Stream Formats

Table 4-1. Supported Left/Right Infrared Camera Video Stream Formats and Modes

Format	Description	Resolution	Frame Rates
RY12LY12_4_3	12 bits right, 12 bits left, 4 pixels packed into 3 32 bit words	640x480, 492x372, 332x252	30, 60
LY_8_4_1	8 bits left, 4 pixels packed into 1 32 bit words	640x480, 492x372, 332x252	30, 60

Format	Description	Resolution	Frame Rates
LY12_2_1	12 bits left, 2 pixels packed into 1 32 bit words	640x480, 492x372, 332x252	30, 60
RY8LY8_2_1	8 bits right, 8 bits left, 2 pixels packed into 1 32 bit words	640x480, 492x372, 332x252	30, 60

Table 4-2. Supported Color Camera Video Stream Formats and Modes

Format	Description	Resolution	Frame Rates
Raw10	Bayer image pattern	1920x1080	30
YUY2		1920x1080	30
YUY2		640x480	15,30,60

Table 4-3. Supported Depth Video Stream Formats and Modes

Format	Description	Resolution	Frame Rates
Z16_2_1	16 bits, 2 pixels packed into 1 32 bit word	628x468, 480x360, 320x240	30, 60

Note: The modes listed above are hardware supported modes and may not be visible to applications.



All frame rates are expressed as nominal. Effective frame rates can vary depending on the exposure settings of the camera. Camera settings that increase the exposure time can decrease the effective frame rate.

§ §

5 Firmware

5.1 Firmware Update (Windows* Only)

During a firmware update, a firmware update application is used to load new firmware into the R200 memory. The R200 firmware will check the firmware manifest and digitally sign the updated firmware. If the firmware update is interrupted or becomes corrupted the new code will not be signed and the device will revert to recovery firmware after restart. Recovery firmware is intended for the device to accept a new firmware update and should not be used for normal operation.



The firmware version programmed by the firmware utility is tightly coupled with the DCM runtime version. This is why the firmware utility is bundled with the DCM system software installer and should not be decoupled. If there is a mismatch between firmware and DCM versions, features can cease to function or unknown behaviors can occur.

5.2 Infrared Camera Functions

Table 5-1. Left and Right IR Sensor Configuration

Property	Min	Max	Default	Auto
Image Gain	1	63.9	-	Yes
Image Exposure	0.1	33.3	-	Yes



The left and right IR sensors must share settings, it is not possible to configure each IR sensor individually

5.3 Color Camera Functions R200

Table 5-2. RGB Sensor Configuration

Property	Min	Max	Default	Auto
Image Gain	1	63.9	-	Yes
Image Exposure	0.1	33.3	-	Yes
Brightness	0	255	55	No
Contrast	16	64	32	No

Property	Min	Max	Default	Auto
Saturation	0	255	128	No
Hue	-2200	2200	0	No
Gamma	100	280	220	No
White Balance	2000	8000	-	Yes
Sharpness	0	7	0	No
Backlight Comp	0	4	1	No
PowerLine Freq	50	60	60	No

§ §

6 System Interoperability

6.1 USB Composite Device

The R200 ASIC is a USB3 composite device which exposes all hardware endpoints to the operating system. The ASIC is a bulk device and transmits depth and color videos streams in data bursts rather than as constant video streams.

The camera module is compliant with the USB3.0 specification. The module does not support USB2.0 connections and does not route the USB2.0 pins. In the case of a USB3.0 link training failure it is possible that the module will not be detected. Because the module is an integrated device, it is not expected for the module to encounter USB3.0 link training failures.

Intel® RealSense™ 3D Camera (R200), has passed the USB-IF Test Procedure for SuperSpeed products, and is posted on the USB-IF Integrators List.

Product Name: Intel® RealSense™ 3D Camera/ R200

Product Test ID: 310000173

Figure 6-1. USB Composite Device Hardware ID

Hardware ID	Bits	Value
Vendor ID	[15:0]	0x8086
Device ID	[15:0]	0x0A80
Revision ID	[15:12]	Firmware Major Version
	[11:5]	Firmware Minor Version
	[4:0]	Firmware Sub-Minor Version

6.1.1 Device Endpoints

Table 6-1. USB Composite Device Endpoints

Endpoint
USB Composite Device
Intel® RealSense™ 3D Camera (R200) RGB
Intel® RealSense™ 3D Camera (R200) Depth
Intel® RealSense™ 3D Camera (R200) Left-Right

6.2 Power States

The R200 device power state is dependent on the video stream configuration and system state.

Table 6-2. Device Power States

System State	Device State	Link State	Device Power	Streaming
S0	D ₀	U ₀	V _{CC} = ON	Yes
S0	D _{3Cold}	U ₃	V _{CC} = OFF	No
S3/S4/S5	D _{3Cold}	U ₃	V _{CC} = OFF	No
Connected Standby ⁽¹⁾	D _{3Cold}	U ₃	V _{CC} = OFF	No
⁽¹⁾ Connected Standby and Modern Standby are an operating specific state and only applies to systems that have support.				



The R200 is not a wake device. If the R200 is put into D₃ then it is up to the client system to wake. If the host system does not remove power from the R200 in D₃ the module will continue to consume power while idle which is not recommended.

6.2.1 Power Consumption

Table 6-3. Typical Power Consumption

Depth Mode	Infrared Mode	Color Mode	Power	Unit
OFF	OFF	OFF	0.334	W
OFF	OFF	1080P, 30FPS	0.75-.92	W
VGA, 60FPS	VGA, 60FPS	OFF	0.99-1.15	W
VGA, 60FPS	VGA, 60FPS	1080P, 30FPS	1.3-1.6	W

§ §

7 System Integration

7.1 Integration Overview

The small size of the R200 module provides system integrators flexibility to design into a wide range of products. This section describes how to integrate the module into a system chassis.

7.2 Module Stability

It is critical that the R200 module does not experience flex during system integration or during use after integration. The module arrives calibrated and ready for installation into a system. Micron level flexing of the module can render the calibration incorrect and will result in poor performance or nonfunctional depth data. It is important for system designers to isolate the module from any chassis flex the system may encounter. **Micron levels of module flex can disrupt the depth stream.** While the module has reinforcement housing, the housing is not intended to counter loads from chassis flex. The primary function of the housing is to prevent loss of calibration from handling and operating environments.

There are three types of flex the module can encounter independently or in combination: Y, Z, and twisting. The impacts to performance of each flex type are discussed in this section.

Flex across the module Z axis shown in figure below, will cause error in the depth image as it modifies the baseline between the imagers. Extreme flex in this direction will cause a loss of depth data.

Figure 7-1. Z Direction Module Flex Example

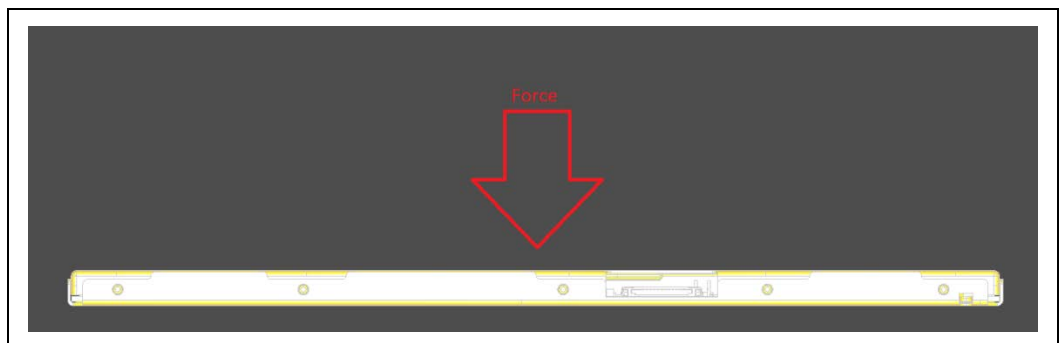

Flex across the module Y axis shown in figure below, will cause a loss of depth data. The module is most resilient to flex across this axis to prevent loss of depth data.

Figure 7-2. Y Direction Module Flex Example

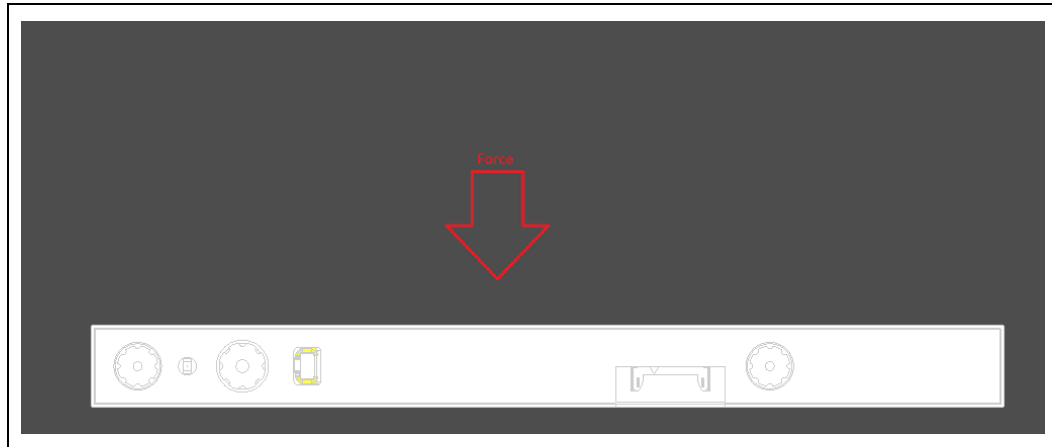

Twisting forces are composite forces that rotate the module on the X axis shown in figure below. This type of movement creates displacement in both the X and Z directions. The chassis design should avoid transmitting twisting forces to the module as much as possible.

Figure 7-3. Twist Module Flex Example

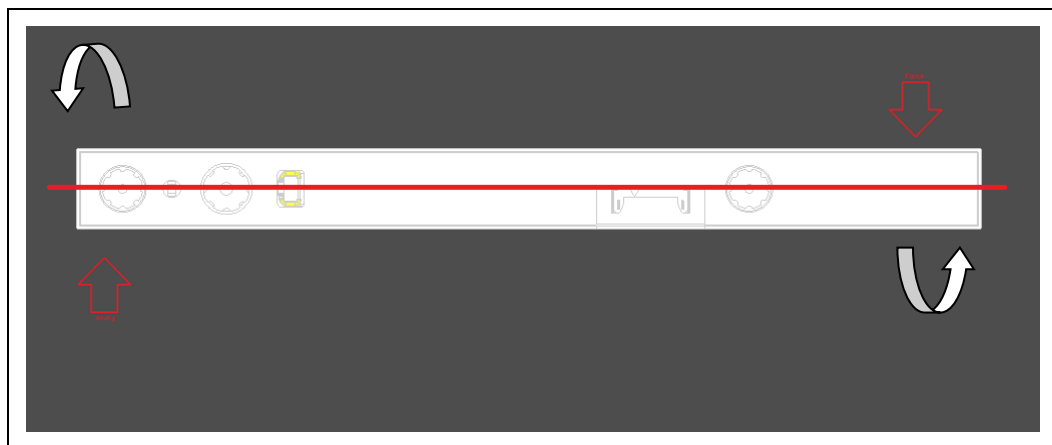

7.2.1.1 Module Flex Specifications

Module flex specifications are provided for in the z-direction and for twist about the module's x-axis as demonstrated in the figure above. The specifications are separated into a number of different regions:

1. Depth performance degradation is minimal and the module can continue to operate under its current levels of deflection without a significant impact to depth data.
2. Depth performance degradation is significant. However, when the load or deflection is removed from the module, the module depth performance will return to proper levels without requiring user calibration.

- Depth performance degradation is significant. When the load or deflection is removed from the module a user calibration will be required to recover the module's depth performance.

Note: These are Intel® RealSense™ R200 module specifications. Further analysis is required to determine the relationship between the system flex and the module flex, and as a result, determine size of the air gap around the module in order to buffer the module from the system.

Table 7-1. Module Bend and Twist Limits

Limit	Max Load	Deflection
Bend while functional	5 N	0 - 40 um
Bend Nonfunctional	129 N	40um - 1mm
Bend Failure (Recalibration Required)	193 N	1 - 1.5mm
Twist while functional	2.4Nmm	0.5 degrees
Twist Nonfunctional	48Nmm	0.5-1.5 degrees
Twist Failure (Recalibration Required)	96Nmm	1.5-2.0 degrees

7.3 Camera Module Dimensions

The camera module nominal dimensions, with tolerances, are in the mechanical design package.

7.4 Camera Module Mass

The module mass is approximately 8 grams.

7.5 Grounding

Testing should be performed to quantify the level of grounding required. It is recommended that there be at least two ground contact points to the system.

- The thermal heat spreader and reinforcement frame can be used as primary GND contact points to the system.
- The openings at the system for each of the R200 components should be as small as possible.

7.6 Motherboard Receptacle

It is recommended that the motherboard receptacle is grounded as well as ground bar pads implemented.

Figure 7-4. Receptacle Ground Bar Motherboard Connections

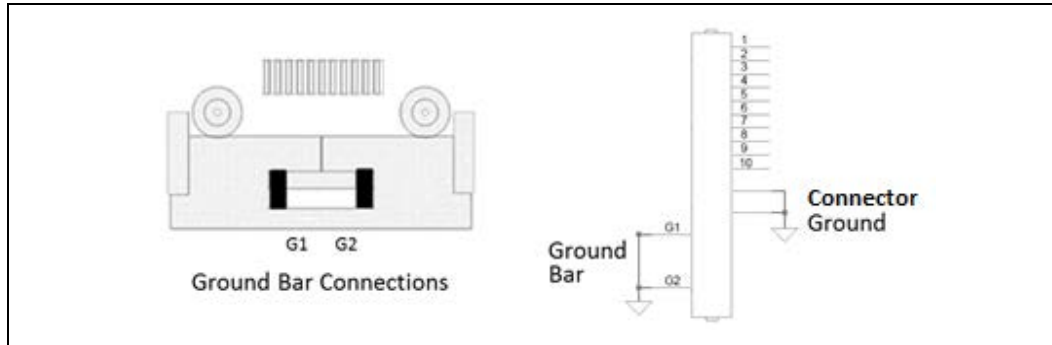

7.7 Shielding

Testing should be done to quantify the level of shielding required. Typically, if the R200 is placed greater than 2-3" from system antennas, only the cable may require shielding.

- The cable should be wrapped end to end with a conductive EMI fabric. The fabric should make contact with the connector plug shield on each end.
- The conductive fabric should make a ground connection with the system chassis.
- Between the cable shielding and the module shielding, the opening should be as small as possible to avoid RFI leakage.
- Component placement and cable routing must be optimized to minimize noise pickup from system sources.
- The RFI value should not increase more than 5dB when the R200 is active compared to when inactive.



Conductive shielding material must not make contact with any non-GND subassembly components, pads, or signals.

7.8 Rear Cover Design Guidance

In addition to any thermal heat spreaders, the rear cover design must take into consideration the openings for the R200 camera, projector, and LED. The openings should be designed so that they provide protection from dirt and damage but also accommodate the following considerations.

- Maximize effective field of view of the cameras and field of projection of the projector
- Minimize air gap distance between the bezel surface and the front of the imaging module components. This is done to minimize the size of the holes in the rear cover required.
- Employ gasket material and separate cover material windows to isolate the IR laser projector output and prevent reflections off the cover material back into the system chassis.

The R200 computer aided design model (part of mechanical design package) includes the lens field of view projection profiles for each component. It is recommended to use the model along with a platform chassis model to minimize the cover hole diameters.

7.8.1 Transparent Cover Material

It is recommended to use a transparent cover material over in the rear cover holes to protect the camera module and prevent dirt from entering the system chassis. For the IR projector and IR cameras, the material must have a 98% or higher transmission rate in the 854 nm to 864 nm range. Anti-reflective coatings can help increase the IR transmission of transparent material. Most designs will require an AR coating on both sides of the cover material to reach 98% IR light transmission, using material with lower than 98% transmission can result in poor depth performance. Because the camera performance is limited by IR light from the projector indoors, a transparent cover material that reduces IR light transmission will decrease the working range of the camera.

Figure 7-5. Example IR Transmission of Acceptable Cover Material

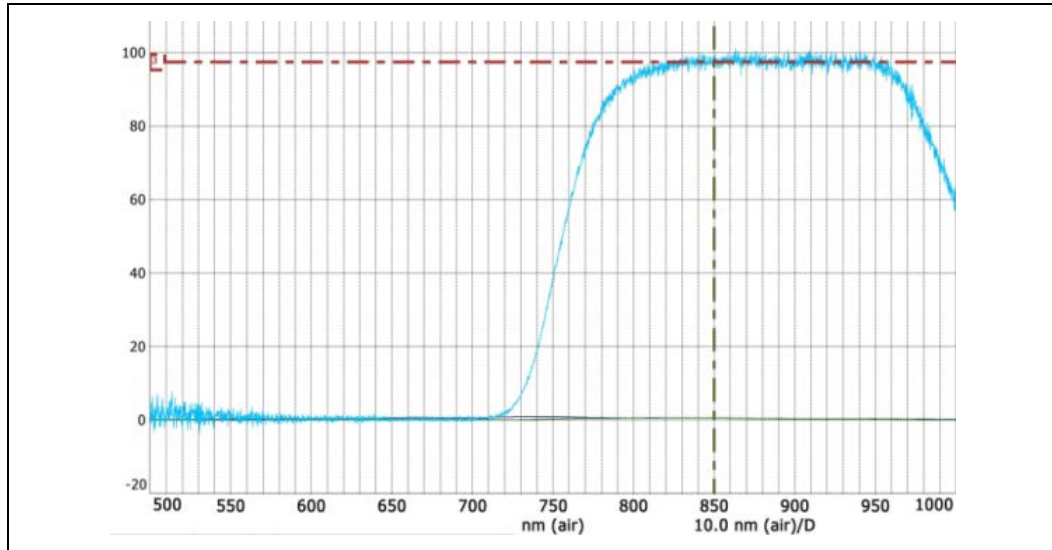

7.8.2 Gaskets

Gaskets are recommended for providing optical isolation and dust protection. However, gaskets can impede FOV and place unwanted stress on the module or the individual sensor lens holders.

Gasket static force can deform the cosmetic baffle/lens holder resulting in poor image quality and permanent damage to the camera. Gaskets placed on the R200 housing can transfer chassis flex into the camera module causing loss of depth data. Gasket thickness has a large effect on the static force applied to the module surface. The thinner the seal, the greater the static force applied. Once the gasket is compressed, the static force will increase exponentially.

7.8.3 Optical Isolation

Note: It is recommended to isolate the module cameras and IR projector from each other. Not properly isolating the cameras can result in leakage light as shown in Figure 7-6.

To light leakage, it is recommended to use a gasket material in between the rear cover holes and the module as shown in Figure 7-7. The gasket material needs to be compliant so that it does not transmit chassis flex forces to the module.

In addition, light can transmit through a single piece of cover material. Using separate cover material pieces with physical partitions for each opening minimizes the ability of light to transmit through the cover. Refer Figure 7-8 for reference.

Figure 7-6. Example of Light Leakage Effects



Figure 7-7. Example of Gasket Material Placement

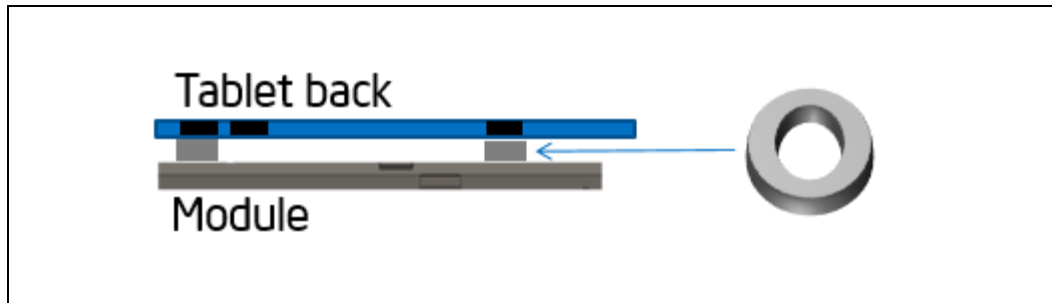

Figure 7-8. Example of Separated Windows for Cover Material



7.8.4 Dust Protection

Dust particles can accumulate over the camera lenses which can be visually unappealing and degrade image quality.

7.9 Thermal Design Guidance

While necessary to avoid module flex, the air gap around the module creates thermal challenges. Without thermal management, cameras on the module can be permanently damaged. Most system designs do not have sufficient free space to allow for air convection based cooling methods. This section lists a number of strategies that can be used to successfully meet module and system thermal requirements.

It is strongly recommended to use thermal modeling to simulate a chassis design before implementation. Any simulations should be correlated with empirical measurements to verify the simulated behavior is accurate.

In general it is recommended to place the camera module, SoC, and display driver as far apart as possible to minimize the thermal dissipation solution as shown in [Figure 7-9](#).

Figure 7-9. System Component Placement

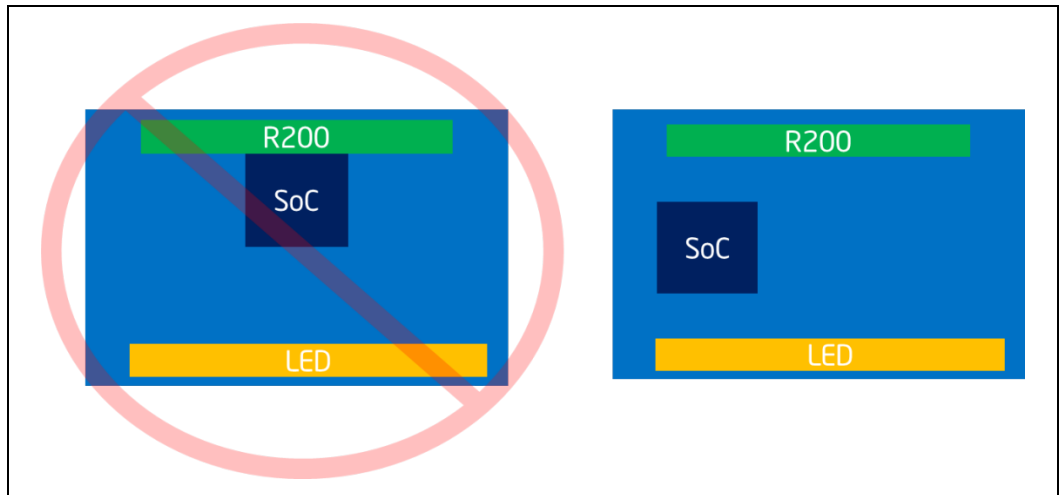

7.9.1 Thermal Limits

Table 7-2. Component Case Temperature Limits

Component	Case Temperature Limit	ΔT Junction to Case	Junction Temperature (Est.)
R200 Color Camera Sensor	61°C	9°C	70°C
IR Camera Sensor	62°C	8°C	70°C
Laser Projector	†	-	75°C
R200 ASIC	95°C	-	-

NOTE: † Laser projector temperature should be monitored through the R200’s embedded thermal sensor. Refer to the following section for more details.

It is not possible to directly measure junction temperature of the module components. Because of this, Intel recommends taking measurements with thermal probes at the locations identified in Figure 7-10. The measurements can be correlated with the thermal model to estimate component junction temperatures.

Figure 7-10. Module Thermal Probe Points

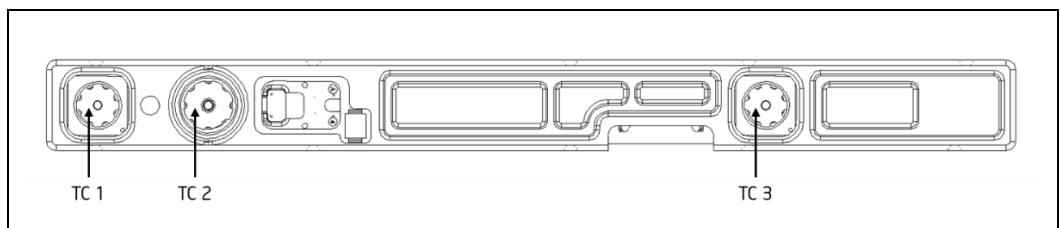

Table 7-3. Component Case Temperature vs. Junction Temperature

Point	Component	Junction Temp (Est.)
TC1	Right IR Camera Surface	Case Temp +8°C
TC2	RGB Camera Surface	Case Temp +9°C
TC3	Left IR Camera Surface	Case Temp +8°C

There is a single embedded thermal sensor on the R200 module. This thermal sensor has been correlated to the Laser Projector’s junction temperature. It should not be used to correlate junction temperatures of any of the other components on the R200 module.

Table 7-4. Thermal Sensor vs. Laser Projector Junction Temperature

Item	Component	Junction Temp (Est.)
Embedded Thermal Sensor	Laser Projector	Thermal Sensor +9 ± 3°C

7.9.2 Thermal Management

The recommended strategy for thermal management is to use thin copper foil to transfer heat away from the module. The use of flexible foil maintains the isolation of the module from the system chassis as the foil will not apply mechanical loading on the module. The copper foil is adhered to the back side of the module and transfers heat to a graphite heat spreader on the system chassis rear cover or over the LCD panel heat spreader. If the LCD panel heat spreader is used, care must be taken to avoid overheating the LCD panel.

It is recommended to mount the module on a thermally conductive chassis component. The thermal properties of the adhesive should be considered when choosing an adhesive to attach the camera module to the chassis. The bracket should contact metal in the chassis to dissipate heat and provide an ESD ground path. Alternatively, the copper foil can provide an ESD ground path and other non-electrically conductive adhesives can be used. While a longer bracket would help thermal performance, the bracket should be no more than 25mm long to keep the module isolated from chassis flex.

Figure 7-11. Module Thermal Solution Chassis or Frame Mount

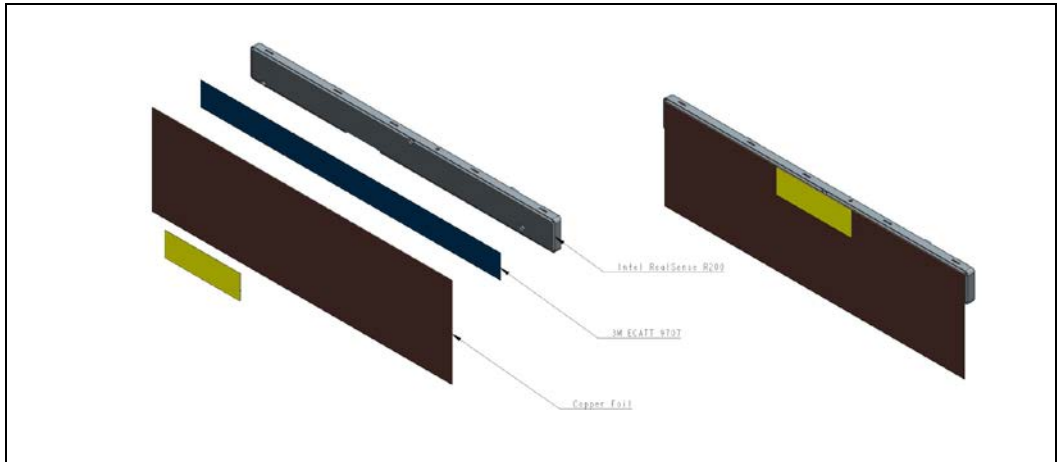

Figure 7-12. Module Mounting Chassis or Frame

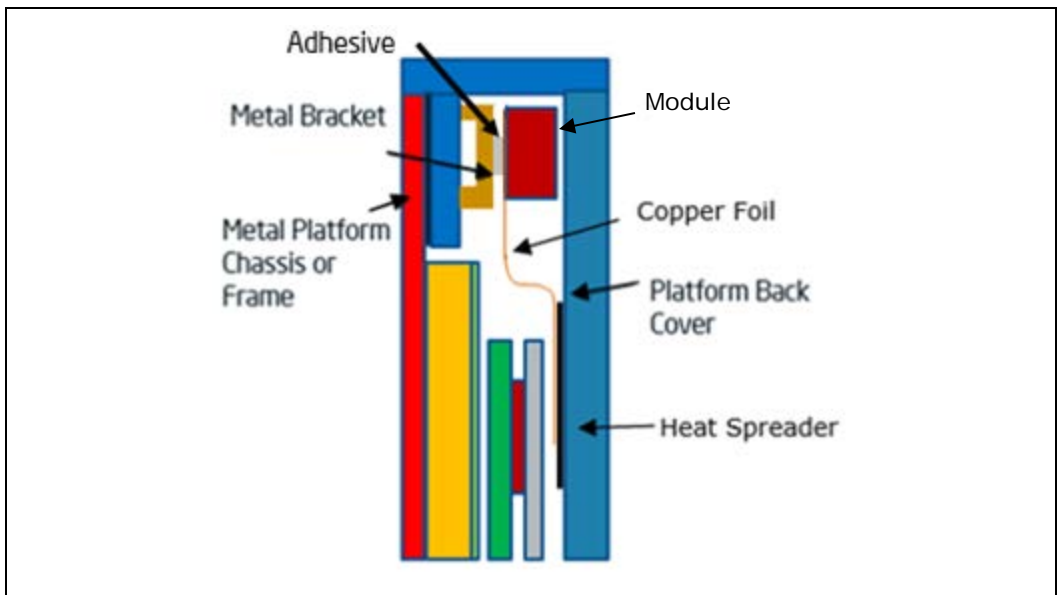

Figure 7-13. Module Thermal Solution Rear Cover Mount

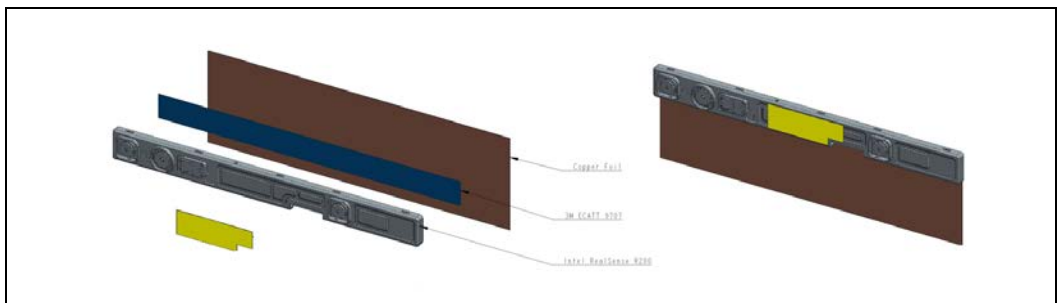

Figure 7-14. Module Mounting Rear Cover

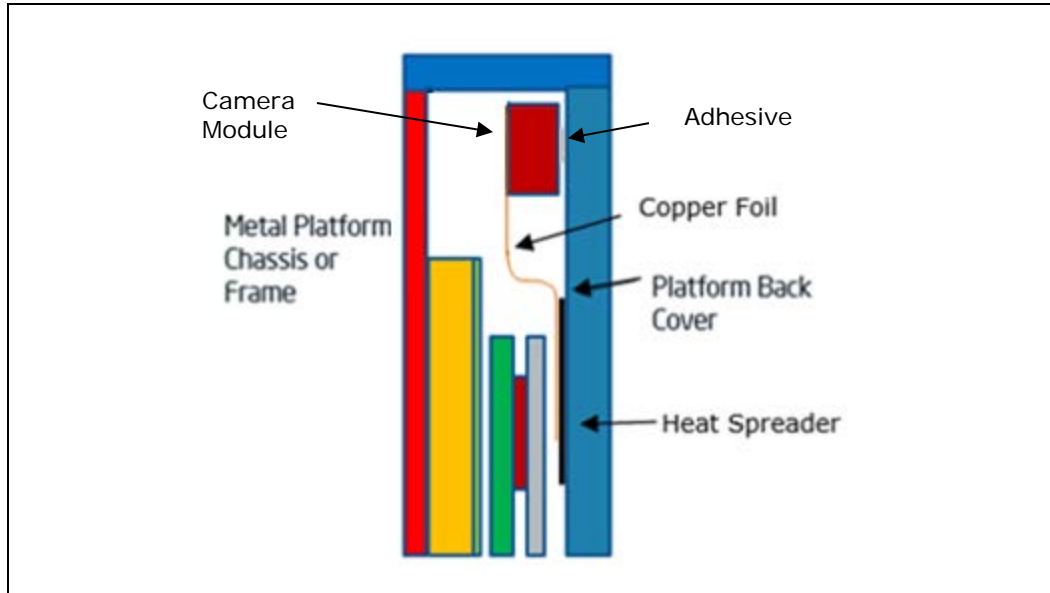

Table 7-5. Copper Foil Recommendation

Detail	Notes
Material	Copper
Thickness	0.2mm
Width	110mm (entire back side of module)
Min Overlap with Module	9.5mm

Table 7-6. Heat Spreader Recommendation

Detail	Notes
Material	Graphite
Thickness	0.2mm
Minimum Surface Area	260x80mm ²
Min Overlap With Copper Foil	10mm

7.10 Motherboard Routing Considerations

The imaging module requires a dedicated XHCI USB3 port. A USB hub must not be implemented between the imaging module and XHCI USB3 port to ensure highest possible bandwidth. The routing topology is specific to the platform. If the platform the R200 is being integrated is not listed below, please contact your Intel representative for support details.

7.10.1 Cable TX to RX Crossover

Standard USB3.0 requires the cable to cross the host TX to the device RX and the host RX to the device TX. For the R200 module, it is recommended not to cross over the signals in the cable to allow cable wiring to be flat and as thin as possible. The modules do not cross over the TX and RX signals, it is necessary to do this on the platform motherboard.

Figure 7-15. Example of Host Platform Motherboard Routing

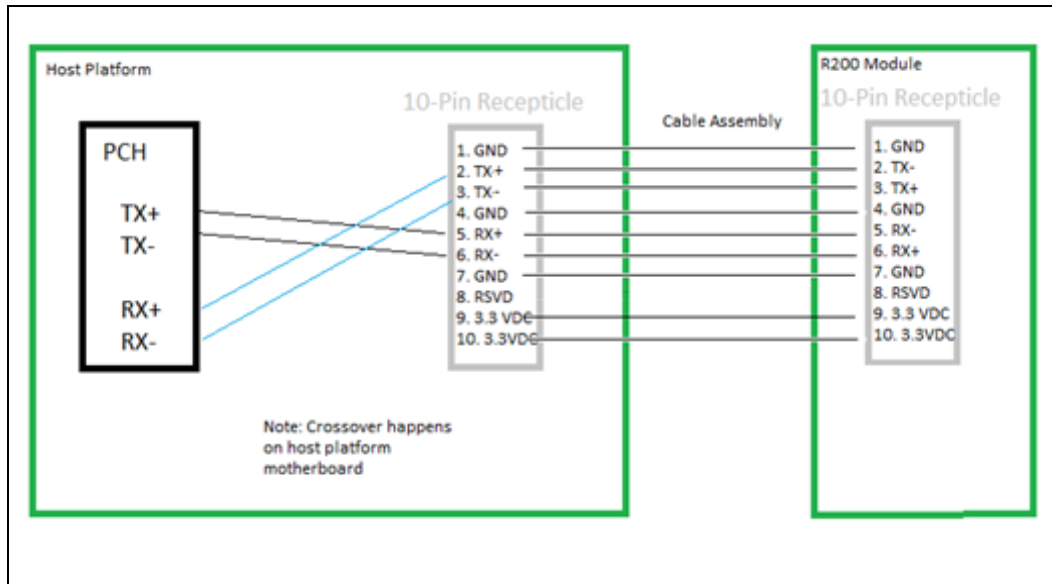

7.10.2 Power Gate Circuit

It is required that the host platform is able to gate power to the R200 module. The power gate must be controllable via an ACPI and BIOS controllable GPIO. It is recommended for the implementation to be able to vary the delay from when the GPIO is asserted to when the ACPI code notifies the OS the device is powered.

Figure 7-16. Module Platform Power Gate Example

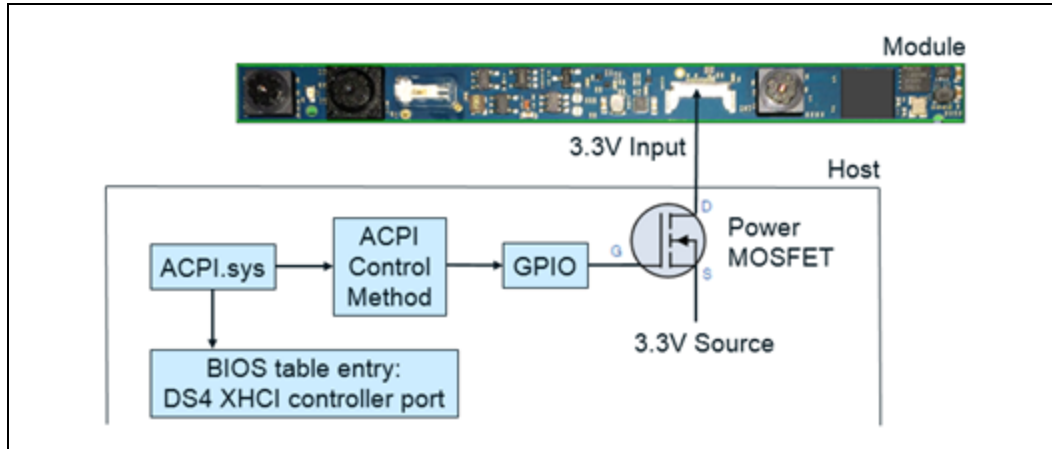

7.10.3 Platform Specific Routing Guidance

Contact local Intel representative for details on platform specific board routing requirements.

7.10.4 Motherboard Receptacle

Figure 7-17. System Receptacle Properties

Pin	Wire Description
Differential Impedance	75 to 105Ω (USB3 Signals)
Rise Time	50ps (20% - 80%)
Max Cross Talk	-34dB up to 2.5GHz.
Current Rating	0.3A ± 5%
Shielding	Metal shielding, connected to GND plane.
Grounding	Two ground bar connections in addition to the connector GND.

Table 7-7. Receptacle Pin Out

Position	Name	Type	Description
1	GND	-	Ground
2	USB3_SS _{TX-}	OUT	USB3 Transmitter Negative
3	USB3_SS _{TX+}	OUT	USB3 Transmitter Positive
4	GND	-	Ground
5	USB3_SS _{RX-}	IN	USB3 Receiver Negative
6	USB3_SS _{RX+}	IN	USB3 Receiver Positive
7	GND	-	Ground

Position	Name	Type	Description
8	RSVD	-	RSVD (No Connect)
9	V _{CC}	-	Supply Voltage, Connect to 3.3V
10	V _{CC}	-	Supply Voltage, Connect to 3.3V

Table 7-8. Receptacle Characteristics

Property	Description	Diagram
Shell Finish	Tin (Sn)	
Lock	Yes	
Ground Bar	Yes	
Alignment Boss	No	
Part Number	IPEX 20347-310E-12R	

7.10.5 High Speed Cable Assembly

The high speed cable assembly is developed and procured by the system integrator. The cable assembly design is specific to the system definition and must meet R200 cable assembly design specification.

Table 7-9. Plug Characteristics

Property	Description	Diagram
Shell Finish	Tin (Sn)	
Friction Lock	Yes	
Ground Bar	Yes	
Plug Part Number	IPEX 2047-0103R	
Housing Part Number	IPEX 20346-010T-31R	

Table 7-10. Cable Assembly Specification

Property	Description
Cable Length	508mm ± 10mm (~20 inches)
Controlled Impedance	50Ω ± 10%
Max Insertion Loss	7.0 dB at 2.5 GHz
Cable Shielding	Each plug should be connected to the receptacle shield and GND bar.
Minimum Gauge	40 AWG for micro-coax, 36 AWG for wire.



 Deviation from these properties is allowed, but the compatibility with the R200 receptacle must be maintained. Longer cable lengths is allowed, but signal integrity should be evaluated by the system integrator.

Table 7-11. Cable Assembly Interconnect Properties

Pos	R200	System	Gauge	Interconnect Description
1	GND	GND	40	50Ω micro-coax, shield soldered to GND bar.
2	USB3_SSTX-	USB3_SSTX-	40	50Ω micro-coax, shield soldered to GND bar.
3	USB3_SSTX+	USB3_SSTX+	40	50Ω micro-coax, shield soldered to GND bar.
4	GND	GND	40	50Ω micro-coax, shield soldered to GND bar.
5	USB3_SSRX-	USB3_SSRX-	40	50Ω micro-coax, shield soldered to GND bar.
6	USB3_SSRX+	USB3_SSRX+	40	50Ω micro-coax, shield soldered to GND bar.
7	GND	GND	36	UL 10064 Wire (Rated at least 0.3A.)
8	No Connect	No Connect	-	No Connect
9	V _{CC}	5V	36	UL 10064 Wire (Rated at least 0.3A.)
10	V _{CC}	5V	36	UL 10064 Wire (Rated at least 0.3A.)

 The TX to RX pair crossover is expected on the system board and not the cable assembly. This is done to allow for flat cable assemblies.

§ §

8 Calibration

The R200 camera module requires calibration if it is distorted during the assembly process or by environmental conditions in the field. For details on high volume calibration solutions, contact local Intel representative.

§§

9 System BIOS

The BIOS must map the integrated USB3 port to the R200 and report the location for each camera. The BIOS must declare the R200 power resource methods and creates an interface to directly control the power resource and interrupt pin through a GPIO.

9.1 UPC (USB Port Capabilities)

The USB3 port in the USB port allocation must be a non-companion port.

Table 9-1. UPC Elements

Element	Type	Description	Value
Port Is Connectable	Integer (BYTE)	Yes	0xFF
Port Connector Type	Integer (BYTE)	Fixed	0xFF
Reserved 0	Integer	N/A	0x00000000
Reserved 1	Integer	N/A	0x00000000

Figure 9-1. UPC Return Package Values

```

Name(_UPC, Package()) {
    0xFF,           // Port is Connectable and Internal
    0xFF,           // Connector is Proprietary and Fixed
    0x00000000,    // Reserved 0, must be zero
    0x00000000})  // Reserved 1, must be zero
}
    
```

9.2 PLD (Physical Device Location)

An independent _PLD table must be mapped to each camera's address. The address (_ADR) for the color camera (offset 0x0) and infrared camera (offset 0x2) are dependent on the USB port that the R200 is mapped.

For example, if the R200 was mapped to USB port 15 (0x0F), the color camera _ADR value is 0x0F and infrared camera _ADR value is 0x11. The UVC OS Address property can be used to verify this value.

Table 9-2. PLD Elements

Element	Bits	Description	Value
Revision	[6:0]	Current	2
Color	[7]	Ignore	1

Element	Bits	Description	Value
User Visible	[64]	Integrated	0
Panel Surface	[69:67]	Rear Surface	5
Vertical Position	[71:70]	Upper	0
Horizontal Position	[73:72]	Center	1
Group Position	[94:87]	Non-Companion USB3 Port	Unique Port Value
Rotation	[118:115]	Default Orientation, No Rotation	0
Vertical Offset	[143:128]	Offset from Panel Surface Origin	System Specific
Horizontal Offset	[159:144]	Offset from Panel Surface Origin	System Specific

Figure 9-2. PLD System Design Considerations

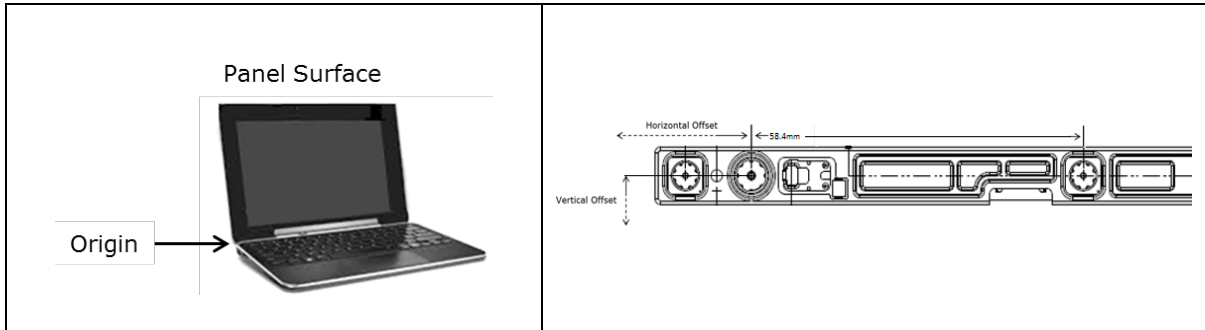

Table 9-3. PLD Return Package Values

Camera	Reference PLD Example ⁽¹⁾	Reference Attributes ⁽¹⁾
Depth	Name (PLD_DEPTH) { 0x82, 0x00, 0x00, 0x00, 0x00, 0x00, 0x00, 0x00, 0x24, 0x01, 0x80, 0x0F, 0x00, 0x00, 0x00, 0x00, VV, VV, HH, HH}	USB3 Port = 0xF (Group Position) ADR = 0xF + 0x2 = 0x11 V Offset = Y H Offset = X
Color	Name (PLD_COLOR) { 0x82, 0x00, 0x00, 0x00, 0x00, 0x00, 0x00, 0x00, 0x24, 0x01, 0x80, 0x0F, 0x00, 0x00, 0x00, 0x00, VV, VV, HH, HH}	USB3 Port = 0xF (Group Position) ADR = 0xF + 0x0 = 0xF V Offset = Y H Offset = X + 58.4

(1) The group position, vertical and horizontal offsets are system design specific and defined by the integrator. Apart from the 58.4 mm horizontal offset difference between the infrared left camera and color camera on the subassembly, the PLD for both cameras are identical.

10 Packaging and Labeling

The 8.0 x 6.0 mm camera module label illustrated in [Figure 10-1](#) consists of a 3.5 x 3.5 mm barcode and descriptor fields described in fields table.

Figure 10-1. Camera Module Label

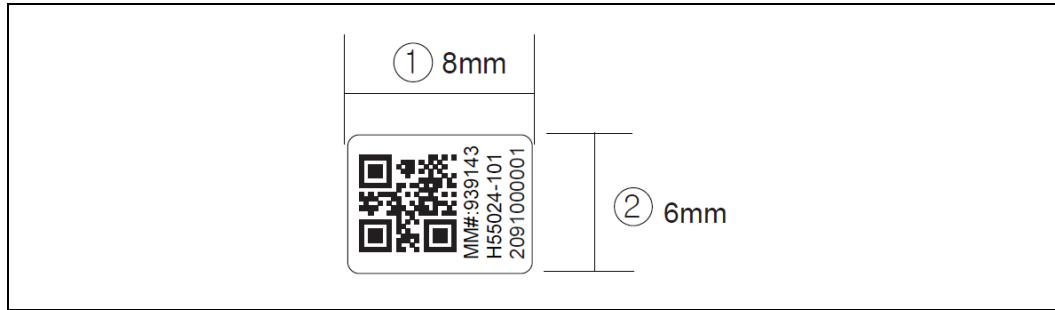

Note: The scan code is encoded with the serial number, YWWFXXXXXX

Table 10-1. Scan Code Fields

Group	Field Identifier	Description	Type
Serial Number	YWWFXXXXXX	Manufacture Date Factory Code Serial Code	Dynamic
Product Assembly Number	939143	Material Master Number	Static
	H55024-101	Product Identifier Code	Static

§ §

11 Regulatory Compliance R200

	System integrators should refer to their respective regulatory and compliance owner to finalize regulatory requirements for a specific geography.
---	---

This device complies with International Standard EN/IEC 60825-1:2007 edition 2 for a Class 1 laser product. This device also complies with US FDA performance standards for laser products except for deviations pursuant to Laser notice No. 50, dated June 24, 2007.

<p>CLASS 1 LASER PRODUCT CLASSIFIED EN/IEC 60825-1 2014 (EU & other) CLASSIFIED IEC 60825-1 2007 (US)</p>
<p>This device complies with US FDA performance standards for laser products except for deviations pursuant to Laser Notice No. 50 dated June 24, 2007.</p>

Caution--use of controls or adjustments or performance of procedures other than those specified herein may result in hazardous radiation exposure.

Manufactured by Intel Corporation
2200 Mission College Blvd., Santa Clara, CA 95054
Model Number: Rear R200

U.S. FDA accession number is **1420260-000** and the peripheral version is **1420260-001**.

This number should be entered into Box B.1 of the Food and Drug Administration (FDA) 2877 Declaration for Imported Electronic Products Subject to Radiation Control Standards.

The camera module certification is transferable to the system and no system recertification is required. However, the following statements and labels must be included in the user manual of the system product.

This product is classified as Class 1 under the IEC 60825-1 edition 2, 2007 in the US and is classified as Class 1 under the EN/IEC60825-1 edition 3, 2014 in the EU and other countries, at the time of publication. This device also complies with US FDA

performance standards for laser products except for deviations pursuant to Laser notice No. 50, dated June 24, 2007.

	<p>The image system continuously monitors the IR laser projector system. If the projector system falls outside normal operating conditions for Class 1, the IR laser projector system is turned off. This is a requirement for Class 1 laser devices.</p>
	<p>There are no service/maintenance, modification, or disassembly procedures for R200 and infrared projector. The system integrator must either notify Intel or return modules before any failure analysis is performed.</p>
	<ul style="list-style-type: none">• Do not attempt to open any portion of this laser product.• There are no user serviceable parts with this laser product.• Modification or service of the R200, specifically the infrared projector, may cause the emissions to exceed Class 1.

This device is EU RoHS 2 (Directive 2011/65/EU) compliant and low halogen (PCB). For additional details please download the [R200 Material Declaration Data Sheet](#).



www.ul.com/database

NWGQ2.E139761, NWGQ8.E139761

§ §

12 R200 Interconnect Cable Drawings

The interconnect cable can be used to connect the R200 to the motherboard receptacle or to the receptacle on the USB adapter card.

Table 12-1. Cable Part Numbers

Vendor	Part Number	Length	Revision	Sales Contact
Amphenol	H26311-001	100mm	AX1	Bruce Motavaf AGIS - Sales Engineer Amphenol bruce.motavaf@amphenol-gjs.com 408.799.6060
Amphenol	H26312-001	150mm	AX1	
Amphenol	H26313-001	300mm	AX1	
Amphenol	H26314-001	500mm	AX1	

Figure 12-1. Cable Mechanical Drawing

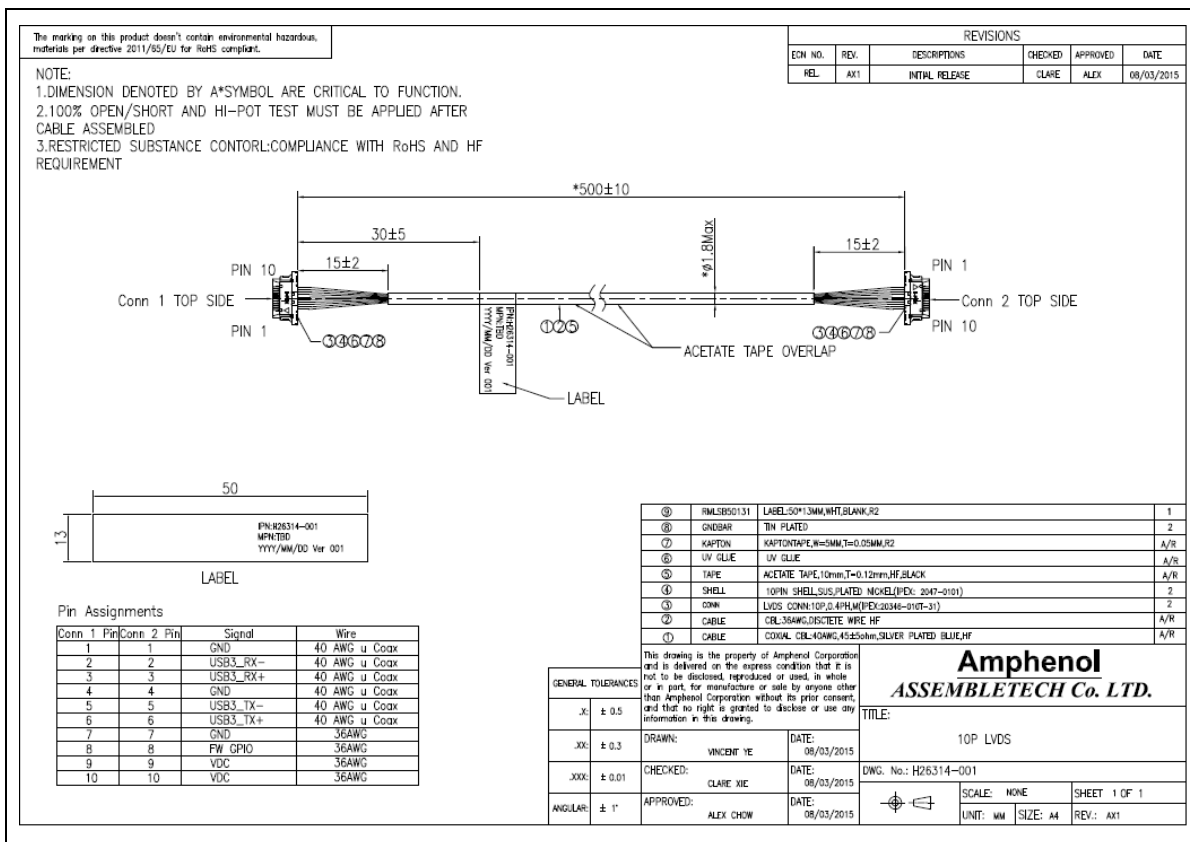

§ §

13 R200 Connector Drawings

Figure 13-1. R200 Receptacle Mechanical Drawing

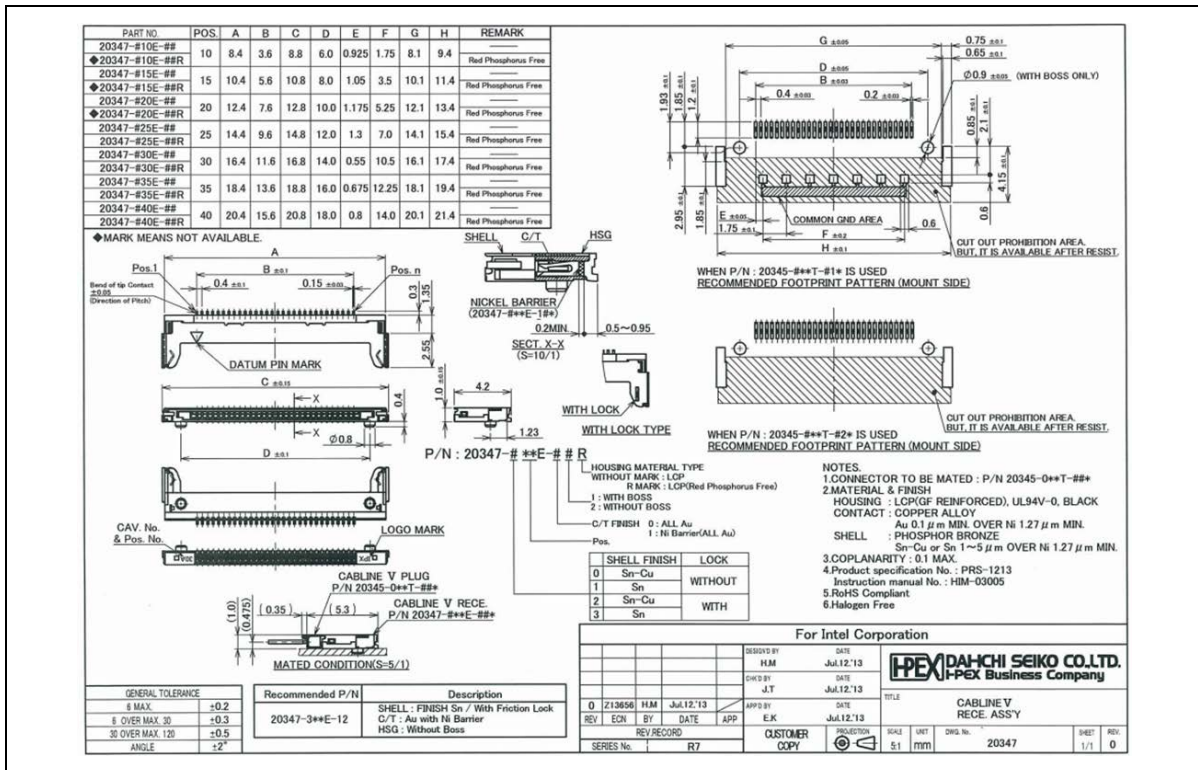
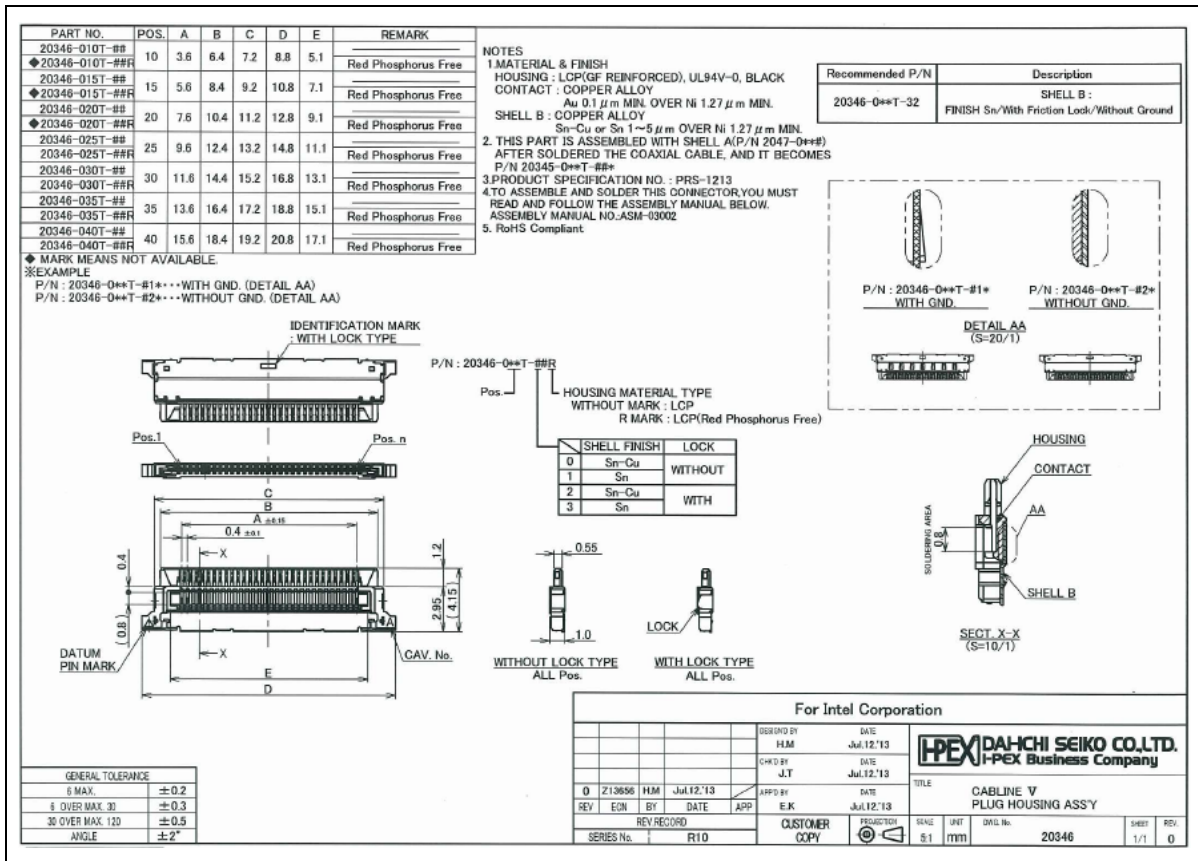

Figure 13-2. R200 Interconnect Plug Mechanical Drawing



SS

14 Schematic Checklist

The following checklist should be compared to the motherboard design.

Table 14-1. Motherboard Connector Signals

Connector	Motherboard	Required	√
Pin 1	Routed to GND	Y	
Pin 2	Routed to USB3_RXN	Y	
Pin 3	Routed to USB3_RXP	Y	
Pin 4	Routed to GND	Y	
Pin 5	Routed to USB3_TXN	Y	
Pin 6	Routed to USB3_TXP	Y	
Pin 7	Routed to GND	Y	
Pin 8	Not Connected	Y	
Pin 9	Routed to 5V Supply	Y	
Pin 10	Routed to 5V Supply	Y	
Connector	Routed to GND	Y	
Connector	Routed to GND	Y	
Ground Bar	Routed to GND	Y	
Ground Bar	Routed to GND	Y	

Table 14-2. USB_RX Motherboard Signals

Signal	Motherboard	Required	√
Pin 2	ESD protection diode connected to GND.	Optional	
Pin 3	ESD protection diode connected to GND.	Optional	

Table 14-3. USB_TX Motherboard Signals

Signal	Motherboard	Required	√
Pin 5	Inline 80 Ohm choke placed close to connector.	Y	
Pin 5	Inline 0.1uF AC capacitor placed close to the connector.	Y	
Pin 5	ESD protection diode connected to GND.	Optional	
Pin 6	Inline 80ohm choke placed closed to connector.	Y	
Pin 6	Inline 0.1uF AC capacitor placed close to the connector.	Y	
Pin 6	ESD protection diode connected to GND.	Optional	

Table 14-4. Power Signals

Signal	Motherboard	Required	✓
Pin 9/10	Series components rated for at least 1A.	Y	
Pin 9/10	Independent 3.3V controllable FET	Y	
Pin 9/10	Routed 3.3V FET control GPIO	Y	

§ §