

承认书

SPECIFICATION FOR APPROVAL

Switching power Supply 开关电源

客户:

CUSTOMER:

产品描述:

DESCRIPTION: 12VDC 5A Power supply

机种型号:

OUR MODEL NO: JYH32-1205000

样品编号: 日期:

SAMPLE NO: _____ DATE: 2016-02-16

产品颜色:

SAMPLE COLOR: Black White

APPROVAL SIGNATURE/客户确认		
核准/APPROVED BY	审核/CHECKED BY	检测/TESTED BY

Manufacturer/制造商		
业务/SALES	核准/APPROVED BY	设计/DESIGNED BY

版本目录/Rev. List			
版本/Rev.	日期/Date	描述/Description	制订/Design
A0	2014-04-11	新版本/New Rev.	Tony
A1	2016-02-16	V1.1	William

Table of contents

1、描述/DESCRIPTION.....	3
2、输入特性/INPUT CHARACTERISTICS.....	3
3、输出特性/OUTPUT CHARACTERISTICS.....	4-5
4、保护功能/PROTECTION FUNCTION.....	5
5、环境要求/ENVIRONMENTAL REQUIREMET.....	5~6
6、安全及 EMI 要求/SAFETY AND EMC REQUIREMENT.....	6
7、结构参数/MECHANICAL REQUIREMENT.....	7
8、线材/CORD.....	8
9、包装说明/PACKING.....	8-9
10、标贴/LABEL.....	9

1、描述 / DESCRIPTION:

本规格书适用于 JYH32-1205000 型号的开关电源.

The purpose of the document is to specify the functional requirements of a 60W switching power supply.

2、输入特性 / INPUT CHARACTERISTICS:

2.1 输入电压 / Input Voltage:

额定电压 / Rated Voltage: 100~240Vac

调整范围 / Variation Range: 90-264Vac

2.2 输入频率 / Input Frequency:

额定频率 / Rated Frequency: 50/60Hz.

调整频率 / Variation Frequency: 47-63Hz

2.3 输入电流 / Input Current:

当输入交流电压为额定值的下限电压负载满载时,最大输入交流电流 1.5A.

1.5Amps max At any input voltage and rated, DC output rated load.

2.4 浪涌电流 / Inrush Current:

当输出为额定负载,环境温度为 25℃,输入 240Vac 冷态起机时的最大浪涌电流小于 120A.

120 Amps Max. Cold start at 240Vac input, with rated load and 25°C ambient.

2.5 AC 漏电流 / Ac Leakage Current:

当输入电压 240Vac 时,最大漏电流为 0.75mA.

0.75mA Max. At 240Vac input.

3、输出特性/OUTPUT CHARACTERISTICS:

3.1 输出功率/Power output

电压 Voltage	最小负载 Min. Load	额定负载 Rated. Load	空载功耗 Standby power	输出功率 Output power
12Vdc	0A	5A	0.21W Max	60W

3.2 负载特性,调整率/Combined Load/Line Regulation

电压 Voltage	最小负载 Min. Load	额定负载 Rated. Load	线性调整 Line Regulation	负载调整 Load Regulation
12Vdc	0A	5A	±1%	±5%

3.3 纹波和噪音 Ripple and Noise:

测试条件:在额定电压及额定负载条件下,使用示波器带宽为 20MHz 连接到充电器的输出端,同时输出端并联一个 47uF 的电解电容和一个 0.1uF 的瓷片电容.

Under nominal voltage and nominal load,the ripple and noise are as follows when measure with Max.Bandwidth of 20MHz and Parallel 47uF/0.1uF,crossed connected at testing point.

电压 Voltage	最大纹波/最大噪音 Ripple and Noise(Max.)
+12Vdc	120mV p-p

3.4 启动延迟时间/Turn on delay time:

当输入 115Vac 和输出最大负载时,最大启动时间为 3S.
3Second Max.at 115Vac input and output Max.load.

3.5 上升时间/Rise time:

当输入 115Vac 和输出最大负载时最大时间为 40 mS.
40 mS Max.at 115Vac input and output Max load.

3.6 保持时间/Hold up time:

当输入 115Vac 和输出最大负载时,最小保持时间为 5 mS .
5 mS Min.at 115Vac input and output Max.Load.

3.7 效率/Efficiency:

当 115/230Vac 输入电压时, 1/4, 1/2, 3/4 和满载计算平均效率, 最小 **88%**.
88% Min, At 115/230Vac input voltage,1/4, 1/2, 3/4 and full load calculation average Efficiency.

4、保护功能/PROTECTION FUNCTION:

4.1 短路测试/Short circuit test:

该电源供给器在短路解除时能正常工作恢复.

The power supply will be auto recovered when short circuit faults remove.

4.2 过压保护/Over Voltage Protection:

当输出电压超过额定电压的 120%~170%时,电源将保护,故障排除后能恢复正常工作.

The power supply will auto recovered when faults remove 120%~170%.

5、环境要求/ENVIRONMENTAL REQUIREMET:

5.1 工作温度/Operating Temperature:

0°C-40°C,满载,正常工作.

0°C to 40°C, Full load, Normal operation.

5.2 储藏温度/Storage Temperature:-20°C to 80°C

带外壳/With package

5.3 工作湿度/Relative Humidity:

5%(0°C)~90%(40°C),72 小时,满载,正常工作.

5%(0°C)~90%(40°C)RH,72Hrs,Full load, Normal operating.

5.4 振动/Vibration:

1. 测试标准:国际电工电子委员会

Operating: IEC 721-3-3 3M3

5~9Hz,A=1.5mm

加速度(9~200Hz,Acceleration 5m/S²)

2. 运输/Transportation:

IEC 721-3-2 2M2

5~9Hz,A=3.5mm

9~200Hz,加速度 Acceleration=5m/S²

200~500Hz,加速度 Acceleration=15m/S²

3. 轴向振动/Axes,10 cycles per axis.

在测试过程中不能出现永久性的损坏.

No permanent damage may occur during testing.

在电源开启和关闭后,样机能够恢复到最初条件.

The SAMPLE has to restore to its original situation after power off/on..

5.5 跌落试验/Dropping Packed:

插墙式跌落高度为 1 米、桌面式跌落高度为 760mm;

1M for wallmount type and 760mm for desktop type as above described.

测试台面是厚 13mm 的夹木板,离地面高 19-20mm

The horizontal surface consists of hardwood at least 13mm thick, mounted on two layers of plywood each 19mm to 20mm thick,all supported on a concrete or equivalent non-resilient floor.

6、安全要求/SAFETY REQUIREMENT:

6.1 高压/DIELECTRIC STRENGTH Hi-Pot:

初级对次级: 1800Vac / 3.5mA / 60 秒(生产时高压测试时间: 3 秒)

或 2545Vdc / 3.5mA / 60 秒(生产时高压测试时间: 3 秒)

Primary to Secondary: 1800Vac / 3.5mA / 60 seconds(3 seconds for production)

or 2545Vdc / 3.5mA / 60 seconds(3 seconds for production)

6.2 绝缘抗阻/Insulation resistance:

在初级与次级间加 500Vdc 进行测试,最小 20MΩ

20MΩ min. at primary to secondary add a 500Vdc test voltage

6.3 漏电流/Leakage Current

在输入 264Vac/50Hz 的条件下最大 0.75mA

0.75mAmax. at 264Vac / 50Hz

6.4 安全:符合标准 TUV/GS-(EN60950-1),CCC-(GB4943) AS/NZS: 60950-1, UL/CUL-(UL60950-1)

Safety: accord with TUV/GS-(EN60950-1),CCC-(GB4943) AS/NZS: 60950-1, UL/

CUL-(UL60950-1)

6.5 EMI 标准/EMI STANDARD

Meets the Limits of/测试符合

<1>.Fcc part15 class B rules

<2>.EN55022 class B rules

<3>.GB9254-1998,GB17625.1-2003

7、 结构参数/MECHANICAL REQUIREMENT:

7.1 外壳/Enclosure:外壳尺寸: L120 x W53 x H32mm;The power supply size: L120 x W53 x H32mm;

7.2 输入线/Input Connector:IEC-320-C14.

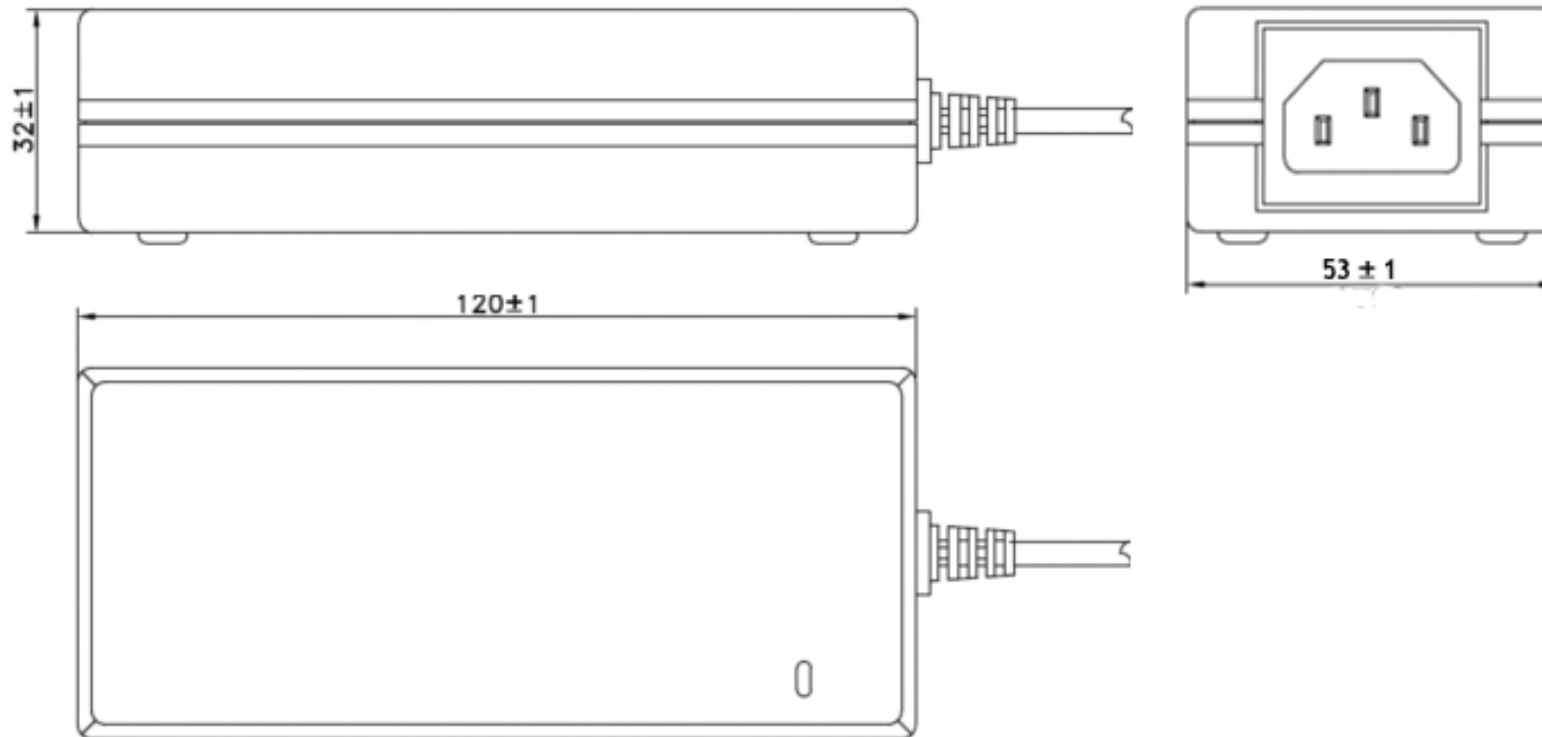

8、CORD/线材



IP40 M16 3PINS 16#AWG DC cable

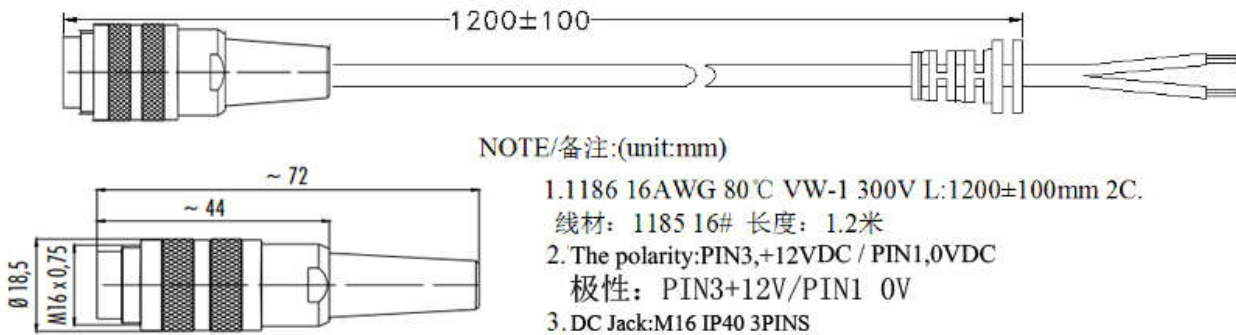

9、包装说明/PACKING(50PCS/CTN,13.2KG/CTN):

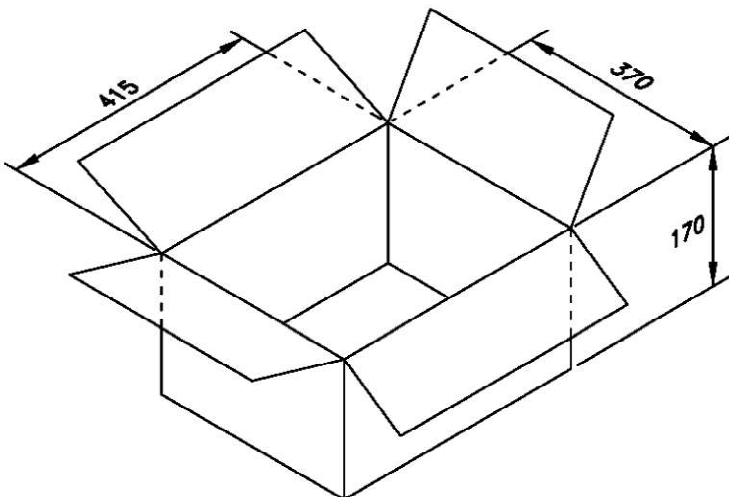

备注:

- 1.纸箱材质为A=B
抗张力14公斤/cm²
- 2.外箱尺寸为外部尺寸,公差为: +5,-0.
- 3.装箱方式: 以50pcs为一层,共装一层,共计
50PCS/箱

9、包装说明/PACKING:

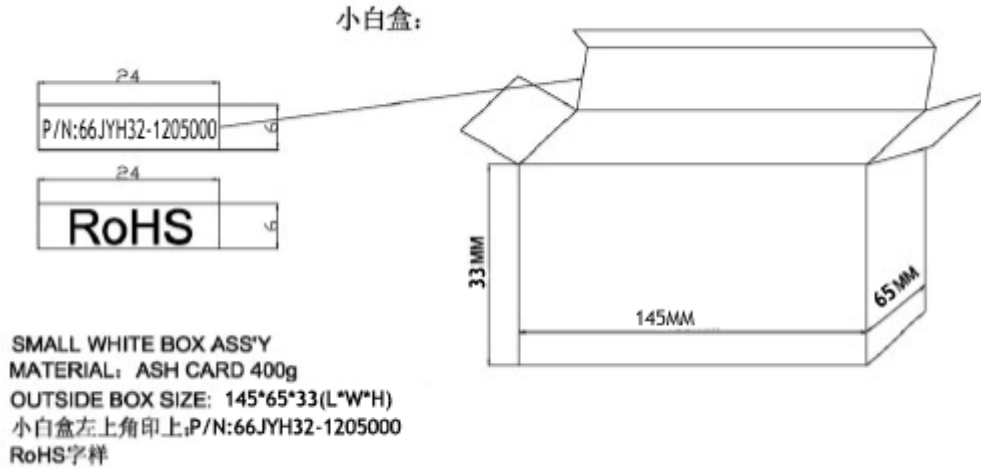

10、标贴/LABEL:

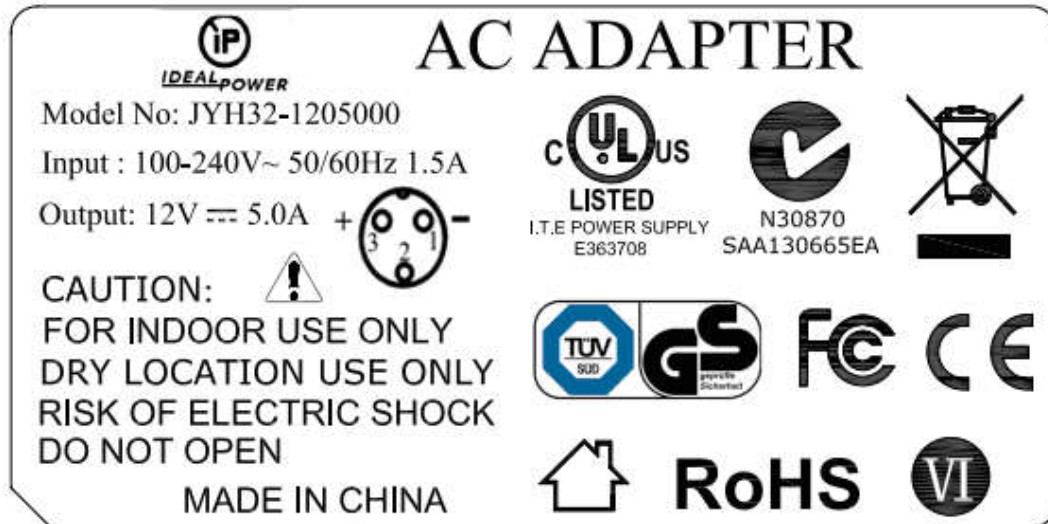

Note:1.材质/MATERIAL:PET

SILVER characters BLACK background/黑底银字

2.厚度/Thickness:0.2mmT±0.1mm

3.环保/ROHS