

Product Data Sheet 4484 FM

ebmpapst

Die Wahl der Ingenieure



4484 FM

INDEX

1 General 3

2 Mechanics 3

 2.1 General 3

 2.2 Connections 3

3 Operating Data 5

 3.1 Operating Data - Electrical Interface - Input 5

 3.2 Electrical Operating Data 6

 3.3 Operating Data - Electrical Interface -Output 6

 3.4 Electrical Features 6

 3.5 Aerodynamic 8

 3.6 Sound Data 9

4 Environment 9

 4.1 General 9

 4.2 Climatic requirements*) 9

5 Safety 10

 5.1 Electrical Safety 10

 5.2 Approval Tests 10

6 Reliability 10

 6.1 General 10

1 General

Fan type	Fan	
Rotational direction looking at rotor	counterclockwise	
Airflow direction	Air outlet over struts	
Bearing system	Ball bearing	
Mounting position	any	

2 Mechanics**2.1 General**

Width	119,0 mm	
Height	119,0 mm	
Depth	25,4 mm	
Weight	0,165 kg	
Housing material	Plastic	
Impeller material	Plastic	
Max. torque when mounted across both mounting flanges	wire outlet corner: 40 Ncm remaining corners: 10 Ncm	
Screw size	ISO 4762 - M4 degreased, without an additional brace and without washer	

2.2 Connections

Electrical connection	Plug	
Length of lead wire		
Tolerance		
Wire gauge (AWG)		
Insulation diameter		
Contact	see drawing	

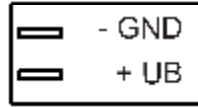

3 Operating Data

3.1 Operating Data - Electrical Interface - Input

Control input	None
---------------	------

3.2 Electrical Operating Data

Measurement conditions: Normal air density = 1,2 kg/m³; Temperature 23°C +/- 3°C; Motor axis horizontal; warm-up time before measuring 5 minutes (unless otherwise specified). In the intake and outlet area should not be any solid obstruction within 0,5 m.

$\Delta p = 0$: corresp. to free air flow (see section 3.5)
 I: corresp. to arithm. mean current value

Features	Condition	Symbol	Values		
Voltage range	$\Delta p = 0$	U	12,0 V		28,0 V
Nominal voltage	$\Delta p = 0$	U_N		24,0 V	
Power consumption	$\Delta p = 0$	P	0,8 W	3,1 W	4,3 W
Tolerance	0001		+/- 17,5 %	+/- 12,5 %	+/- 15,0 %
Current consumption	$\Delta p = 0$	I	65 mA	130 mA	155 mA
Tolerance	0001		+/- 17,5 %	+/- 12,5 %	+/- 15,0 %
Speed	$\Delta p = 0$	n	1.350 1/min	2.400 1/min	2.750 1/min
Tolerance	0001		+/- 12,5 %	+/- 7,5 %	+/- 10,0 %

3.3 Operating Data - Electrical Interface -Output

Tacho type	None
------------	------

Alarm type	None
------------	------

3.4 Electrical Features

Electronic function	None	
Reversed polarity protection	Rectifying diode	
Max. residual current at U_N	$I_F < 100 \mu A$	
Locked rotor protection	Auto restart	
Locked rotor current at U_N	approx. 300 mA	
Clock signal t_3/t_4 at locked rotor	Typical: 0,6 s / 10 s	

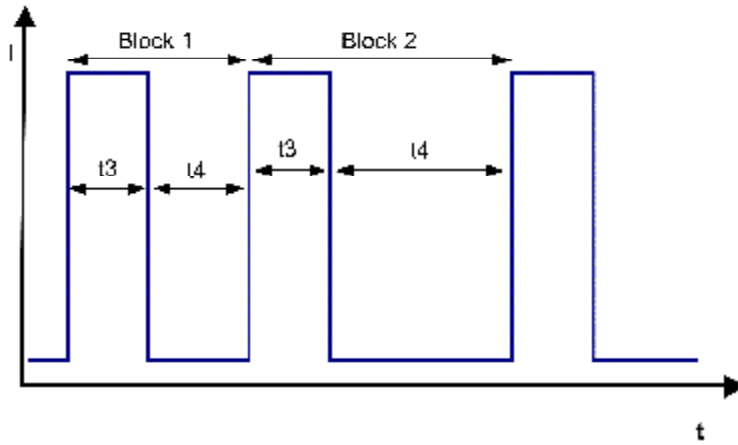

Block1: special locked rotor protection: 5 cycles $t_3 / t_4 = 0,6 \text{ s} / 0,5 \text{ s}$ Block2: locked rotor protection $t_3 / t_4 = 0,6 \text{ s} / 10 \text{ s}$

3.5 Aerodynamic

Measurement conditions: Measured with a double chamber intake rig acc. to DIN EN ISO 5801.
 Normal air density = 1,2 kg/m³; Temperature 23°C +/- 3°C;
 In the intake and outlet area should not be any solid obstruction within 0,5 m.
 The information is only valid under the specified test conditions and may be changed by the installation conditions. If there are deviations from the standard test conditions, the characteristic values must be checked under the installed conditions.

a.) Operation condition:

2.400 1/min at free air flow

Max. free-air flow ($\Delta p = 0 / \dot{V} = \text{max.}$)	137,0 m ³ /h	
Max. static pressure ($\Delta p = \text{max.} / \dot{V} = 0$)	45 Pa	

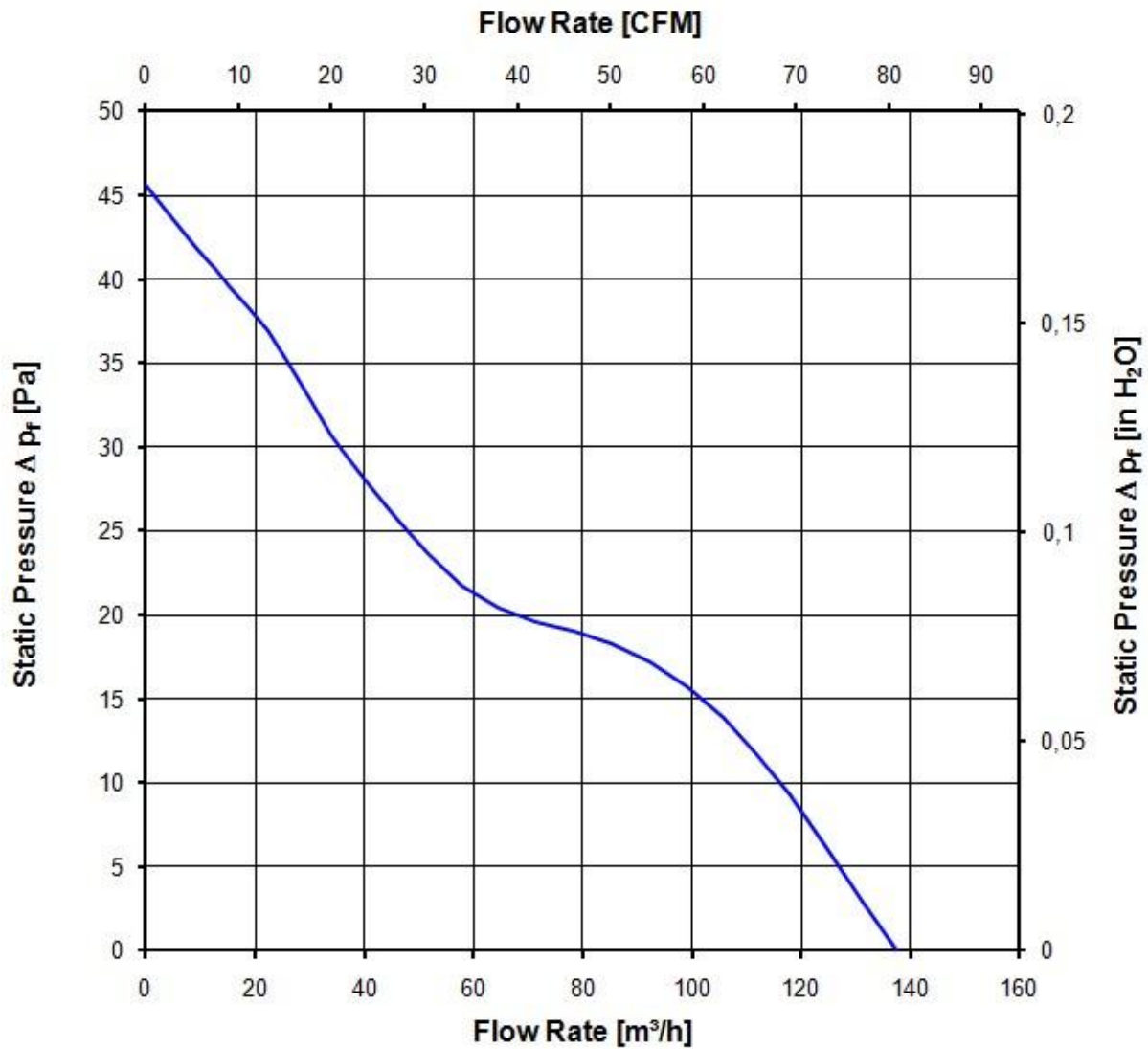

3.6 Sound Data

Measurement conditions: Sound pressure level: 1 Meter distance between microphone and the air intake.
 Sound power level: Acc. to DIN 45635 part 38 (ISO 10302)
 Measured in a semianchoic chamber with a background noise level of $L_p(A) < 5 \text{ dB}(A)$
 For further measurement conditions see section 3.5

a.) Operation condition:

2.400 1/min at free air flow

Optimal operating point	104,0 m ³ /h @ 13 Pa	
Sound power level at the optimal operating point	4,9 bel(A)	
Sound pressure level at free air flow, measured in rubber bands	38,0 dB(A)	

4 Environment

4.1 General

Min. permitted ambient temperature TU min.	-20 °C	
Max. permitted ambient temperature TU max.	75 °C	
Min. permitted storage temperature TL min.	-40 °C	
Max. permitted storage temperature TL max.	80 °C	

4.2 Climatic requirements *)

Humidity requirements	humid heat, constant; according to DIN EN 60068-2-78, 14 days	
Water exposure	None	
Dust requirements	None	
Salt fog requirements	None	

*) Permitted application area:

The product is intended for use in sheltered rooms with controlled temperature and controlled humidity. Directly exposure to water must be avoided.

Pollution degree 1 (according DIN EN 60664-1)

There is either no pollution or it occurs only dry, non-conductive pollution. The pollution has no negative impact.

Please require severity levels and specification parameters from the responsible development departments

5 Safety

5.1 Electrical Safety

Dielectric strength DIN EN 60950 (VDE 0805) and DIN EN 60335 (VDE 0700) A.) Type test Measuring conditions: After 48h of storage at 95% R.H. and 25°C. No arcing or breakdown is allowed! All connections together to ground.	500 VAC / 1 Min.	
B.) Routine test Measuring conditions: At indoor climate. No arcing or breakdown is allowed! All connections together to ground.	500 VAC / 1 Sec.	
Isolation resistance Measuring conditions: After 48h of storage at 95% R.H. and 25°C measured with U=500 VDC for 1 min.	RI > 10 MOhm	
clearance / creepage distance	1,0 mm / 1,2 mm	
Protection class	III	

5.2 Approval Tests

CE	EC Declaration of Conformity	Yes
EAC	Eurasian Conformity	Yes
UL	Underwriters Laboratories	Yes / UL audited by CSA according to UL507, Electric Fans
VDE	Association for Electrical, Electronic and Information Technologies	Yes / Approval acc. to EN 60950 (VDE 0805) - Information technology equipment
CSA	Canadian Standards Association	Yes / C22.2 No. 113 Fans and Ventilators
CCC	China Compulsory Certification	No

6 Reliability

6.1 General

Life expectancy L10 at TU = 40 °C	70.000 h	
Life expectancy L10 at TU max.	30.000 h	
Life expectancy L10 Delta (40 °C)	135.000 h	

Content of this document, and parts of it, to others and the use or communication of
 the contents thereof, are prohibited, unless express written permission has been
 granted by the manufacturer. The manufacturer shall not be held responsible for
 damage or the modification of a third party's design.

Schlüssel nach DIN 4710 beachten

082
 210
 232
 235
 240
 243
 315x
 516

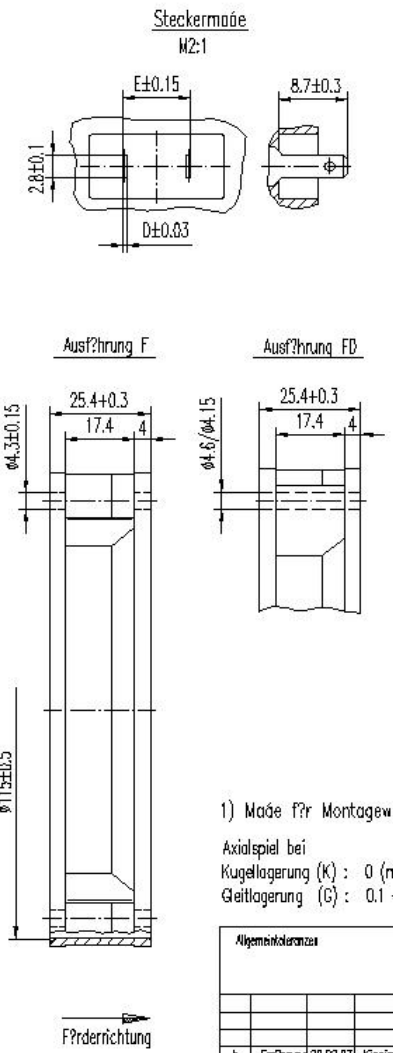
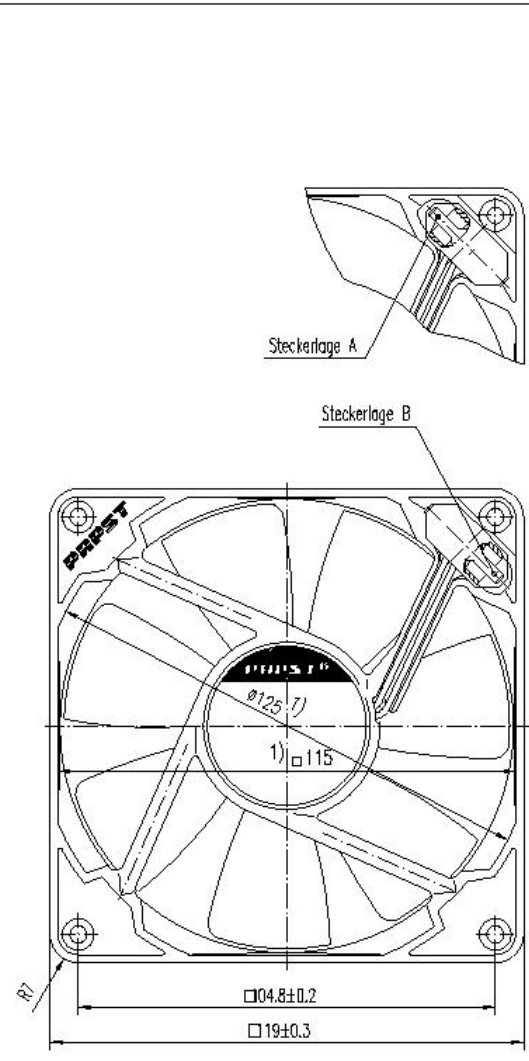

Erzeugnis-Nr.	Typ	Lagersystem K=Kugellager G=Gleitlager	Geißel- ausführung	Steckerlage	Steckermaße	
					D	E
929 3505 400	4484 F	K	F	B	0.5	8.5
929 3505 402	4484 FD	K	FD	B	0.5	8.5
929 3505 403	4484 FW	K	F	B	0.5	8.5
929 3505 404	4484 FWD	K	FD	B	0.5	8.5
929 3505 411	4482 FW	K	F	B	0.5	8.5
929 3505 412	4482 FWD	K	FD	B	0.5	8.5
929 3505 426	4484 FG	G	F	B	0.5	8.5
929 3505 439	4482 FGM	G	F	B	0.5	8.5

1) Maße für Montagewand
 Axialspiel bei
 Kugellagerung (K) : 0 (mit Federausgleich)
 Gleitlagerung (G) : 0.1 – 0.6

Allgemeinkolonne				Arbeits-		Monat	
				Axialfilter		1:1	
						(2:1)	
b	Erzeugung	20.02.97	Kieninger	Zchg.-Nr.	929 3505 400		Blatt 2
a	Erzeugung	13.05.96	Kieninger				
Index	Znd.-Nr.	Datum					
Zur Verwendung im Verteiler freigegeben von Koletzki M. am 21.02.97				PAPST-MOTOREN GmbH & Co KG D-78112 St. Georgen Germany		Ers.f.Zchg: gl.Nr.v.17.06.94 P:\029\3505\	