



The engineer's choice

ebmpapst

4656 ZW

INDEX

1 General 3

2 Mechanics 3

2.1 GENERAL 3

2.2 CONNECTIONS 4

3 Operating Data 5

3.1 ELECTRICAL OPERATING DATA 5

3.2 OPERATING DATA - ELECTRICAL INTERFACE -OUTPUT 6

3.3 ELECTRICAL FEATURES 6

3.4 AERODYNAMIC 6

3.5 SOUND DATA 7

4 Environment 7

4.1 GENERAL 7

4.2 CLIMATIC REQUIREMENTS*) 7

5 Safety 8

5.1 ELECTRICAL SAFETY 8

5.2 APPROVAL TESTS 8

6 Reliability 8

6.1 GENERAL 8

1 General

Fan type	Fan
Rotational direction looking at rotor	clockwise
Airflow direction	Air outlet over struts
Bearing system	Ball bearing
Mounting position	any
Balancing grade	2,5

2 Mechanics**2.1 General**

Width	119,0 mm	
Height	119,0 mm	
Depth	38,0 mm	
Diameter	0,0 mm	
Weight	0,540 kg	
Housing material	Metal	
Impeller material	Metal	
Max. torque when mounted across both mounting flanges	wire outlet corner: 120 Ncm remaining corners: 350 Ncm	
Screw size	ISO 4762 - M4 degreased, without an additional brace and without washer	

2.2 Connections

Electrical connection	Wires	
Length of lead wire	L = 310,0 mm	
Tolerance	+/- 10,0 mm	
Length of tube	see drawing	
Tolerance		
Wire gauge (AWG)	18	
Insulation diameter	2,06 mm	
Plug	see drawing	
Contact	see drawing	



	Colour	Operation
Wire 1	black	L
Wire 2	black	N

3 Operating Data

3.1 Electrical Operating Data

Measurement conditions: Normal air density = 1,2 kg/m³; Temperature 23°C +/- 3°C; Motor axis horizontal; warm-up time before measuring 5 minutes (unless otherwise specified).
In the intake and outlet area should not be any solid obstruction within 0,5 m.

$\Delta p = 0$: corresp. to free air flow (see section 3.4)

I: corresp. to RMS line current

Features	Condition	Symbol	Values	
Frequency	$\Delta p = 0$	f	50 Hz	60 Hz
Nominal voltage	$\Delta p = 0$	U_N	230,0 V	230,0 V
Tolerance			+ 6,0 % - 10,0 %	+ 6,0 % - 10,0 %
Power consumption	$\Delta p = 0$	P	19,0 W	17,0 W
Tolerance			+/- 10,0 %	+/- 10,0 %
Speed	$\Delta p = 0$	n	2.650 1/min	3.100 1/min
Tolerance			+/- 3,0 %	+/- 3,0 %

3.2 Operating Data - Electrical Interface -Output

Tacho type	None
------------	------

3.3 Electrical Features

Locked rotor protection	Impedance
Locked rotor current at U_n	

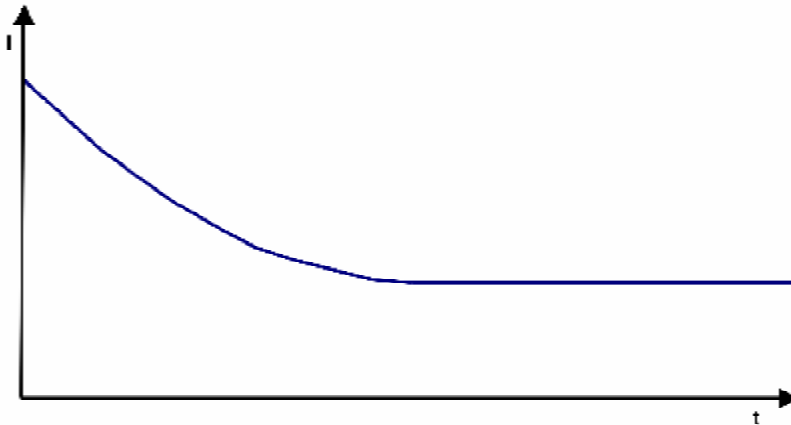

3.4 Aerodynamic

Measurement conditions: Measured with a double chamber intake rig acc. to DIN EN ISO 5801.
Normal air density = 1,2 kg/m³; Temperature 23°C +/- 3°C;
In the intake and outlet area should not be any solid obstruction within 0,5 m.

a.) Operation condition:
2.650 1/min at free air flow Frequency: 50 Hz

Max. free-air flow ($\Delta p = 0 / \dot{V} = \max.$)	152,0 m ³ /h
Max. static pressure ($\Delta p = \max. / \dot{V} = 0$)	70 Pa

b.) Operation condition:
3.100 1/min at free air flow Frequency: 60 Hz

Max. free-air flow ($\Delta p = 0 / \dot{V} = \max.$)	180,0 m ³ /h
Max. static pressure ($\Delta p = \max. / \dot{V} = 0$)	80 Pa

3.5 Sound Data

Measurement conditions: Sound pressure level: 1 Meter distance between microphone and the air intake.
 Sound power level: Acc. to DIN 45635 part 38 (ISO 10302)
 Measured in a semianchoic chamber with a background noise level of $L_p(A) < 5 \text{ dB(A)}$
 For further measurement conditions see section 3.4

a.) Operation condition:
 2.650 1/min at free air flow Frequency: 50 Hz

Optimal operating point	130,0 m ³ /h @ 15 Pa	
Sound power level at the optimal operating point	5,1 bel(A)	
Sound pressure level at free air flow, measured in rubber bands	37,0 dB(A)	

b.) Operation condition:
 3.100 1/min at free air flow Frequency: 60 Hz

Optimal operating point	148,0 m ³ /h @ 20 Pa	
Sound power level at the optimal operating point	5,5 bel(A)	
Sound pressure level at free air flow, measured in rubber bands	42,0 dB(A)	

4 Environment

4.1 General

Min. permitted ambient temperature TU min.	-40 °C / 50 Hz -40 °C / 60 Hz	
Max. permitted ambient temperature TU max.	75 °C / 50 Hz 85 °C / 60 Hz	
Min. permitted storage temperature TL min.	-40 °C	
Max. permitted storage temperature TL max.	100 °C	

4.2 Climatic requirements *)

Humidity requirements	humid heat, constant; according to DIN EN 60068-2-78, 14 days	
Water exposure	None	
Radiation exposure	None	
Dust requirements	None	
Salt fog requirements	None	
Harmful gas requirements	None	

*) Permitted application area:

The product is intended for use in sheltered rooms with controlled temperature and controlled humidity. Directly exposure to water must be avoided.

Pollution degree 1 (according DIN EN 60664-1)

There is either no pollution or it occurs only dry, non-conductive pollution. The pollution has no negative impact.

5 Safety

5.1 Electrical Safety

Dielectric strength DIN EN 60950 (VDE 0805) and DIN EN 60335 (VDE 0700) A.) Type test Measuring conditions: After 48h of storage at 95% R.H. and 25°C. No arcing or breakdown is allowed! All connections together to ground. B.) Routine test Measuring conditions: At indoor climate. No arcing or breakdown is allowed! All connections together to ground.	1500 VAC / 1 Min. 1500 VAC / 1 Sec.
Isolation resistance Measuring conditions: After 48h of storage at 95% R.H. and 25°C measured with U=500 VDC for 1 min.	RI > 50 MOhm
Air and leakage distances	2,0 mm / 1,8 mm
Protection class	I

5.2 Approval Tests

CE	Yes
UL	Yes / UL507, Electric Fans
VDE	Yes / Approval acc. to EN 60950 (VDE 0805) - Information technology equipment
CSA	Yes / C22.2 No. 113 Fans and Ventilators
CCC	Yes / GB 12350 Safety Requirements for small Power Motors

The approval tests are observed to:

U approval max.: 230 V / f: 60 Hz @ TU approval max.: 85 °C

6 Reliability

6.1 General

Life expectancy L10 at TU = 40 °C	37.500 h / 50 Hz 40.000 h / 60 Hz	
Life expectancy L10 at TU max.	17.500 h / 50 Hz 15.000 h / 60 Hz	

Copying of this document, regardless of its origin and the use or communication of the contents thereof, are prohibited without the prior written permission of the manufacturer or distributor of the product.

Schweißmuster ist nach DIN ISO 5456 beschleunigt Referenz zu internationaler Norm DIN ISO 9001

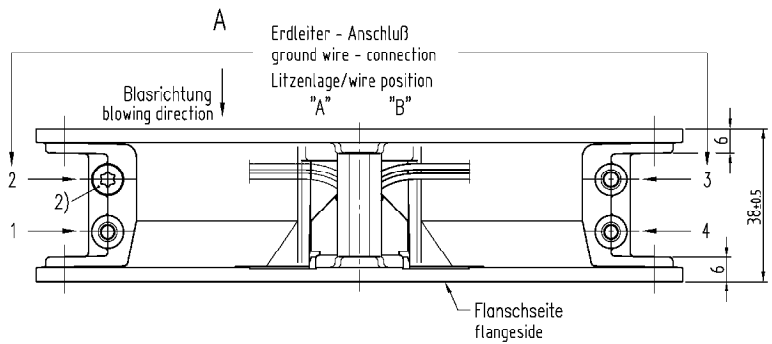
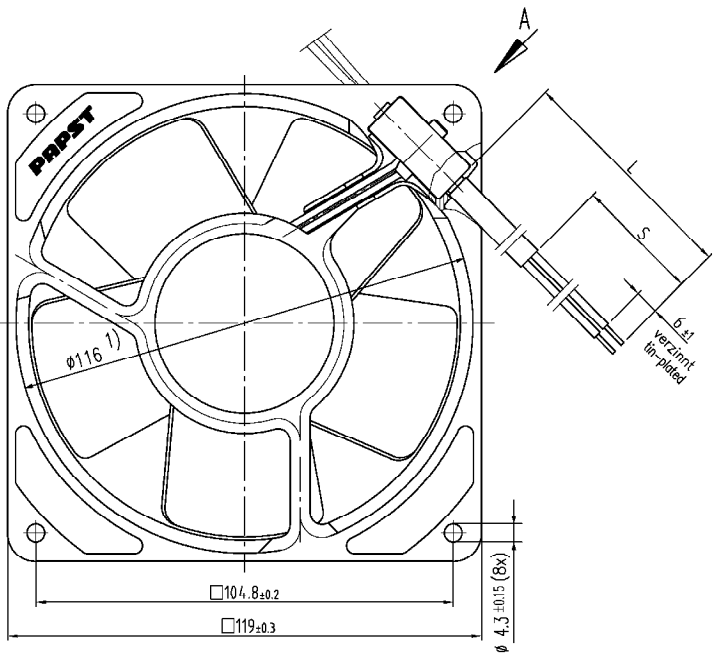

Anzahl und Länge der Litzen sowie
 Schlauchlänge, Litzenlage und Erdleiter-Anschluß s. Spezifikation
 length and number of wires and of tube length,
 wires length and ground wire -connection see design specification

- 1) Maße für Montagewand
- 2) Schraube: Duo-Tapfite nach DIN 7500, CM 4x8, Torx

- 1) dimensions for assembly wall
- 2) Screw: Duo-Tapfite to DIN 7500, CM 4x8, Torx

- Axialspiel bei
- Kugellagerung (K): 0 (mit Federausgleich)
 - Gleitlagerung (G): 0.1 - 0.6
 - Gleitlagerung (GF): 0 (mit Federausgleich)

- axial clearance by
- ball bearing (K): 0 (with spring compensation)
 - sleeve bearing (G): 0.1 - 0.6
 - sleeve bearing (GF): 0 (with spring compensation)

SAP-Status/State		Anm.-Nr./Change-No.		ebmpapst		Werks/Off./Material:		Volumen/Volume [cm ³]:	
		Anm./CAD-System-Version		CAD-Umgebung/ CAD-Environment		Name/Name		Gewicht/Mass [g]:	
Tolerierung/Tolerances:		Datum/Date		Name/Name		Artikel/Title			
Allgemeintoleranzen/gen. tolerances		Gezeichnet/ Drawn Geprüft/ Checked Freigegeben/ Released				Zchg.-Nr./Drawing-No.:		Ers.f.Zchg./Replaces:	
		ebm-papst St. Georgen GmbH & Co. KG		Dokument/Type of Document		Teilenummer/Part/No.		Index/Index	
				Format/Size		Massstab/Scale			