



# Table of Contents

---

<b>1</b>	<b>TWR-KL46Z .....</b>	<b>3</b>
<b>2</b>	<b>Contents .....</b>	<b>4</b>
<b>3</b>	<b>TWR-KL46Z Features .....</b>	<b>4</b>
<b>4</b>	<b>Get to Know the TWR-KL46Z.....</b>	<b>5</b>
<b>5</b>	<b>Reference Documents .....</b>	<b>5</b>
<b>6</b>	<b>Hardware description.....</b>	<b>6</b>
	6.1 Block Diagram .....	6
	6.2 Microcontroller.....	7
	6.3 Clocking.....	9
	6.4 System Power .....	9
	6.5 Real Time Clock (RTC).....	9
	6.6 Debug Interface .....	9
	6.7 UART .....	10
	6.8 Infrared Port.....	10
	6.9 Accelerometer .....	11
	6.10 General Purpose Tower Plug-in (TWRPI) Socket.....	12
	6.11 Potentiometer, Pushbuttons, LEDs.....	13
	6.12 Touch Interface TWRPI/sLCD.....	13
	6.13 USB .....	14
<b>7</b>	<b>TWR-KL46Z Jumper options.....</b>	<b>14</b>
<b>8</b>	<b>Useful links .....</b>	<b>16</b>

## 1 TWR-KL46Z

---

The TWR-KL46Z microcontroller module is designed to work either in standalone mode or as part of the Freescale Tower System, a modular development platform that enables rapid prototyping and tool re-use through reconfigurable hardware. Take your design to the next level and begin constructing your Tower System today by visiting [www.freescale.com/tower](http://www.freescale.com/tower) for additional Tower System microcontroller modules and compatible peripherals. For TWR-KL46Z specific information and updates visit [www.freescale.com/TWR-KL46Z](http://www.freescale.com/TWR-KL46Z)

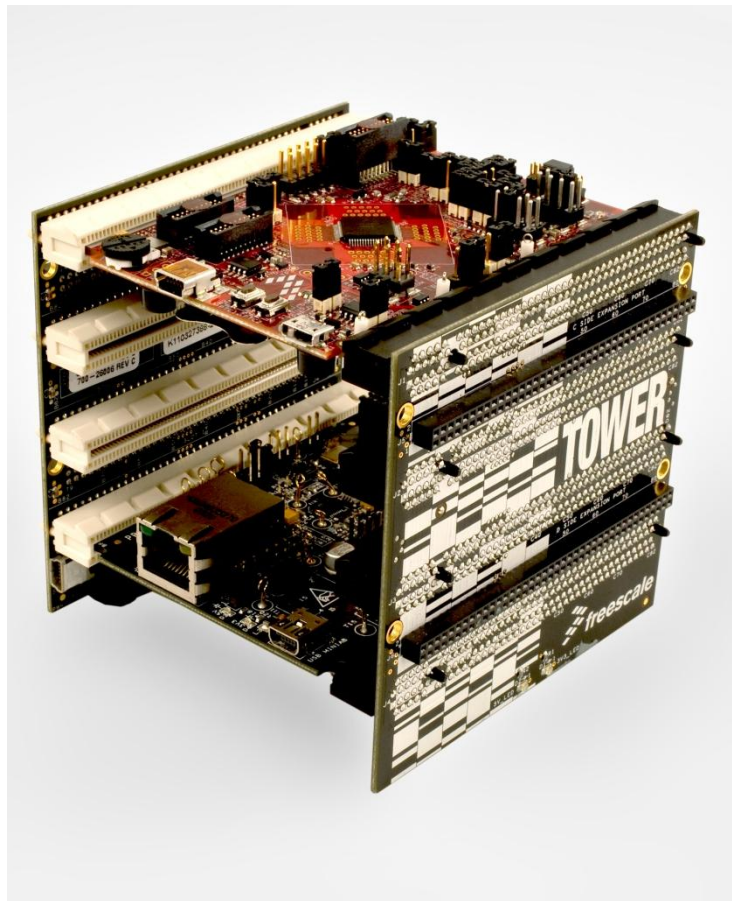

Figure 1 Freescale Tower System Overview

---

## 2 Contents

---

The TWR-KL46Z contents include:

- TWR-KL46Z board assembly
- 3ft A to mini-B USB cable for debug interface and power
- 3ft A to micro-B USB cable for MKL46Z256VLL4 USB interface
- Micro-B to A adapter for MKL46Z256VLL4 USB Host applications
- Quick Start Guide
- TWRPI-sLCD

## 3 TWR-KL46Z Features

---

- Tower compatible microcontroller module
- MKL46Z256VLL4 MCU (48 MHz, 256KB Flash, 32 KB RAM, segment LCD Low power, 100 LQFP package)
- Dual role USB interface with Micro-AB USB connector
- Touch Tower Plug-in/sLCD Socket
- General purpose Tower Plug-in (TWRPI) socket
- On-board debug circuit MK20 openSDA serial debug interface with virtual serial port and mass storage device bootloader
- Three axis accelerometer (MMA8451Q)
- Four user-controllable LEDs
- Two capacitive touch pads
- Two (2) user pushbutton switch
- Infrared transmit and receive
- Potentiometer
- GPIO header for prototyping
- Potentiometer for ADC measurements
- 32.768 clock for RTC operation
- Power selectable 3.3V/1.8V



## 4 Get to Know the TWR-KL46Z

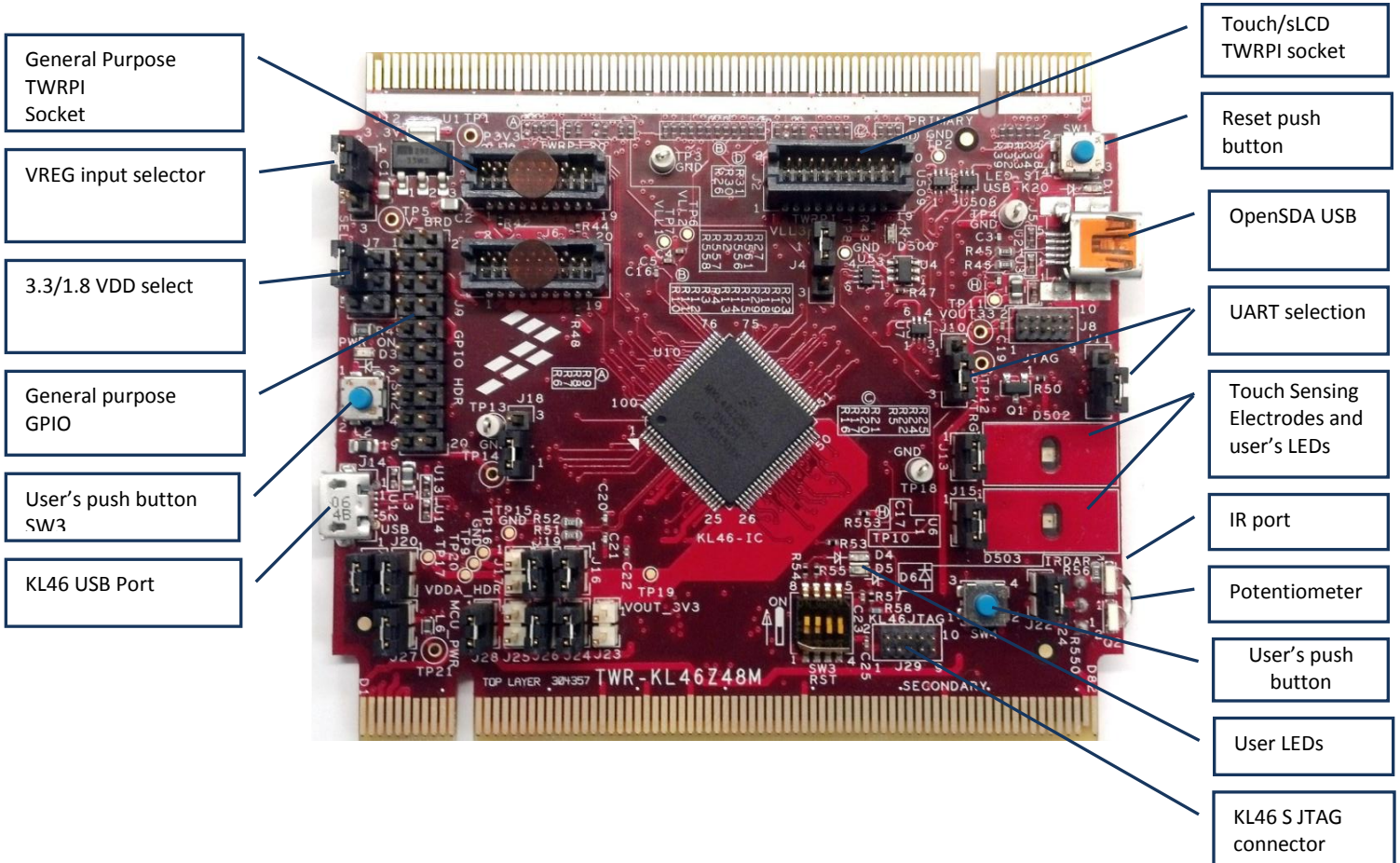

## 5 Reference Documents

The documents listed below should be referenced for more information on the Kinetis family, Tower System, and MCU Modules. These can be found in the documentation section of <http://www.freescale.com/TWR-KL46Z> or <http://www.freescale.com/kinetis>

- TWR-KL46Z48M\_QSG: Quick Start Guide
- TWR- KL46Z48M\_SCH: Schematics
- TWR KL46Z48M\_PWB: Design Package
- MKL46Z256VLL4 Reference Manual
- Tower Configuration Tool
- Tower Mechanical Drawing

## 6 Hardware description

The TWR-KL46Z is a Tower MCU Module featuring the MKL46Z256VLL4—a Kinetis microcontroller with USB 2.0 full-speed OTG controllers in a 64 LQFP package. It is intended for use in the Freescale Tower System but can operate stand-alone. An on-board debug circuit, OSJTAG, provides a JTAG interface and a power supply input through a single USB mini-AB connector.

The block diagram of the TWR-KL46Z board is presented in the following figure:

### 6.1 Block Diagram

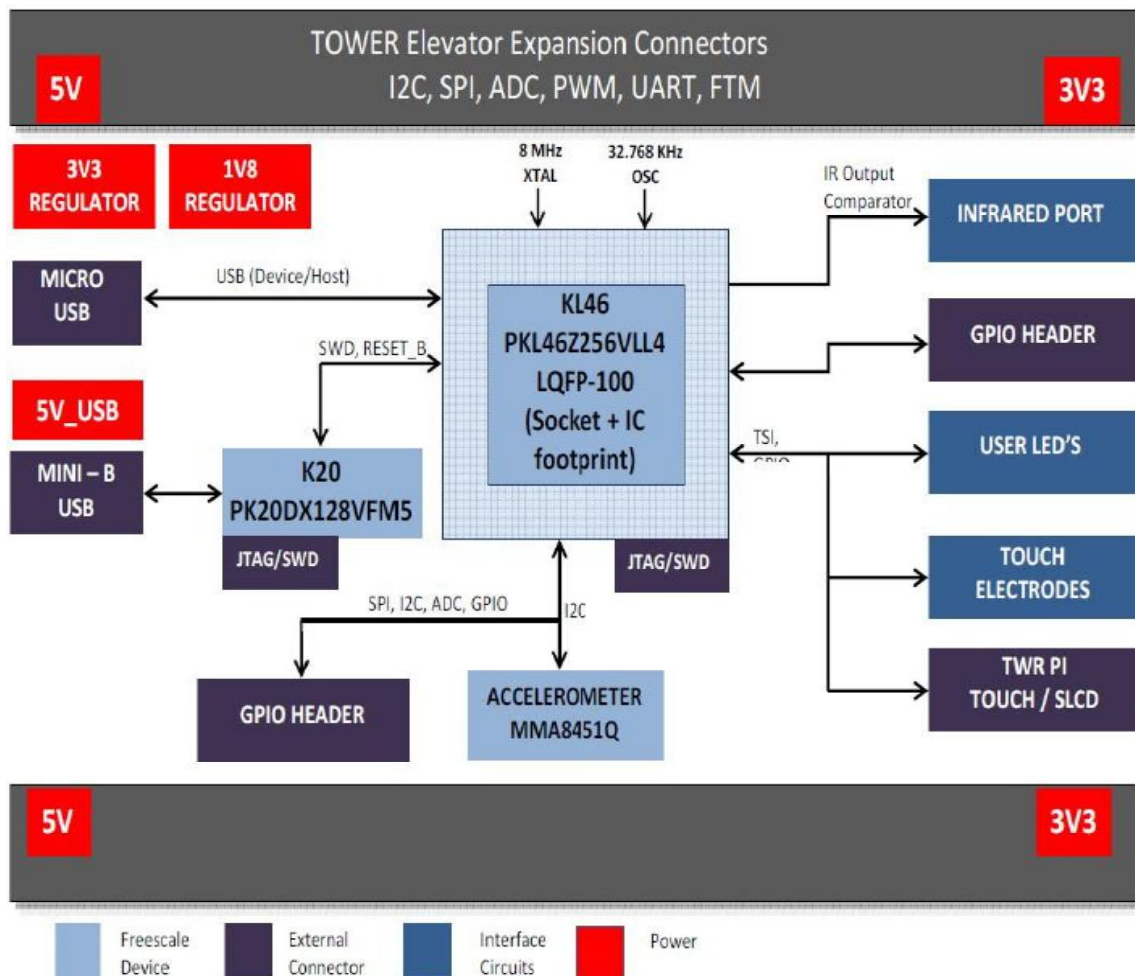

Figure 2 Block Diagram of TWR-KL46Z

## 6.2 Microcontroller

The TWR-KL46Z is a Tower MCU Module featuring the MKL46Z256VLL4 —a Kinetis microcontroller with USB 2.0 full-speed OTG controllers, and segment LCD controller in a 100 LQFP package. It is intended for use in the Freescale Tower System but can operate stand-alone. An on-board debug circuit, openSDA, provides a SWD interface and a power supply input through a single USB mini-AB connector, as well as a serial to USB, and CDC class compliant UART interface.

**Table 1 Features of MKL46Z256VLL4**

Feature	Description
Ultra low power	<ul style="list-style-type: none"> <li>-10 low-power modes with power and clock gating for optimal peripheral activity and recovery times. Stop currents of &lt;190 nA (VLLS0), run currents of &lt;280 uA/MHz, 4 μs wake-up from Stop mode</li> <li>-Full memory and analog operation down to 1.71V for extended battery life</li> <li>-Low-leakage wake-up unit with up to eight internal modules and sixteen pins as wake-up sources in low-leakage stop (LLS)/very low-leakage stop (VLLS) modes</li> <li>-Low-power timer for continual system operation in reduced power states</li> </ul>
Flash, SRAM	<ul style="list-style-type: none"> <li>-256 KB flash featuring fast access times, high reliability, and four levels of security protection. No user or system intervention to complete programming and erase functions and full operation down to 1.71V.</li> <li>-32 KB of SRAM</li> </ul>
Mixed-signal capability	<ul style="list-style-type: none"> <li>- High-speed 12/16-bit analog-to-digital converter (ADC)</li> <li>- Comparator (CMP) with internal 6-bit digital-to-analog converter (DAC)</li> <li>- 12-bit digital-to-analog converter (DAC)</li> </ul>

Feature	Description
Performance	<ul style="list-style-type: none"> <li>- 48 MHz ARM Cortex-M0+ core</li> <li>- Up to four channel DMA for peripheral and memory servicing with reduced CPU loading and faster system throughput - Cross bar switch enables concurrent multi-master bus accesses, increasing bus bandwidth - Independent flash banks allowing concurrent code execution and firmware updating with no performance degradation or complex coding routines</li> <li>- Bit manipulation engine (BME) allows execution of single-instruction atomic bit-modify-write operations on the peripheral address space</li> </ul>
Timing and Control	<ul style="list-style-type: none"> <li>- Low power timers.</li> <li>- Four-channel 32-bit periodic interrupt timer provides time base for RTOS task scheduler or trigger source for ADC conversion</li> </ul>
Human-Machine Interface	<ul style="list-style-type: none"> <li>-Hardware touch-sensing interface (TSI) with up to 16 inputs</li> <li>-TSI operates in low power modes (minimum current adder when enabled)</li> <li>-TSI hardware implementation avoids software polling methods</li> <li>-High sensitivity level allows use of overlay surfaces up to 5 mm thick.</li> <li>-segment LCD controller up to 8X47 or 4x51 segments</li> </ul>
Connectivity and Communications	<ul style="list-style-type: none"> <li>- Full-Speed USB Device/Host/On-The-Go with device charge detect capability</li> <li>- Optimized charging current/time for portable USB devices, enabling longer battery life</li> <li>- USB low-voltage regulator supplies up to 120 mA off chip at 3.3 volts to power external components from 5-volt input</li> <li>- Three UARTs (one UART supports RS232 with flow control, RS485, ISO7816 and IrDA while the other two UARTS support RS232 with flow control and RS485)</li> <li>- One Inter-IC Sound (I2S) serial interface for audio system interfacing</li> <li>- two SPI module</li> <li>-two I2C module</li> </ul>
Reliability, Safety and Security	<ul style="list-style-type: none"> <li>- Memory protection unit provides memory protection for all masters on the cross bar switch, increasing software reliability</li> <li>- Independent-clocked computer operating properly (COP) guards against clock skew or code runaway for fail-safe applications such as the IEC 60730 safety standard for household appliances</li> </ul>



---

## 6.3 Clocking

The Kinetis MCUs start up from an internal digitally controlled oscillator (DCO). Software can enable the main external oscillator (EXTAL0/XTAL0) if desired. The external oscillator/resonator can range from 32.768 KHz up to a 32 MHz. An 8 MHz crystal is the default external source for the MCG oscillator inputs (XTAL/EXTAL). A 32.768 KHz oscillator is connected to the RTC clock input.

## 6.4 System Power

When installed into a Tower System, the TWR-KL46Z can be powered from either an on-board source or from another source in the assembled Tower System.

In stand-alone operation, the main power source (5.0V) for the TWR-KL46Z48M module is derived from either the openSDA USB mini-B connector or the KL46 USB micro-AB connector (J5). Two low-dropout regulators provide 3.3V and 1.8V supplies from the 5.0V input voltage. Additionally, the 3.3V regulator built into the KL46 can be selected to power the 3.3V bus. All the user selectable options can be configured using two headers, J7 and J3.

## 6.5 Real Time Clock (RTC)

Y500 is a 32.768 kHz oscillator connected to RTC\_CLKIN. By enabling the external clock input option in the RTC, it can be used as a highly precise time reference.

## 6.6 Debug Interface

There are two debug interface options provided: the on-board openSDA circuit and an external ARM SWD connector.

### 6.6.1 OpenSDA

An on-board MK20-OpenSDA circuit provides an SWD debug interface to the MKL46Z256. A standard USB A male to mini-B male cable (provided) can be used for debugging via the USB connector, J5. The OpenSDA interface also provides a USB to serial bridge.

### 6.6.2 Cortex Debug SWD Connector

The Cortex Debug SWD connector is a standard 2x5-pin (0.05") connector providing an external debugger cable with access to the SWD interface of the MKL46Z256.

**Table 2 Cortex Debug connector**

Pin	Function	TWR-KL46Z Connection
1	VTref	3.3V MCU supply (MCU_PWR)
2	SWDIO	PTA3/SCIO_RTS_b/FTM0_CH0/SWD_DIO
3	GND	GND
4	SWCLK	PTA0/SCIO_CTS_b/FTM0_CH5 /SWD_CLK
5	GND	GND
6	NC	
7	NC	
8	NC	
9	NC	
10	nRESET	RESET_b

## 6.7 UART

UART2 can be connected to OpenSDA or TWR-Elevators through jumpers J10 and J11

J10 UART2\_TX\_TGTMCU - PTE16/UART2\_TX

J11 UART2\_RX\_TGTMCU - PTE17/UART2\_RX

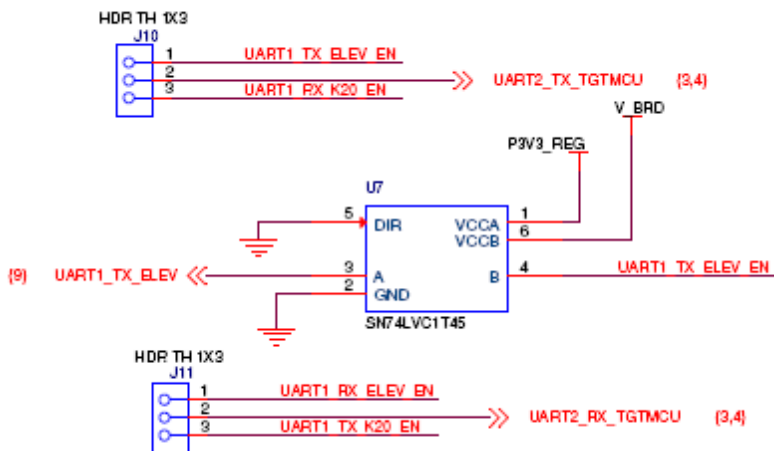

## 6.8 Infrared Port

An infrared transmit and receive interface is implemented as shown in Figure 5. The UART2\_TX pin directly drives an infrared diode. The receiver uses an infrared phototransistor connected to UART2\_RX through a low-

pass filter.

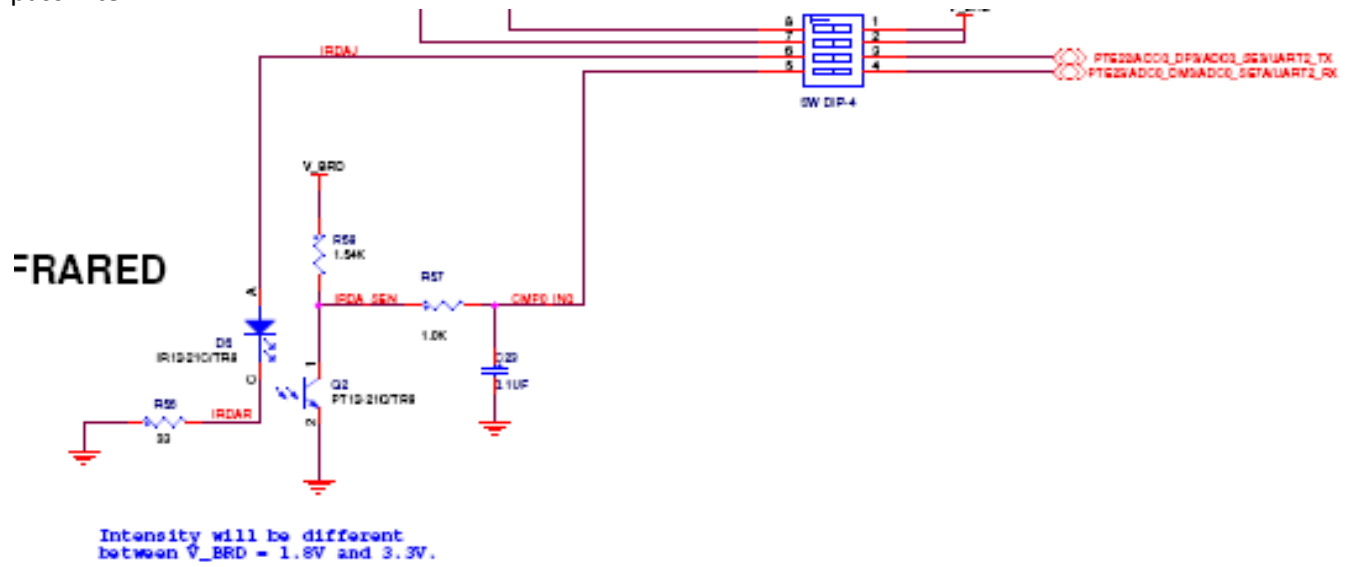

Figure 3 Infrared circuit

## 6.9 Accelerometer

An MMA8451Q digital accelerometer is connected to the MKL46Z256VLL4 MCU through I2C module, I2C1, and GPIO/IRQ signals, PTC10 and PTC11. The MMA8451Q is a smart low-power, three-axis capacitive micromachined accelerometer with 14 bits of resolution. The device can be configured to generate inertial wake-up interrupt signals from any combination of the configurable embedded functions allowing the MMA8451Q to monitor events and remain in a low-power mode during periods of inactivity. For more information on the MMA8451Q, please visit the [MMA8451Q Product Summary Page](#).

## 6.10 General Purpose Tower Plug-in (TWRPI) Socket

The TWR-KL46Z features a socket (J6 and J1) that can accept a variety of different Tower Plug-in modules featuring sensors, RF transceivers, and more. The General Purpose TWRPI socket provides access to I2C, SPI, IRQs, GPIOs, timers, analog conversion signals, TWRPI ID signals, reset, and voltage supplies. The pinout for the TWRPI Socket is defined Table 1Table 3

**Table 3 General Purpose TWRPI socket pinout**

J6		J1	
Pin	Description	Pin	Description
1	5V VCC	1	GND
2	3.3 V VCC	2	GND
3	GND	3	I2C: SCL
4	3.3V VDDA	4	I2C: SDA
5	VSS (Analog GND)	5	GND
6	VSS (Analog GND)	6	GND
7	VSS (Analog GND)	7	GND
8	ADC: Analog 0	8	GND
9	ADC: Analog 1	9	SPI: MISO
10	VSS (Analog GND)	10	SPI: MOSI
11	VSS (Analog GND)	11	SPI: SS
12	ADC: Analog 2	12	SPI: CLK
13	VSS (Analog GND)	13	GND
14	VSS (Analog GND)	14	GND
15	GND	15	GPIO: GPIO0/IRQ
16	GND	16	GPIO: GPIO1/IRQ
17	ADC: TWRPI ID 0	17	GPIO: GPIO2
18	ADC: TWRPI ID 1	18	GPIO: GPIO3
19	GND	19	GPIO: GPIO4/Timer
20	Reset	20	GPIO: GPIO5/Timer

## 6.11 Potentiometer, Pushbuttons, LEDs

The TWR-KL46Z features two pushbutton switches connected to GPIO/interrupt signals, one pushbutton connected to the master reset signal, two capacitive touch pad electrodes, four user-controllable LEDs, and a potentiometer connected to an ADC input signal. Refer to Table 5 “I/O Connectors and Pin Usage Table” for information about which port pins are connected to these features.

## 6.12 Touch Interface TWRPI/sLCD

The touch sensing input (TSI) module of the MKL46Z256 MCUs provides capacitive touch sensing detection with high sensitivity and enhanced robustness. Each TSI pin implements the capacitive measurement of an electrode. The TWR-KL46Z provides two methods for evaluating the TSI module. There are two electrodes on-board. Additionally, 12 TSI signals are connected to a Touch Tower Plug-in (TWRPI) socket (J2) that can accept Touch TWRPI daughter cards that may feature keypads, rotary dials, sliders, etc. Touch connector is also compatible with TWRPI-sLCD. Table 4 shows TWRPI/TWRPI-sLCD pin-out and corresponding connection to GD-6363P LCD.

**Table 4 Touch TWRPI socket pinout**

Pin	TWRPI	LCD_n	KL46	Module pin	Module signal
1	P5V_TRG_USB				
2	V_BRD				
3	Touch_TWRPI_1	LCD_P12	PTB16/TSIO_CH9/UART0_RX	<b>1</b>	<b>COM0</b>
4					
5	Touch_TWRPI_2	LCD_P13	PTB17/TSIO_CH10	<b>2</b>	<b>COM1</b>
6					
7	Touch_TWRPI_3	LCD_P14	PTB18/TSIO_CH11	<b>3</b>	<b>COM2</b>
8	Touch_TWRPI_4	LCD_P15	PTB19/TSIO_CH12	<b>4</b>	<b>COM3</b>
9	Touch_TWRPI_5	LCD_P23	PTC3/LLWU_P7/UART1_RX/FTM0_CH2/CLKOUT	<b>5</b>	<b>_3A</b>
10	Touch_TWRPI_6	LCD_P0	PTB0/ADC0_SE8/TSIO_CH0	<b>6</b>	<b>_S1</b>
11	Touch_TWRPI_7	LCD_P1	PTB1/ADC0_SE9/TSIO_CH6	<b>7</b>	<b>_3F</b>
12	Touch_TWRPI_8	LCD_P2	PTB2/ADC0_SE12/TSIO_CH7		
13	Touch_TWRPI_9	LCD_P3	PTB3/ADC0_SE13/TSIO_CH8	<b>8</b>	<b>_2A</b>
14	Touch_TWRPI_10	LCD_P20	PTC0/ADC0_SE14/TSIO_CH13	<b>9</b>	<b>_2F</b>
15	Touch_TWRPI_11	LCD_P22	PTC2/ADC0_SE11/TSIO_CH15/I2C1_SDA	<b>10</b>	<b>_1A</b>
16	Touch_TWRPI_12	LCD_P24	PTC4/LLWU_P8/UART1_TX/FTM0_CH3 {	<b>11</b>	<b>_1F</b>
17	Touch_TWRPI_ID0	LCD_P59	PTE20/ADC0_DP0/ADC0_SE0		
18	Touch_TWRPI_ID1	LCD_P60	PTE21/ADC0_DM0/ADC0_SE4A		
19	GND				
20	RST_TGT_MCU		RST_TGTMCU_B		



## 6.13 USB

The MKL46Z256 features a full-speed/low-speed USB module with OTG/Host/Device capability and built-in transceiver. The TWR-KL46Z routes the USB D+ and D- signals from the KL46Z256 MCU directly to the on-board USB connector (J5)

A power supply switch with an enable input signal and over-current flag output signal is used to supply power to the USB connector when the KL46Z256 is operating in host mode.

## 7 TWR-KL46Z Jumper options

The following is a list of all the jumper options. The default installed jumper settings are shown in bold.

**Note: Default Configuration, Board powered by OSJTAG USB, RTC powered by PWR\_MCU**

Jumper	Jumper designator	Signal	Jumper Option
V_BRD	J7	V_BRD	<b>DEF: 1-3 VBRD 3.3V</b> 1-5 VBRD 1.8V
	J28	VDDA_HDR	<b>DEF: 1-2 VDDA to MCU_PWR</b>
VREG IN SELECTOR	J3	VREG IN SELECTOR	<b>DEF: 1-2 Regulator powered by OpenSDA</b> 2-3 Regulator powered by TWR elevator
MCU_PWR	J27	MCU_PWR	<b>DEF: 1-2</b> You can use this jumper for Idd measurements

**Table 5 Connectors and Pin Usage**

Module	Jumper Designator	name	Options	Signal
USB	J20	KL46 USN ENA	DEF: 1-2	PTB11
	J21	KL46 USB FLGA	DEF: 1-2	PTE31
IRDA	SW3(6-3)	IRDAJ	OFF	PTE22/ADC0_DP3/ADC0_SE3/U ART2_TX
	SW3(5-4)	CMPO_IN0	OFF	PTE23/ADC0_DM3/ADC0_SE7A/ UART2_RX
Potentiometer	J22	Potentiometer Enable	DEF: 1-2	PTE29/ADC0_SE4B
Accelerometer	J26	SDA Accelerometer Enable	DEF: 1-2	PTC11/I2C1_SDA
	J24	SCL Accelerometer Enable	DEF: 1-2	PTC10/I2C1_SCL
	J23	ACCELEROMETER INT1	DEF: OPEN	PTC5/LLWU_P9/SPI0_SCK/CMPO _OUT
	J25	ACCELEROMETER INT2	DEF: OPEN	PTC6/LLWU_P10/EXTRG_IN/SPI 0_MISO
GPIO Header	J9-1			PTE20/ADC0_DP0/ADC0_SE0
	J9-2			PTE21/ADC0_DM0/ADC0_SE4A
	J9-3			PTA1/TSIO_CH2/UART0_RX
	J9-4			GND
	J9-5			SWD_DIO_TGTMCU
	J9-6			PTE31/FTM0_CH4
	J9-7			PTB9
	J9-8			PTA2/TSIO_CH3/UART0_TX
	J9-9			PTB11/SPI1_SCK
	J9-10			PTB10/SPI1_PCS0
	J9-11			PTC2/ADC0_SE11/TSIO_CH15/I2 C1_SDA
	J9-12			GND
	J9-13			PTC4/LLWU_P8/UART1_TX/FTM 0_CH3
	J9-14			PTC3/LLWU_P7/UART1_RX/FTM 0_CH2/CLKOUT {
	J9-15			PTC12/FTM_CLKIN0
	J9-16			PTC6/LLWU_P10/EXTRG_IN/SPI

Module	Jumper Designator	name	Options	Signal
				0_MISO
	J9-17			PTC16
	J9-18			PTC13/FTM_CLKIN1
	J9-19			GND
	J9-20			PTC17
<b>LEDs</b>	SW3(1-8)	Green LED	DEF: 1-2	PTA17
	SW3(2-7)	Red LED	DEF: 1-2	PTB8/EXTRG_IN
	J13	Orange LED	DEF: 1-2	PTE26/TPM0_CH5
	J15	Yellow LED	DEF: 1-2	PTA16
<b>Push Buttons</b>	SW4	Pushbutton1		PTA4
	SW2	Pushbutton2		PTC3/LLWU_P7/UART1_RX/FTM0_CH2/CLKOUT
<b>TSI Electrodes</b>	Elec1	Electrode1	TSIO_CH10	PTB16/TSIO_CH9
	Elec2	Electrode2	TSIO_CH9	PTB17/TSIO_CH10

## 8 Useful links

- ▶ <http://www.freescale.com/TWR-KL46Z>
- ▶ [www.freescale.com](http://www.freescale.com)
- ▶ [www.iar.com/freescale](http://www.iar.com/freescale)
- ▶ [www.pemicro.com](http://www.pemicro.com)
- ▶ [www.freescale.com/codewarrior](http://www.freescale.com/codewarrior)
  - CodeWarrior MCUv10.4
- ▶ [www.segger.com](http://www.segger.com)

### Revision History

Revision	Date	Description
1.0	June, 2013	Initial release for PWA 700-27760 A draft
1.1	July, 2013	Update for board Rev C