

# XU2N18NP341

photo-electric sensor - XU2 - thru beam - Sn  
15m - 12..24VDC - cable 2m

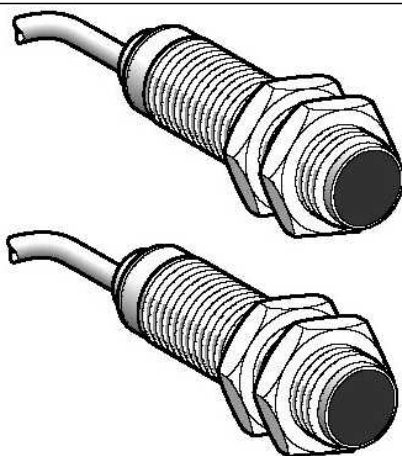

## Main

Range of product	OsiSense XU
Series name	Application food and beverage
Electronic sensor type	Photo-electric sensor
Sensor name	XU2
Sensor design	Cylindrical M18
Detection system	Thru beam
Material	Stainless steel
Line of sight type	Axial
Type of output signal	Discrete
Supply circuit type	DC
Wiring technique	3-wire
Discrete output type	NPN
Discrete output function	1 NO or 1 NC programmable
Electrical connection	Cable
Cable length	2 m
Product specific application	-
Emission	Infrared thru beam
[Sn] nominal sensing distance	15 m thru beam

## Buy online

### Complementary

Enclosure material	Stainless steel : 304 CU
Lens material	PMMA
Maximum sensing distance	20 m
Output type	Solid state
Add on output	Without
Add on input	Breaking test + programming
Cable composition	4 x 0.34 mm <sup>2</sup>
Wire insulation material	PvR
Cable outer diameter	4.2 mm
Status LED	1 LED (green) for supply on 1 LED (yellow) for output state
[Us] rated supply voltage	12...24 V DC with reverse polarity protection
Supply voltage limits	10...30 V DC
Switching capacity in mA	<= 100 mA (overload and short-circuit protection)
Switching frequency	<= 500 Hz
Voltage drop	<= 1.5 V (closed state)
Current consumption	<= 50 mA (no-load)
Delay first up	<= 15 ms
Delay response	<= 1 ms
Delay recovery	<= 1 ms
Setting-up	Without sensitivity adjustment
Diameter	18 mm
Length	62 mm
Product weight	0.27 kg
Kit composition	Transmitter + receiver

## Environment

Product certifications	CE CSA UL
Ambient air temperature for operation	-25...55 °C
Ambient air temperature for storage	-40...70 °C
Vibration resistance	25 gn, amplitude = +/- 1.5 mm (f = 10...55 Hz) conforming to IEC 60068-2-6
Shock resistance	30 gn (duration = 11 ms) conforming to IEC 60068-2-27
IP degree of protection	IP67 conforming to IEC 60529

## Offer Sustainability

Sustainable offer status	Not Green Premium product
RoHS (date code: YYWW)	Will be compliant on 3Q2013
Product environmental profile	Available <a href="#">Product Environmental</a>
Product end of life instructions	Available <a href="#">End Of Life Manual</a>

## Contractual warranty

Warranty period	18 months
-----------------	-----------

Dimensions

Transmitter's Dimensions

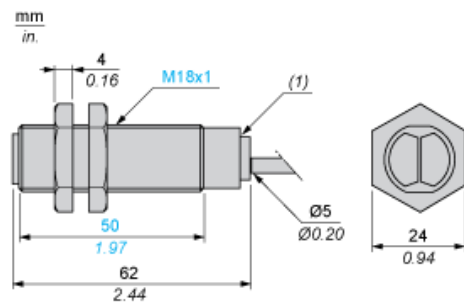

(1) LED

Receiver's Dimensions

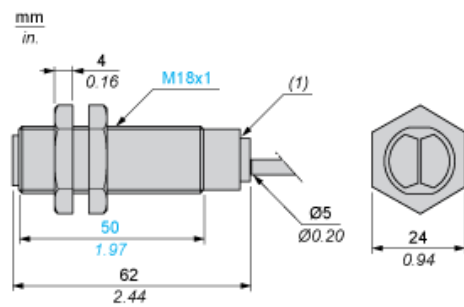

(1) LED

---

Mounting and Clearance

---

Fixing nut tightening torque: < 15 N.m

Connector tightening torque: 2 N.m

Wiring Schemes

Transmitter

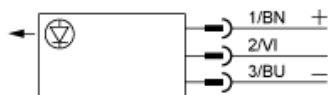

BN : Brown  
VI : Violet (beam break input)  
BU : Blue

3-wire, NPN NO or NC Programmable Function

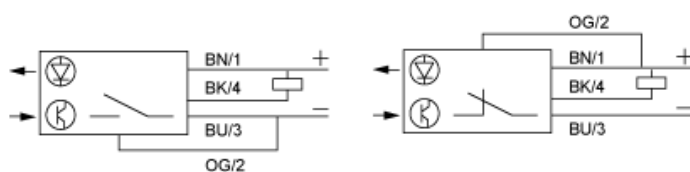

BN : Brown  
BK : Black (out / output)  
BU : Blue  
OG : Orange (program)

Wiring Schemes

Beam Break Input on Thru-beam Transmitter

Beam made

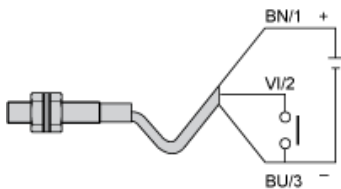

BN : Brown  
VI : Violet (beam break input)  
BU : Blue

Beam broken

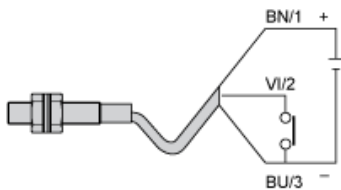

BN : Brown  
VI : Violet (beam break input)  
BU : Blue

Detection Curves

Thru-beam System

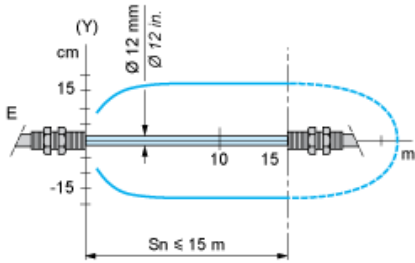

(y)  $\varnothing$  of beam

Excess Gain Curves (Ambient Temperature: + 25° C)

Thru-beam System

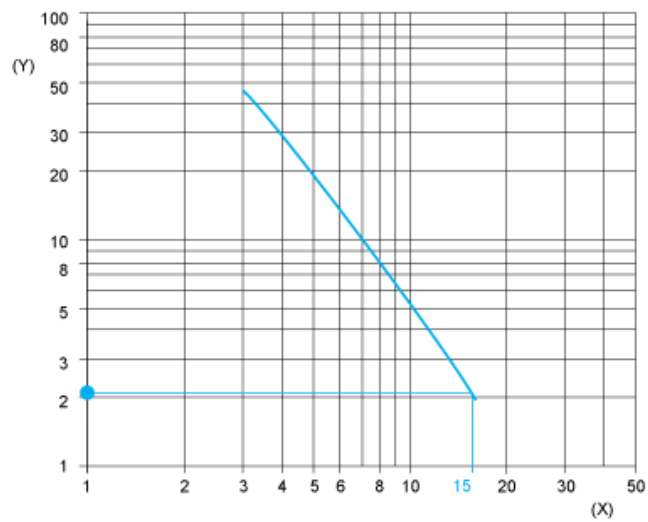

(y) Gain  
(x) Distance (m)