

Schottky Barrier Rectifier



Features:

- Metal of silicon rectifier, majority carrier conduction
- Guard ring for transient protection
- Low power loss, high efficiency
- High current capability, low VF
- High surge capacity
- Plastic package has UL flammability classification 94V-0
- For use in low voltage, high frequency inverters, free wheeling, and polarity protection applications

Mechanical Data:

Case	: TO-220AC molded plastic
Polarity	: As marked on the body
Weight	: 0.08 ounces, 2.24 grams
Mounting Position	: Any
Reverse Voltage	: 60 Volts
Forward Current	: 10 Amperes

Maximum Ratings and Electrical Characteristics:

Rating at 25°C ambient temperature unless otherwise specified.

Single phase, half wave, 60Hz, resistive or inductive load.

For capacitive load, derate current by 20%.

Characteristics	Symbol	Values	Unit
Max. Recurrent Peak Reverse Voltage	V_{RRM}	60	V
Max. RMS Voltage	V_{RMS}	42	
Max. DC Blocking Voltage	V_{DC}	60	
Max. Average Forward Rectified Current (See Fig.1)	$I_{(AV)}$	10	A
Peak Forward Surge Current 8.3ms Single Half Sine-Wave Super Imposed on Rated Load (JEDEC Method)	I_{FSM}	150	
Peak Forward Voltage (Note1) $I_F=10A @T_J=25^{\circ}C$ $I_F=10A @T_J=125^{\circ}C$ $I_F=20A @T_J=25^{\circ}C$ $I_F=20A @T_J=125^{\circ}C$	V_F	0.8 0.7 0.95 0.85	V
Max. DC Reverse Current at Rated DC Blocking Voltage at $T_A = 25^{\circ}C$ $T_A = 125^{\circ}C$	I_R	0.1 10	mA
Typical Junction Capacitance (Note 2)	C_J	400	pF
Typical Thermal Resistance (Note 3)	$R_{\theta JC}$	2.5	°C/W
Operating Temperature Range	T_J	-55 to +150	°C
Storage Temperature Range	T_{STG}	-55 to +175	°C

Notes:

1. 300µs pulse width, 2% duty cycle.
2. Measured at 1.0MHz and applied reverse voltage of 4.0V DC.
3. Thermal resistance junction to case
4. The typical data above is for reference only

Ratings and Characteristic Curves

FIG. 1 – FORWARD CURRENT DERATING CURVE

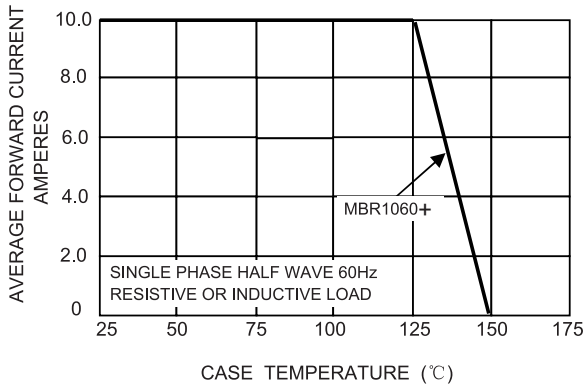

FIG. 2 – MAXIMUM NON-REPETITIVE SURGE CURRENT

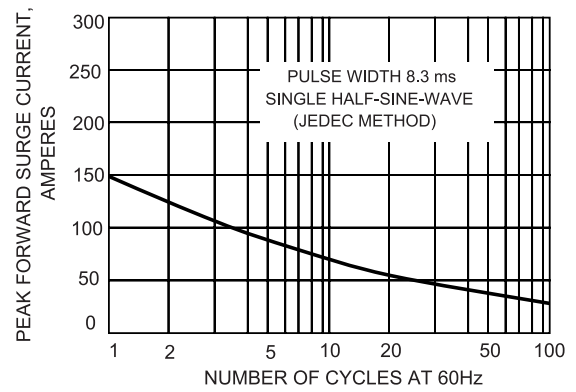

FIG.3-TYPICAL REVERSE

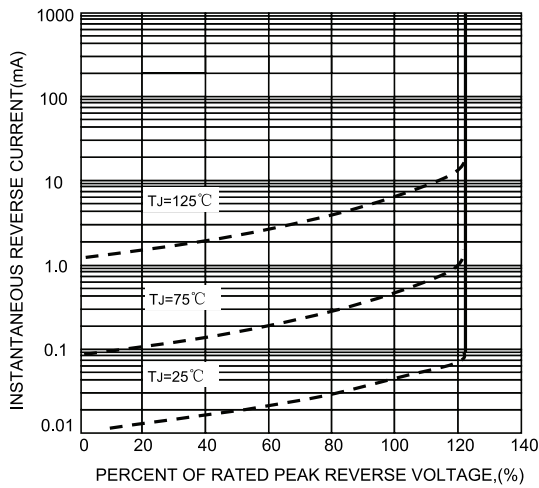

FIG.4-TYPICAL FORWARD CHARACTERISTICS

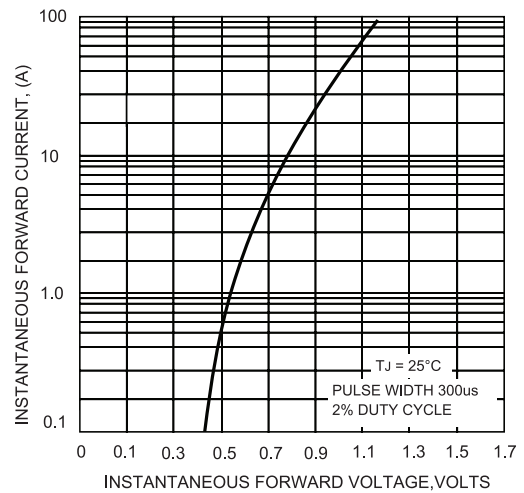
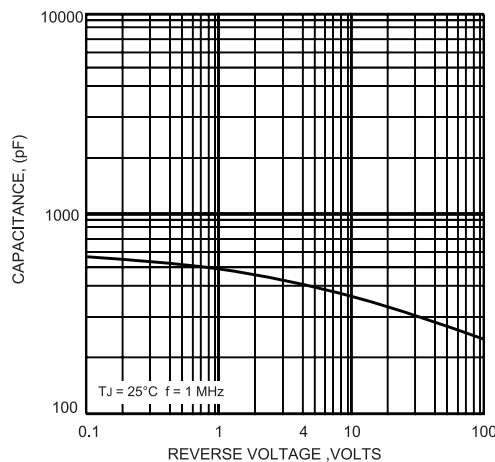
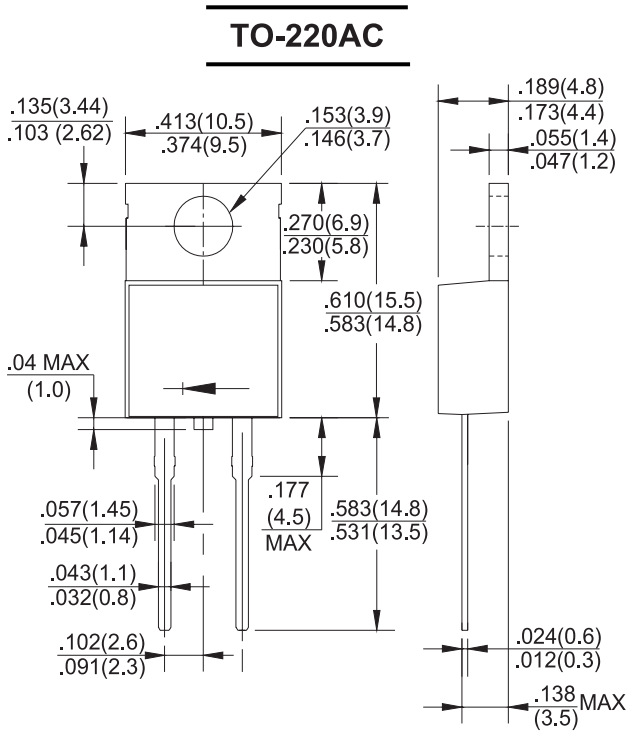

FIG.5 – TYPICAL JUNCTION CAPACITANCE



Schottky Barrier Rectifier

Dimensions:



Dimensions : Inches (Millimetres)

Part Number Table

Description	Part Number
Schottky Barrier Rectifiers	MBR1060+

Important Notice : This data sheet and its contents (the "Information") belong to the members of the Premier Farnell group of companies (the "Group") or are licensed to it. No licence is granted for the use of it other than for information purposes in connection with the products to which it relates. No licence of any intellectual property rights is granted. The Information is subject to change without notice and replaces all data sheets previously supplied. The Information supplied is believed to be accurate but the Group assumes no responsibility for its accuracy or completeness, any error in or omission from it or for any use made of it. Users of this data sheet should check for themselves the Information and the suitability of the products for their purpose and not make any assumptions based on information included or omitted. Liability for loss or damage resulting from any reliance on the Information or use of it (including liability resulting from negligence or where the Group was aware of the possibility of such loss or damage arising) is excluded. This will not operate to limit or restrict the Group's liability for death or personal injury resulting from its negligence. Multicomp is the registered trademark of the Group. © Premier Farnell Limited 2016.

www.element14.com
www.farnell.com
www.newark.com

