

KEMET Part Number: SS17HB-R13020
(UAL17HBR130200)

Commercial Grade, SS17HB, 2000 uH

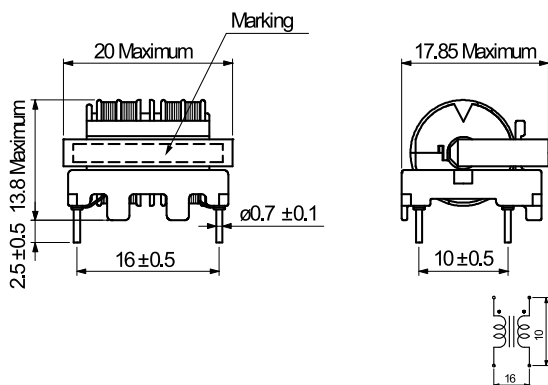

Dimensions

L	20mm MAX
T	17.85mm MAX
H	13.8mm MAX
S	10mm +/-0.5mm
S1	16mm +/-0.5mm
LL	2.5mm +/-0.5mm
F	0.7mm +/-0.1mm
Wire Size	0.4mm

Packaging Specifications

Weight:	6.2 g
----------------	-------

General Information

Style:	Through-Hole Choke
Series:	SS17HB
Description:	Common Mode Filter
RoHS:	Yes
Miscellaneous:	Inductance Measurement Condition: 1kHz 1V KC530 or equivalent

Specifications

Inductance:	2000 uH
Rated Temperature:	120C
Current:	1.3 Amps
Voltage AC:	250 VAC
DC Resistance:	180 mOhms