

CUSTOMER	MCM	FILE NO.	50-080
----------	-----	----------	--------

This drawing and specifications herein are the confidential property of MCM Electronics and shall not be reproduced, copied or disclosed in whole or in part without written permission.

REV.	DESCRIPTION	DRAWN / DATE	APPROVED / DATE
0	INITIAL RELEASE	FROS 10/03/2007	

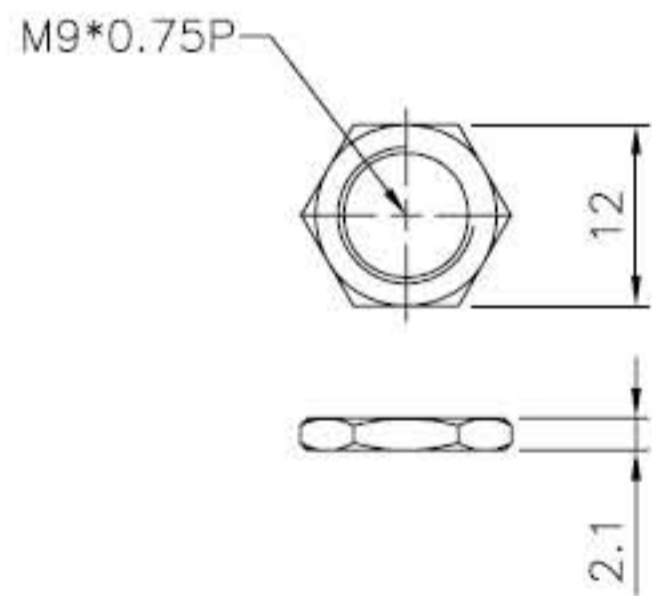
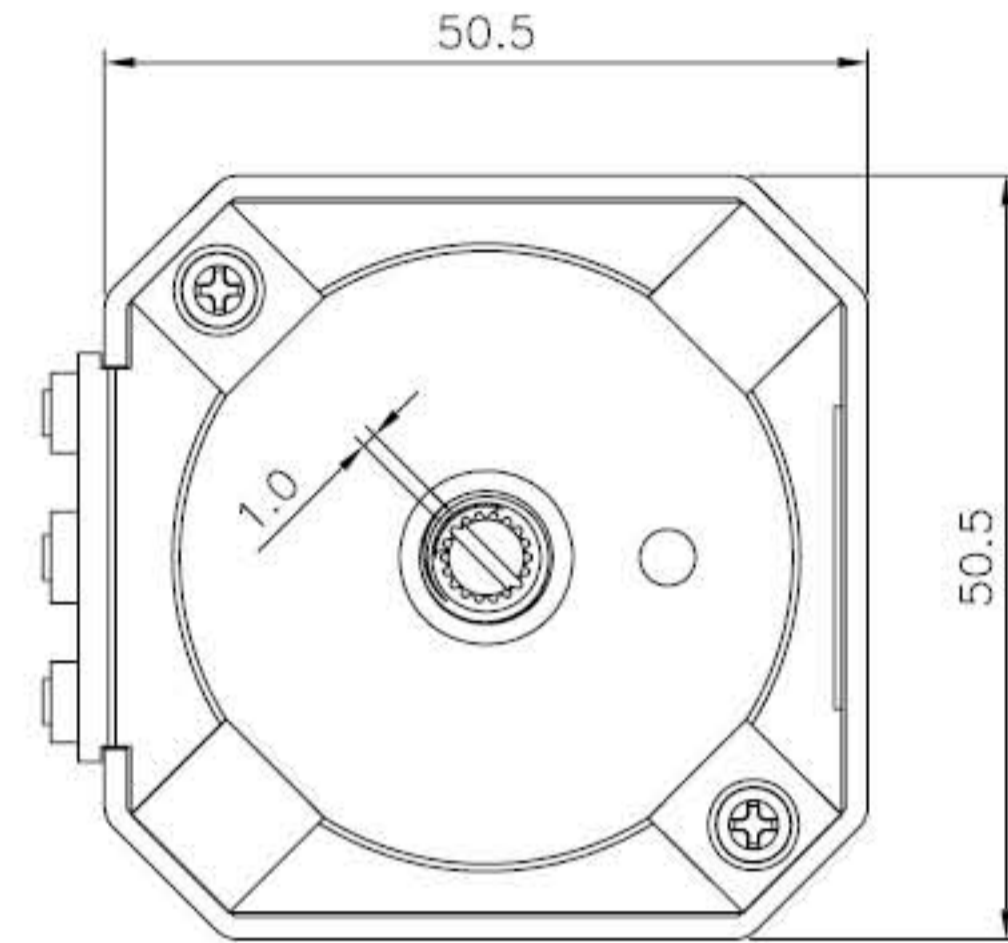
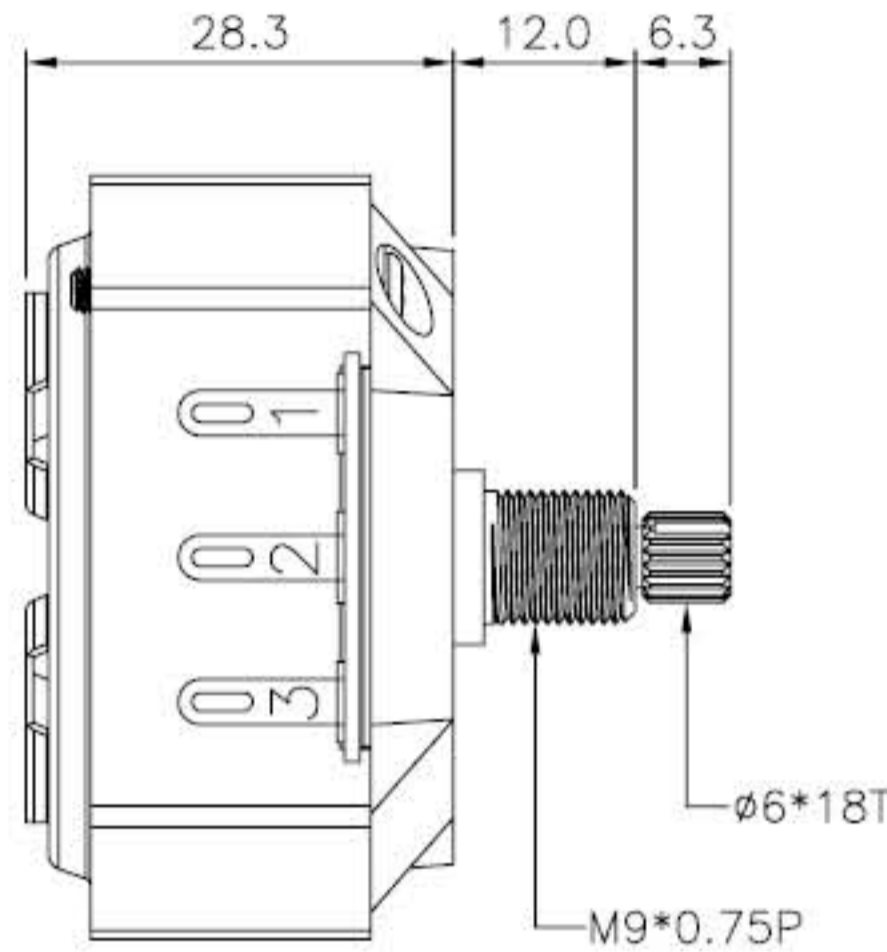
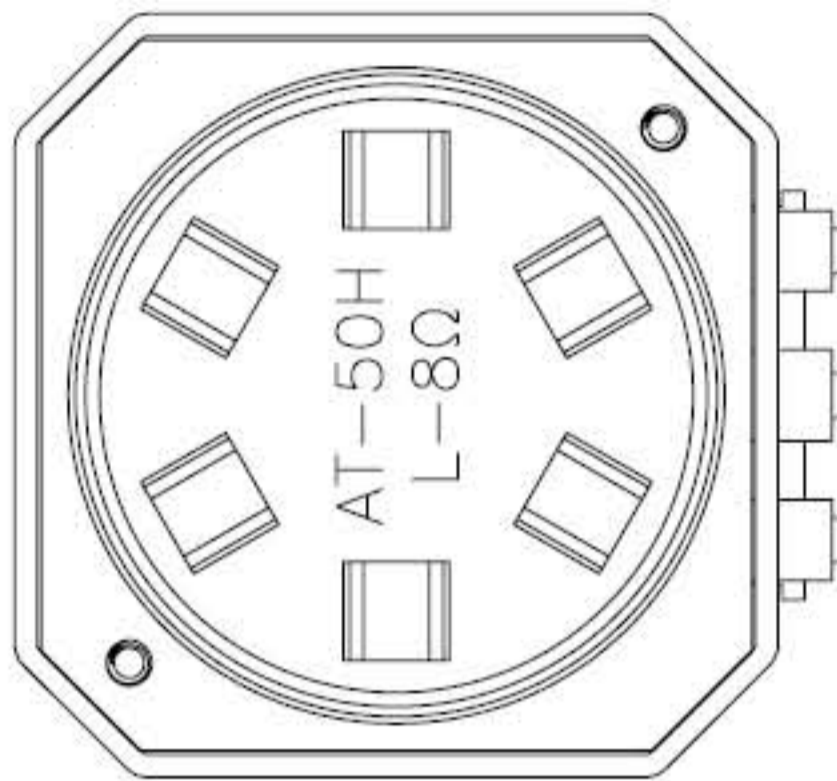

NUT 2PCS

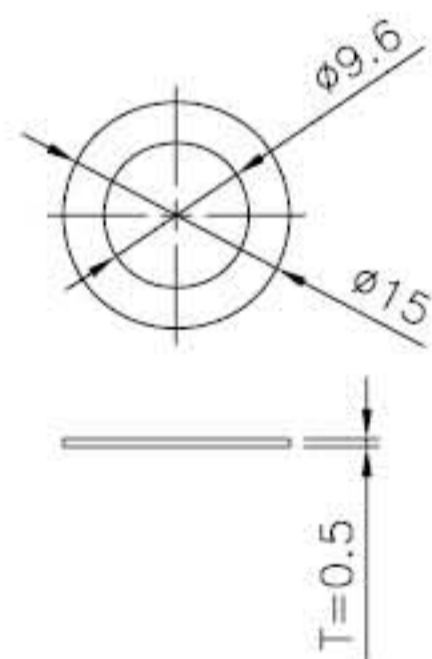

WASHER

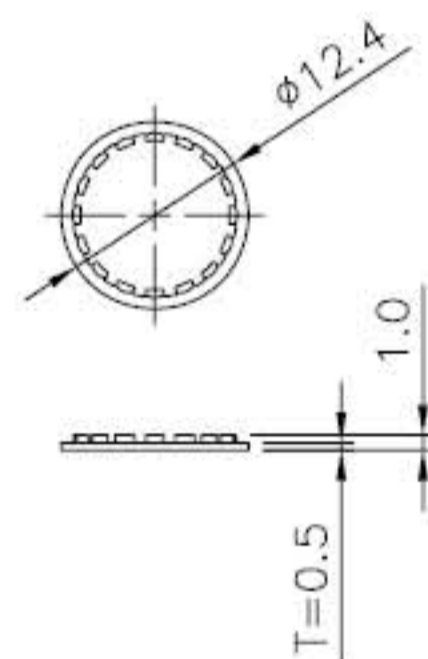

WASHER

SPECIFICATION:

1. PLASTIC BODY: BAKELITE, BLACK
2. FRONT METAL PLATE (SHAFT SIDE): ZINC
3. BACK METAL PLATE: STEEL, CHROMIUM-PLATED
4. THREAD BUSHING: BRASS
5. SHAFT: ALUMINUM
6. SOLDER TERMINALS: BRASS, TIN-PLATED
7. NUTS AND WASHERS: STEEL, NICKEL-PLATED

DIMENSIONS ARE IN mm [INCH]	TOLERANCES ARE FRACTIONS DECIMALS ANGLES	MATERIAL	MCM Electronics www.mcmelectronics.com	50W MONO L-PAD	P/N	50-080	DRAWN	FROS	DATE	10/03/2007	
MOLD NO.	.x ± 0.20 [0.008] .xx ± 0.12 [0.005]	FINISH			PROJECT NO.						
50-080		COLOR			SCALE	1/1	SIZE	A4	SHEET	1	OF