



Main

Range of product	Modicon TM3
Product or component type	Discrete output module
Range compatibility	Modicon M241 Modicon M221 Modicon M251
Discrete output type	Transistor
Discrete output number	16
Discrete output logic	Positive logic (source)
Discrete output voltage	24 V DC for transistor output
Discrete output current	500 mA for transistor output

Complementary

Discrete I/O number	16
Current consumption	5 mA at 5 V DC via bus connector at state off 0 mA at 24 V DC via bus connector at state off 15 mA at 5 V DC via bus connector at state on 20 mA at 24 V DC via bus connector at state on
Response time	450 µs for turn-on 450 µs for turn-off
Leakage current	0.1 mA for transistor output
Voltage drop	0.4 V
Tungsten load	3 W for transistor output
Local signalling	Green for output status
Electrical connection	Removable screw terminal block pitch 3.81 mm with 10 terminal(s) of 1.5 mm ² connection capacity for outputs
Cable length	<= 30 m unshielded cable for transistor output
Insulation	Non-insulated between outputs AC between output and internal logic
Marking	CE
Mounting support	Top hat type TH35-15 rail conforming to IEC 60715 Top hat type TH35-7.5 rail conforming to IEC 60715

Disclaimer: This documentation is not intended as a substitute for and is not to be used for determining suitability or reliability of these products for specific user applications

	Plate or panel with fixing kit
Height	90 mm
Depth	84.6 mm
Width	27.4 mm
Product weight	0.11 kg

Environment

Standards	EN/IEC 61131-2 EN/IEC 61010-2-201
Product certifications	CULus C-Tick
Resistance to electrostatic discharge	4 kV (on contact) conforming to EN/IEC 61000-4-2 8 kV (in air) conforming to EN/IEC 61000-4-2
Resistance to electromagnetic fields	10 V/m at 80 MHz...1 GHz conforming to EN/IEC 61000-4-3 3 V/m at 1.4 GHz...2 GHz conforming to EN/IEC 61000-4-3 1 V/m at 2 GHz...3 GHz conforming to EN/IEC 61000-4-3
Resistance to magnetic fields	30 A/m at 50...60 Hz conforming to EN/IEC 61000-4-8
Resistance to fast transients	1 kV for I/O conforming to EN/IEC 61000-4-4
Surge withstand	1 kV for I/O (DC) in common mode conforming to EN/IEC 61000-4-5
Resistance to conducted disturbances, induced by radio frequency fields	10 Vrms at 0.15...80 MHz conforming to EN/IEC 61000-4-6 3 Vrms at spot frequency (2, 3, 4, 6.2, 8.2, 12.6, 16.5, 18.8, 22, 25 MHz) conforming to Marine specification (LR, ABS, DNV, GL)
Electromagnetic emission	Radiated emissions, test level: 40 dB μ V/m QP with class A, condition of test: 10 m (radio frequency: 30...230 MHz) conforming to EN/IEC 55011 Radiated emissions, test level: 47 dB μ V/m QP with class A, condition of test: 10 m (radio frequency: 230 MHz...1 GHz) conforming to EN/IEC 55011
Ambient air temperature for operation	-10...55 °C for horizontal installation -10...35 °C for vertical installation
Ambient air temperature for storage	-25...70 °C
Relative humidity	10...95 % without condensation in operation 10...95 % without condensation in storage
IP degree of protection	IP20 with protective cover in place
Pollution degree	2
Operating altitude	0...2000 m
Storage altitude	0...3000 m
Vibration resistance	3.5 mm (vibration frequency: 5...8.4 Hz) on DIN rail 3 gn (vibration frequency: 8.4...150 Hz) on DIN rail 3.5 mm (vibration frequency: 5...8.4 Hz) on panel 3 gn (vibration frequency: 8.4...150 Hz) on panel
Shock resistance	15 gn (test wave duration:11 ms)

Offer Sustainability

Sustainable offer status	Green Premium product
RoHS (date code: YYWW)	Compliant - since 1348 - Schneider Electric declaration of conformity Schneider Electric declaration of conformity
REACH	Reference not containing SVHC above the threshold Reference not containing SVHC above the threshold
Product environmental profile	Available Product environmental
Product end of life instructions	Available End of life manual

Dimensions

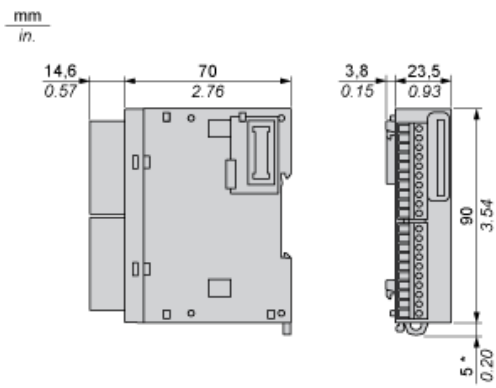

(*) 8.5 mm/0.33 in. when the clamp is pulled out.

Spacing Requirements

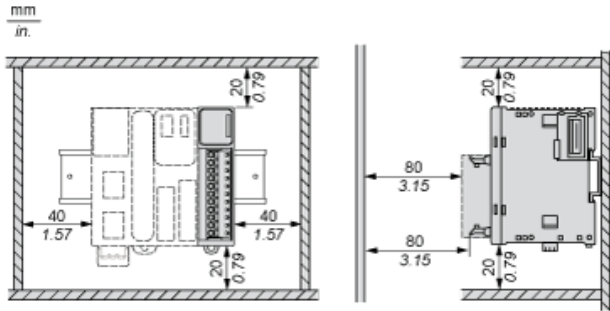

Mounting on a Rail

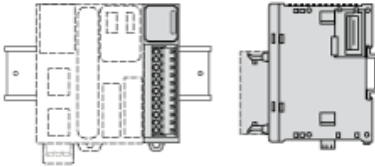

Incorrect Mounting

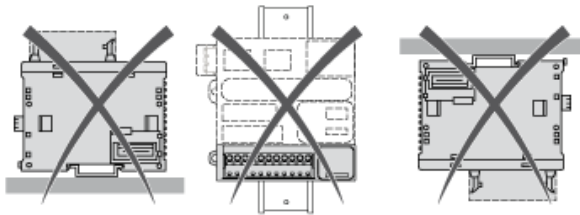

Mounting on a Panel Surface

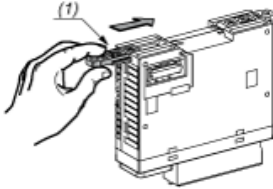

(1) Install a mounting strip

Mounting Hole Layout

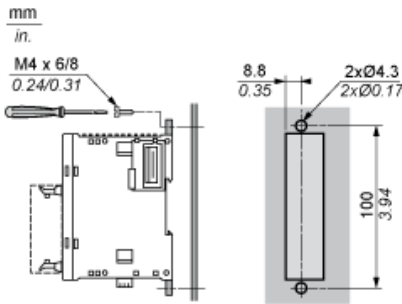

Digital Transistor Output Module (16-Channel, Source)

Wiring Diagram

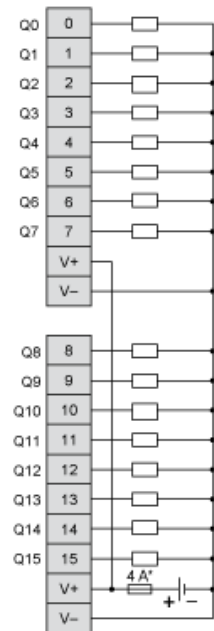

(*) Type T fuse