



Main

Range of product	Zelio Time
Product or component type	Electronic timing relay
Electrical connection	Plug-in sub-base 11
Discrete output type	Relay
Contacts type and composition	2 C/O timed contacts AgNi (cadmium free)
Component name	RE48A
Time delay type	C B Di A
Time delay range	0.05...3 s 0.5...30 s 5...300 s 0.2...12 s 0.5...30 min 2...120 h 2...120 s 5...300 min 0.02...1.2 s 5...300 h 0.5...30 h 2...120 min 0.2...12 h 0.2...12 min
[Us] rated supply voltage	24...240 V AC/DC 50/60 Hz
Voltage range	0.85...1.1 Us AC 0.9...1.1 Us DC
[In] rated current	5 A

Complementary

Product front plate size	48 x 48 mm
Control type	Selector switch front panel

Housing material	Self-extinguishing
Repeat accuracy	+/- 0.2 % of the maximum setting value IEC 61812-1
Temperature drift	+/- 0.02 %/°C of the maximum setting value IEC 61812-1
Voltage drift	+/- 0.2 %/V of the maximum setting value 48...240 V +/- 1 %/V of the maximum setting value 24...48 V
Setting accuracy of time delay	+/- 5 % of full scale 25 °C IEC 61812-1
Minimum pulse duration	20 ms
Reset time	>= 25 ms on de-energisation
Pick up duration	55 ms
On-load factor	100 %
Power consumption in VA	1.1 VA 24 V 4.8 VA 240 V
Power consumption in W	0.5 W 24 V 1.7 W 240 V
Breaking capacity	1250 VA
Minimum switching current	100 mA
Maximum switching current	5 A
Maximum switching voltage	250 V AC/DC
Electrical durability	100000 cycles
Mechanical durability	30000000 cycles
Output voltage	240 V 5 A AC-12 30 V 2 A DC-13 240 V 1.5 A AC-15
Marking	CE
Surge withstand	1 kV differential mode IEC 61000-4-5 level 3 2 kV common mode IEC 61000-4-5 level 3
Mounting support	Base mounted: socket Panel mounted: system supplied with the product
Local signalling	1 LED yellow output relay state LED indicator green flashing: relay energised timing in progress LED indicator green on steady: relay energised, no timing in progress
Product weight	0.14 kg
Functionality	Multifunction
Compatibility code	RE48

Environment

Humidity drift	+/- 0.05 %/%RH of the maximum setting value IEC 61812-1
Immunity to microbreaks	< 10 ms
Dielectric strength	1 kV 1 mA/1 minute IEC 61812-1
Protection against electric shocks	4 kV category 3 IEC 60664-1 4 kV category 3 IEC 61812-1
Standards	IEC 61812-1 IEC 60669-2-3 73/23/EEC EN 50082-1/2 93/68/EEC 89/336/EEC EN 50081-1/2
Product certifications	GL cULus C-Tick CSA UL
Ambient air temperature for storage	-40...70 °C
Ambient air temperature for operation	-20...50 °C
IP degree of protection	IP50 front face IEC 60529 IP40 housing IEC 60529
Vibration resistance	0.35 mm 10...55 Hz IEC 60068-2-6
Relative humidity	93 % without condensation IEC 60068-2-3

Resistance to electrostatic discharge	6 kV in contact EN/IEC 61000-4-2 level 3 8 kV in air EN/IEC 61000-4-2 level 3
Resistance to electromagnetic fields	10 V/m 26 MHz to 1 GHz IEC 61000-4-3 level 3
Resistance to fast transients	2 kV capacitive connecting clip EN/IEC 61000-4-4 level 4 4 kV direct EN/IEC 61000-4-4 level 4
Immunity to radioelectric fields	10 V 0.15...80 MHz EN/IEC 61000-4-6 level 3
Immunity to voltage dips	30 % 10 ms EN/IEC 61000-4-11 60 % 100 ms EN/IEC 61000-4-11 95 % 5 s EN/IEC 61000-4-11
Disturbance radiated/conducted	Class B 0.15...30 MHz EN 55022 (EN 55011 group 1)

Contractual warranty

Warranty period	18 months
-----------------	-----------

Function A : Power on Delay Relay

Description

The timing period T begins on energisation. After timing, the output R closes.

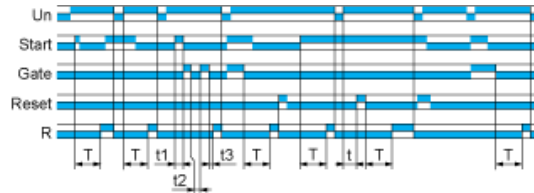

$$T = t1 + t2 + t3$$

Function B : Interval Relay with Control Signal

Description

After power-up, pulsing or maintaining control contact C starts the timing T. The output R closes for the duration of the timing period T then reverts to its initial

$$T = t1 + t2 + t3$$

Function C : Off-Delay Relay with Control Signal

Description

After power-up and closing of the control contact, the output closes. When control contact re-opens, timing T starts. At the end of the timing period, the output re-

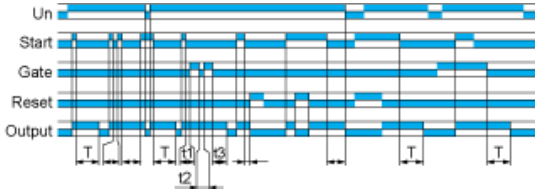

$T = t1 + t2 + t3$

Function Di : Symmetrical Flasher Relay (Starting Pulse On)

Description

Repetitive cycle with two timing periods T of equal duration, with output changing state at the end of each timing period T .

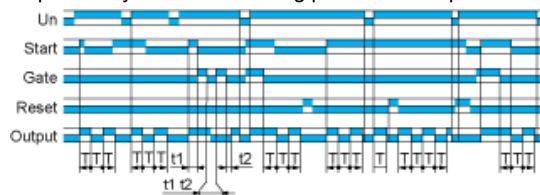

Legend

Relay de-energised

Relay energised

Output open

Output closed

C Control contact

G Gate

R Relay or solid state output

R1/R2 2 timed outputs

R2 inst. The second output is instantaneous if the right position is selected

T Timing period

Ta Adjustable On-delay

Tr Adjustable Off-delay

U Supply

Width 48 mm

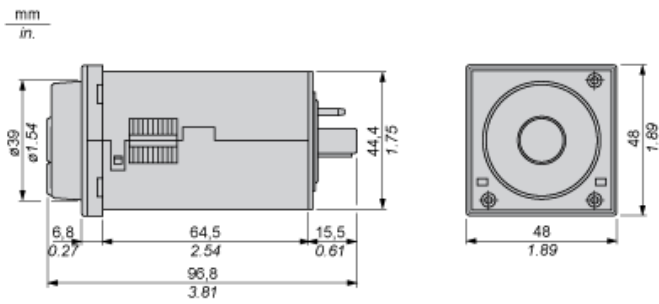

Panel Cut-Out and Mounting

Panel Cut-Out

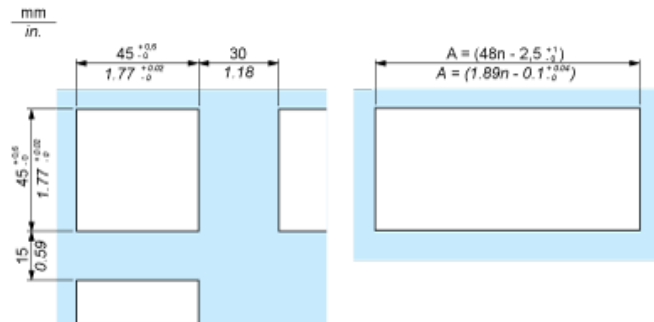

n Number of devices mounted side-by-side

Mounting

Cover positioning and mounting

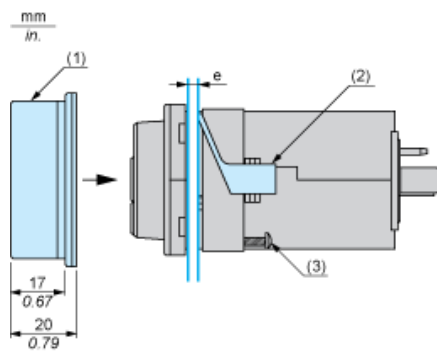

- e Panel thickness
- 1 Protective cover
- 2 Panel mounting frame
- 3 Locating screw

Wiring Diagram

