



310 8879

# Color Mark Sensor

# E3M-V

- Detects laminated or light-dispersing objects in stable operation without being influenced by mirror reflection.
- Double indication of the detection level and threshold level allows easy grasp of the operating status and easy adjustment.
- Automatically sets to the optimum threshold level while sensing objects are being conveyed and incorporates an auto-teaching function that discriminates between the mark and background and turns ON when the mark is detected.
- IP67 watertight construction with M12 rotary connector
- High response speed of 50  $\mu$ s and half the size of OMRON's conventional models.



## Ordering Information

Green light

Shape	Connection method	Sensing distance	Spot diameter	Model	
				NPN output	PNP output
	Connector type (see note)	10 $\pm$ 3 mm	1 x 4 mm	E3M-VG11	E3M-VG16
			4 x 1 mm	E3M-VG21	E3M-VG26

Note: Possible to switch between vertical or horizontal connection using the M12 rotary connector.

### Accessories (Order Separately)

#### Mounting Brackets

Shape	Model	Quantity	Remarks
	E39-L131	1	
	E39-L132	1	For rear mounting

#### Sensor I/O Connectors

Shape	Type	Cable type		Model
	Single-end connector (Straight)	2 m	4-wire cable	XS2F-D421-D80-A
		5 m		XS2F-D421-G80-A
	Single-end connector (L-shaped)	2 m		XS2F-D422-D80-A
		5 m		XS2F-D422-G80-A

Note: For details, refer to the *Sensor I/O Connectors Catalog (X065)*.

E3M-V

OMRON

E3M-V

# Specifications

## ▣ Ratings/Characteristics

Item	E3M-VG11	E3M-VG21	E3M-VG16	E3M-VG26
<b>Sensing distance</b>	10±3 mm			
<b>Spot size (W x H)</b>	1 x 4 mm	4 x 1 mm	1 x 4 mm	4 x 1 mm
<b>Light source (wavelength)</b>	Green LED (525 nm)			
<b>Power supply voltage</b>	10 to 30 VDC, ripple (p-p) 10% max.			
<b>Current consumption</b>	100 mA max.			
<b>Control output</b>	Load power supply voltage: 30 VDC max. Load current: 100 mA max. (Residual voltage: 1.2 V max.) NPN open collector output type		Load power supply voltage: 30 VDC max. Load current: 100 mA max. (Residual voltage: 2 V max.) PNP open collector output type	
<b>Remote control input (see note 1)</b>	ON: Short-circuited to 0 or 1.5 V max. (with a flow current of 1 mA max.) OFF: Open or V <sub>CC</sub> -1.5 V to V <sub>CC</sub> (with a leakage current of 0.1 mA max.)		ON: V <sub>CC</sub> -1.5 V to V <sub>CC</sub> (with an absorption current of 3 mA max.) OFF: Open or 1.5 V max. (with a leakage current of 0.1 mA max.)	
<b>Remote control output (see note 1)</b>	Load power supply voltage: 30 VDC max. Load current: 100 mA max. (Residual voltage: 1.2 V max.) NPN open collector output type		Load power supply voltage: 30 VDC max. Load current: 100 mA max. (Residual voltage: 2 V max.) PNP open collector output type	
<b>Bank selection</b>	Two banks selectable. Available for remote control only. (Refer to <i>Remote Control Function</i> .)			
<b>Circuit protection</b>	Protection from reversed power supply connection and load short-circuit			
<b>Response time</b>	ON: 50 μs max. OFF: 70 μs max.			
<b>Ambient illumination (on receiver lens)</b>	Incandescent lamp: 3,000 lx max. Sunlight: 10,000 lx max.			
<b>Ambient temperature</b>	Operating: -20°C to 55°C/Storage: -30°C to 70°C (with no icing)			
<b>Ambient humidity</b>	Operating: 35% to 85%/Storage: 35% to 95°C (with no condensation)			
<b>Insulation resistance</b>	20 MΩ min. (at 500 VDC)			
<b>Dielectric strength</b>	1,000 VAC, 50/60Hz, 1 min.			
<b>Vibration resistance (see note 2)</b>	Destruction: 10 to 55 Hz, 1-mm double amplitude or 150 m/s <sup>2</sup> for 2 hrs each in X, Y, and Z directions			
<b>Shock resistance (see note 3)</b>	Destruction: 500 m/s <sup>2</sup> 3 times each in X, Y, and Z directions			
<b>Degree of protection</b>	IEC60529 IP67 (with protective cover)			
<b>Connection method</b>	Connector			
<b>Weight with package box</b>	Approx. 100 g			
<b>Material</b>	Case: Polybutylene terephthalate Lens: Acrylic (PMMA)			
<b>Others</b>	Instruction manual			

- Note: 1. Remote control input and answer-back output share the same signal line.  
 2. The Sensor withstands 0.75-mm double amplitude or 100 m/s<sup>2</sup> if the mounting bracket is attached to the Sensor.  
 3. The Sensor withstands 300 m/s<sup>2</sup> if the mounting bracket is attached to the Sensor.

# Engineering Data

## Sensing Distance vs. Incident Characteristics (Typical)

E3M-VG1□

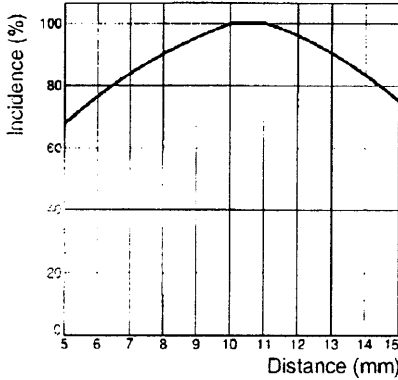

## Angle vs. Incident Characteristics (X Direction)

E3M-VG1□/VG2□

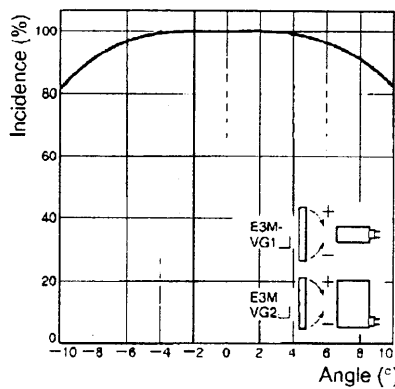

## Angle vs. Incident Characteristics (Y Direction)

E3M-VG1□/VG2□

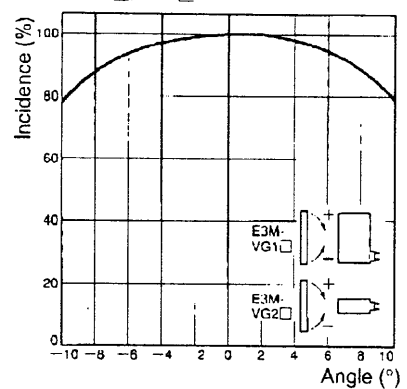

## Color Sensing Capacity

E3M-VG□□

	White	Red	Yellow red	Yellow	Yellow green	Green	Blue green	Blue	Purple	Red purple	Black
White	○	○	○	○	○	○	○	○	○	○	○
Red	○	○	○	○	○	○	○	○	○	○	○
Yellow red	○	○	○	○	○	○	○	○	○	○	○
Yellow	○	○	○	○	○	○	○	○	○	○	○
Green yellow	○	○	○	○	○	○	○	○	○	○	○
Green	○	○	○	○	○	○	○	○	○	○	○
Blue green	○	○	○	○	○	○	○	○	○	○	○
Blue	○	○	○	○	○	○	○	○	○	○	○
Purple	○	○	○	○	○	○	○	○	○	○	○
Red purple	○	○	○	○	○	○	○	○	○	○	○
Black	○	○	○	○	○	○	○	○	○	○	○

○: Detectable    △: Detectable but unstable    X: Not detectable

## Differences in Incident by Color

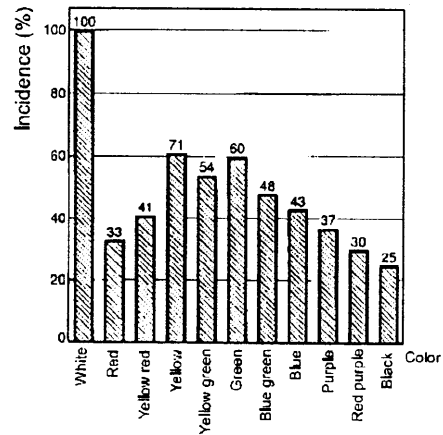

## Standard Sensing Object (Color vs. Munsell)

Japan Color Enterprise's Standard Color Card 230

11 standard colors	Munsell color notation
White	N9.5
Red	4R, 4.5/12.0
Yellow red	4YR, 6.0/11.5
Yellow	5Y, 8.5/11.0
Yellow green	3GY, 6.5/10.0
Green	3G, 6.5/9.0
Blue green	5BG, 4.5/10.0
Blue	3PB, 5.0/10.0
Purple	7P, 5.0/10.0
Red purple	6RP, 4.5/12.5
Black	N2.0

## Technical Guide

### Glossy Sensing Objects

Incline the Sensor to detect glossy objects so that the Sensor will not be influenced by the mirror reflection of light and to ensure the stable sensing operation of the E3M-V.

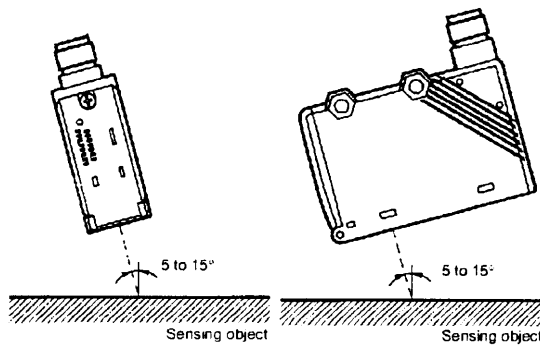

E3M-V ————— OMRON ————— E3M-V

Nomenclature

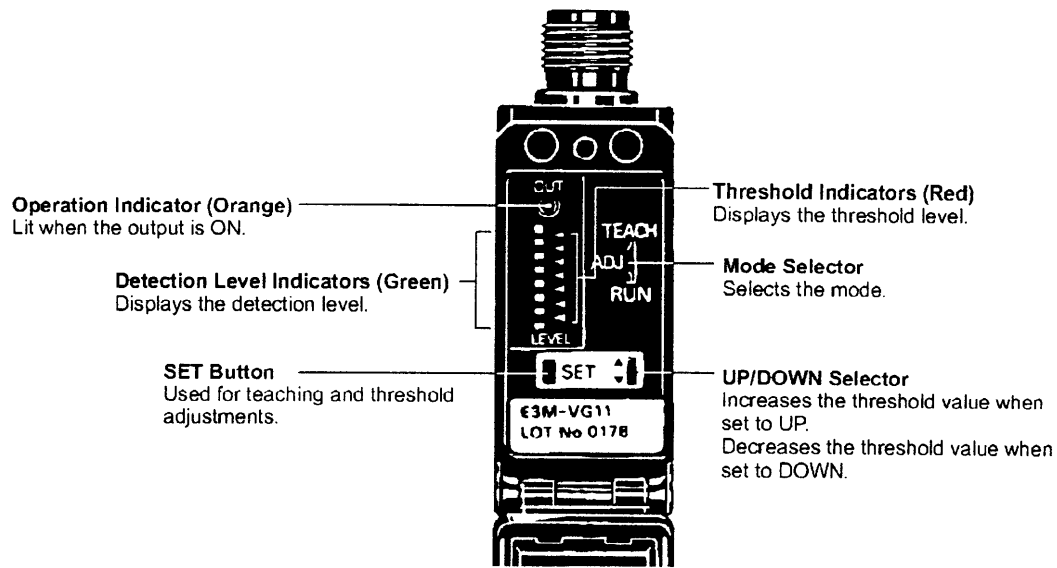

Operation

Output Circuits

NPN (E3M-VG11, E3M-VG21)

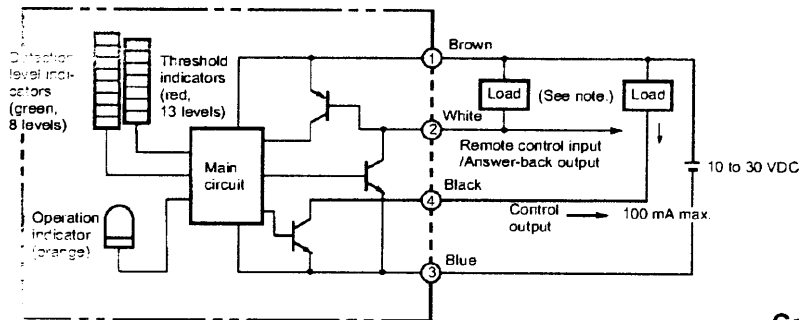

Connector Pin Arrangement



PNP (E3M-VG16, E3M-VG26)

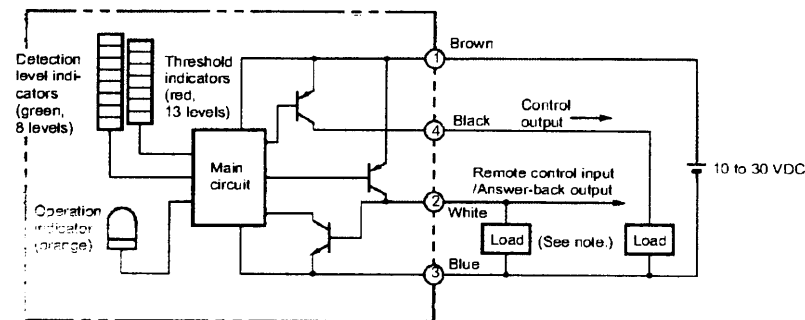

Note: Remote control input and answer-back output share the same line. Be sure to connect the load as shown above if the remote control function is used.

**Adjustments**

**Adjustment Steps**

1. Install, wire, and turn ON the Photomicrosensor.
2. Perform teaching (mark registration). Refer to *Mark Registration (Teaching)*.

3. Make fine adjustments of the threshold level if necessary. Refer to *Threshold Level Adjustments*.
4. Check that the mode selector is set to RUN.

**Mark Registration (Teaching)**

Refer to the following for ideal teaching.

Application		
The base has a color pattern. The mark and base are clearly different in color.	The base has no color pattern. The mark and base are slightly different in color.	The base has no color pattern. Remote teaching with no positioning is desired.
↓	↓	↓
One-point teaching	Two-points teaching	Auto-teaching
The default level is set and the output is ON when the mark is detected.	The threshold level is set between the color of the mark and base. The output is ON when the mark is detected.	The threshold level is set between color of the mark and base. The output is ON when the mark (i.e., the color with shorter passing time) is detected.

Refer to the following for each teaching method. Remote one- or two-point teaching is possible. Refer to *Remote Control Function*.

**One-point Teaching**

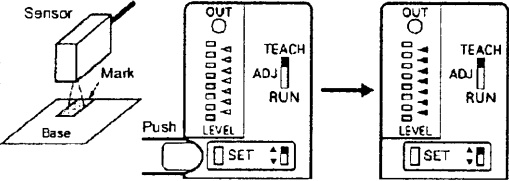
1. Set the mode selector to TEACH.
2. Locate the mark to the sensing position and press the SET button. Then all the red threshold indicators are ON.
 

Red threshold indicators are ON
3. Set the mode selector to RUN. The output will be ON whenever the set mark is detected.

**Note:** By teaching on the base, reversed output as shown above (base: ON, mark: OFF) can be obtained.

**Two-point Teaching**

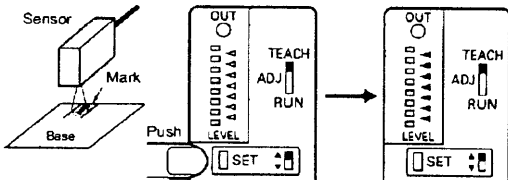
1. Set the mode selector to TEACH.
2. Locate the mark to the sensing position and press the SET button. All the red threshold indicators will turn ON.
 

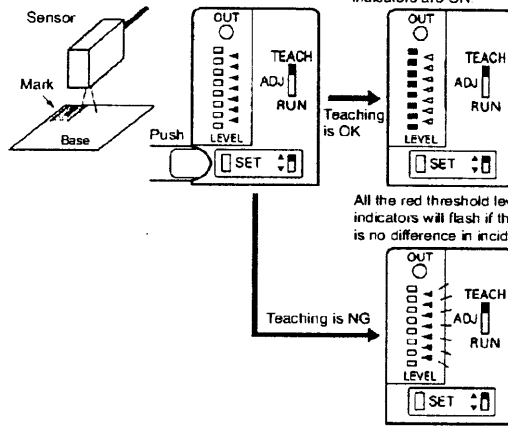
Red threshold indicators are ON
3. If teaching is successful, move the mark and press the SET button at the base.
  - If teaching is successful, all the green detection level indicators are ON.
  - If teaching is unsuccessful, all the red threshold level indicators flash.

Green detection level indicators are ON

Teaching is OK

Teaching is NG

All the red threshold level indicators will flash if there is no difference in incident.
4. If teaching is successful, set the mode selector to RUN to complete the teaching operation. If teaching is unsuccessful, restart from the above step 2.

**Note:** Follow the above steps so that the output will be turned ON whenever the mark is detected. By taking the opposite steps, the output will be turned OFF whenever the mark is detected and turned ON whenever the base is detected.

## Adjustments

### Adjustment Steps

#### Auto-teaching

1. Check that the mode selector is set to either RUN or ADJUST.
2. Input a 0.9-s pulse signal into the remote control I/O terminal. (See note.)
3. Auto-teaching starts when the mark is moved. When the mark passes six times, auto-teaching completes.
4. If teaching is successful, answer-back output from the remote control I/O terminal will turn ON for 0.3 s.
5. If teaching is unsuccessful, no answer-back signal will be output. Readjust using two-point teaching. (Teaching will be unsuccessful if there is no difference in incident between the mark and base.)
6. If the answer-back signal is ON, the whole teaching operation will be completed. The output will be turned ON whenever the mark (i.e., the color with shorter passing time) is detected.

Note: Make sure that the input tolerance of each pulse is within  $\pm 0.1$  s.

#### Auto-teaching

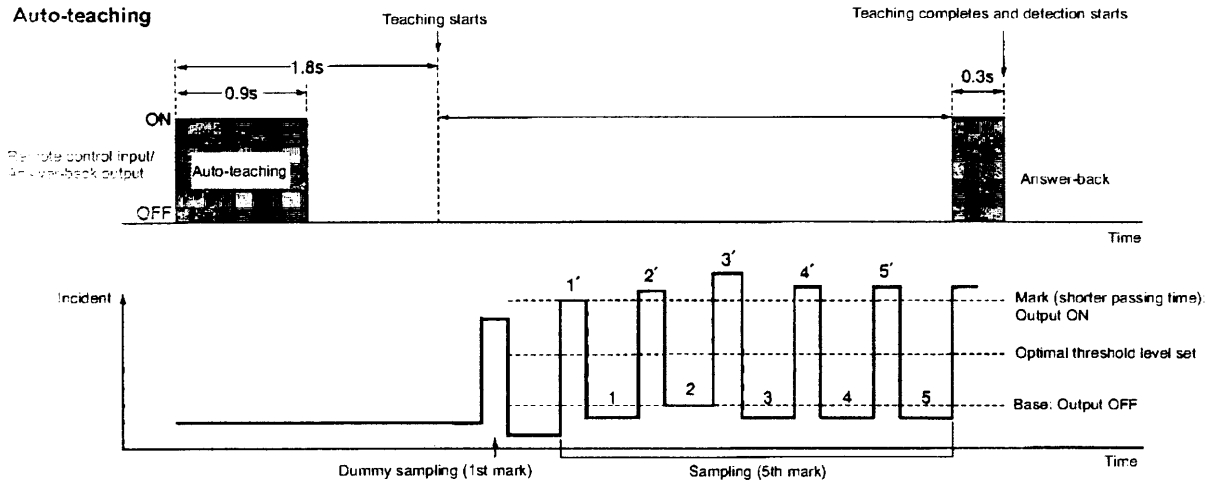

#### Example of Connection to Programmable Controller

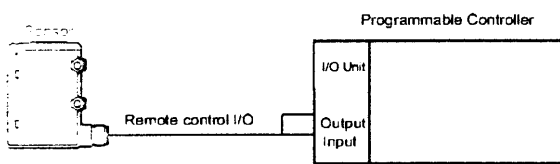

Note: Be sure to connect the E3M-V to the Programmable Controller as shown above.

#### Precautions when Using Automatic Teaching

Incorrect discrimination may be caused by automatic teaching in the following cases. Use one-point or two-point teaching in such cases.

- Color patterns exist in the base.
- Sensing objects change their positions.
- Sensing objects have protrusions or surface level differences.

#### Threshold Level Adjustments

It is possible to make fine adjustments of the threshold level after teaching. Such fine adjustments can be made remotely as well. Refer to *Remote Control Function*.

1. Set the mode selector to ADJUST.
2. Select the upper or lower threshold setting with the threshold selector. Whenever the SET button is pressed, the threshold level will move. Two indicators will be lit together when the threshold level is an even level.
 

Threshold level	1	2	3	4	5	6	7	8	9	10	11	12	13
Threshold indicators	▲▲▲▲▲	▲▲▲▲▲	▲▲▲▲▲	▲▲▲▲▲	▲▲▲▲▲	▲▲▲▲▲	▲▲▲▲▲	▲▲▲▲▲	▲▲▲▲▲	▲▲▲▲▲	▲▲▲▲▲	▲▲▲▲▲	▲▲▲▲▲
3. After setting the level, set the mode selector to RUN.

### Adjustments

#### Detection Level Indicator

The control output of the E3M-V will be turned ON if the detection level exceeds the threshold level. The indication of the detection level varies with the teaching method.

#### One-point Teaching

The upper and lower threshold values are set on the basis of the mark and the detection level indicators indicate the degree of color conformity to the mark's color.

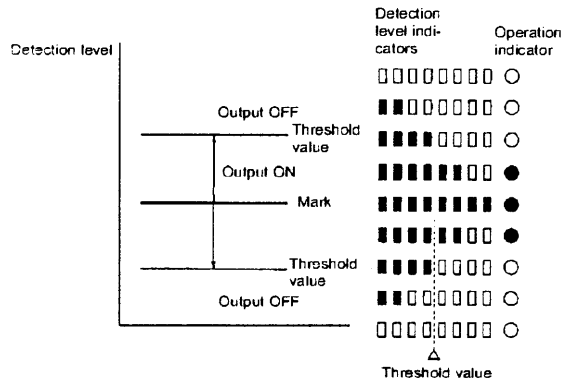

#### Two-point or Auto-teaching

A single threshold value is set between the mark (registered first) and the base (registered next). The detection level indicators indicate the tolerance between the mark and base.

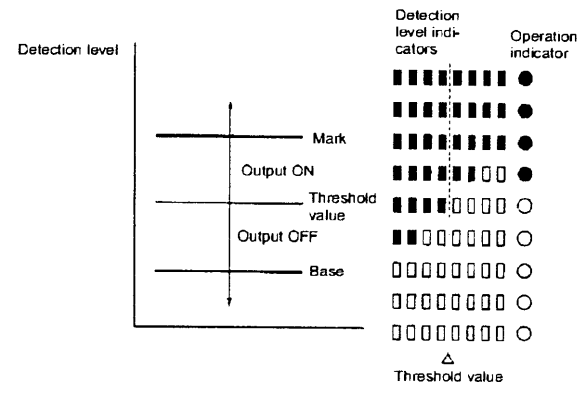

### Remote Control Function (Bank Selection, Mark Registration, and Threshold Adjustments)

#### Under Run Mode or Adjust Mode

The input of any of the signals listed in the following table into the remote control I/O terminal allows remote control of the E3M-V. When the signal is accepted, answer-back output will be turned ON for 0.3 s. Only in the case of one-point teaching, however, can the signal be manually input, provided that the input is ON for 1.5 s or more.

#### Timing Chart

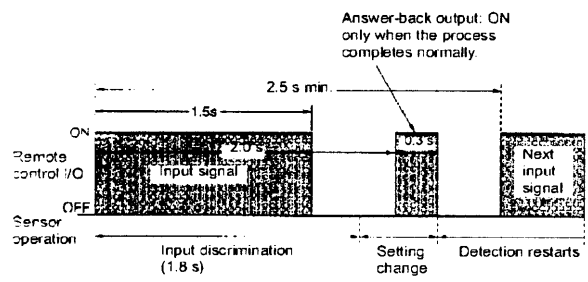

**Note:** If signals are sent continuously, make sure that there is an interval of 2.5 s between signal inputs as shown above.

#### Control Signals

No.	Control signal	Function
1	ON pulse 0.3s	Bank 1 is selected (operation indicator OFF in TEACH mode)
2	ON pulse 0.6s	Bank 2 is selected (operation indicator ON in TEACH mode)
3	ON pulse 0.9s	Auto-teaching
4	ON pulse 1.2s	Two-point teaching (1st and 2nd)
5	ON pulse 1.5s	One-point teaching (or input for 1.5 s min.)
6	ON pulse 0.3s, 0.3s, 0.3s	Threshold level 1 is selected.
7	ON pulse 0.3s, 0.6s, 0.3s	Threshold level 3 is selected.
8	ON pulse 0.3s, 0.9s, 0.3s	Threshold level 5 is selected.
9	ON pulse 0.3s, 0.3s, 0.6s	Threshold level 7 is selected.
10	ON pulse 0.3s, 0.6s, 0.6s	Threshold level 9 is selected.
11	ON pulse 0.3s, 0.3s, 0.9s	Threshold level 11 is selected.
12	ON pulse 0.6s, 0.3s, 0.3s	Threshold level 13 is selected.

**Note:** The input error of each signal pulse must be within  $\pm 0.1$  s.

**Ladder Program Example**

Control signals are input by a ladder program as shown below.

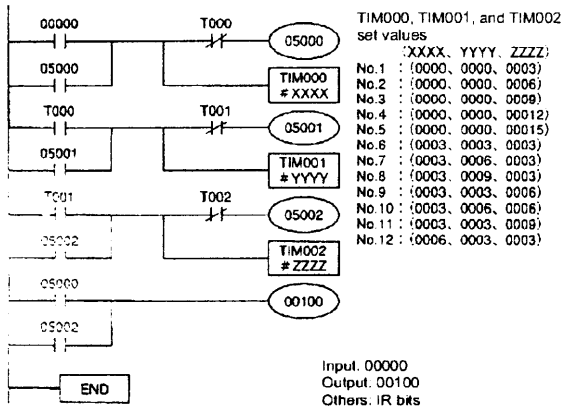

**Dimensions**

Note: All units are in millimeters unless otherwise indicated.

**Color Mark Sensors**

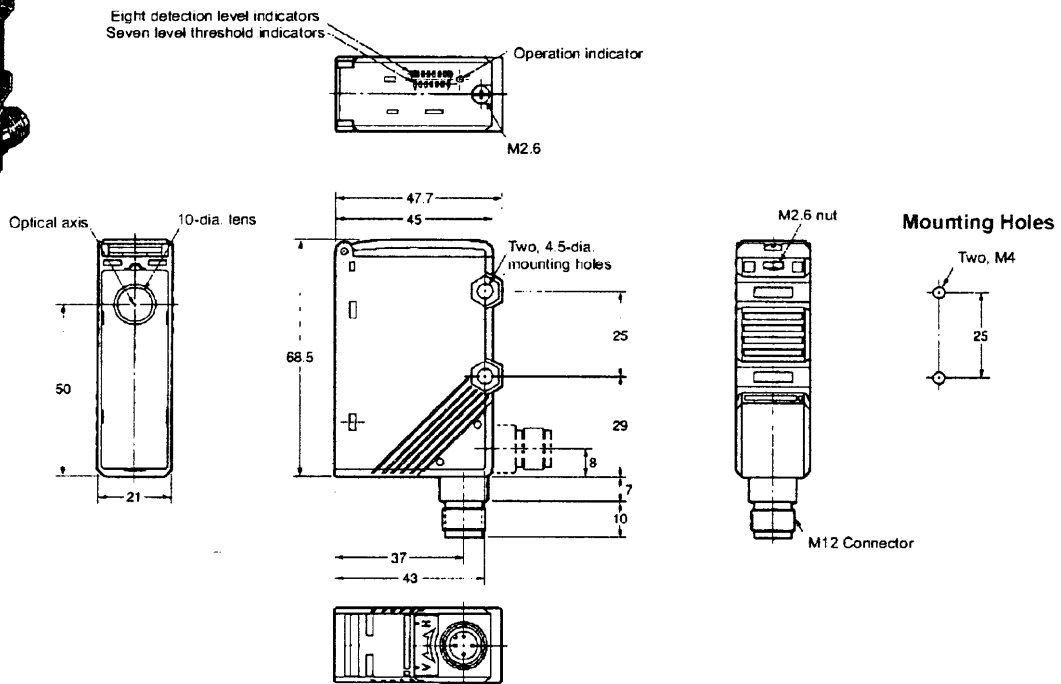
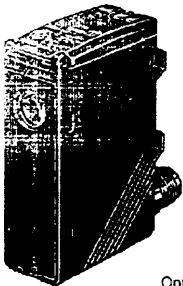



Accessories (Order Separately)  
Mounting Brackets

E39-L131

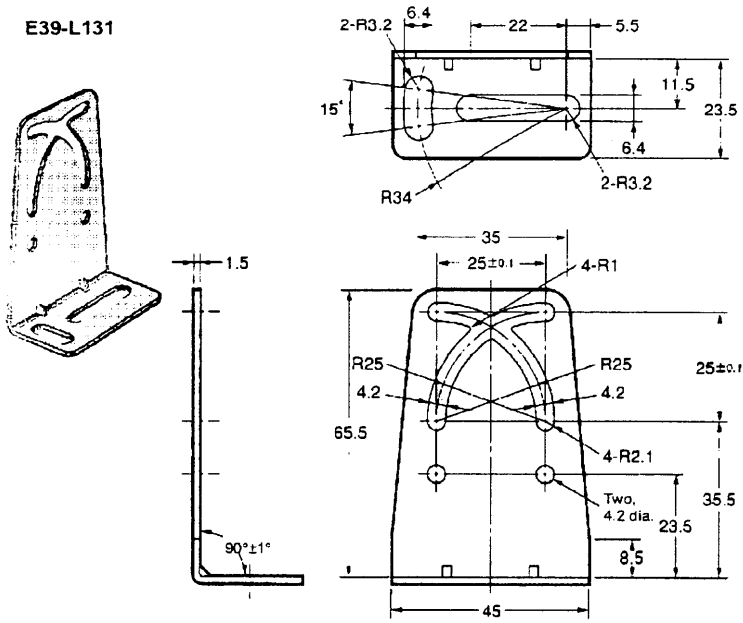

Material: Stainless steel (SUS304)

E39-L132

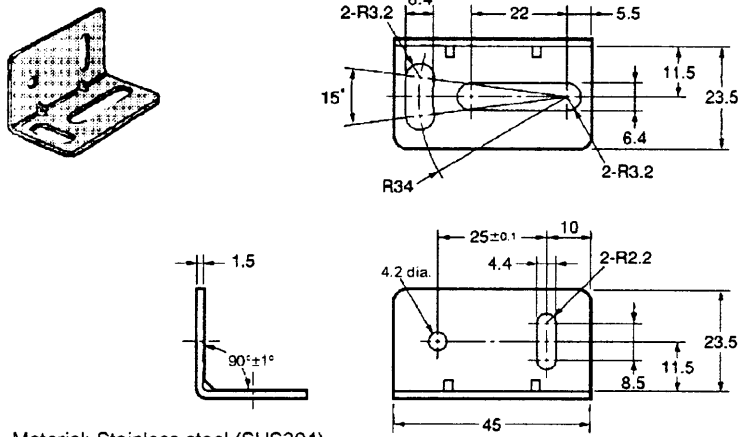

Material: Stainless steel (SUS304)

E3M-V **OMRON** E3M-V

Sensor I/O Connectors

Single-end Connector (Straight Model)

XS2F-D421-D80-A (L=2 m)  
XS2F-D421-G80-A (L=5 m)

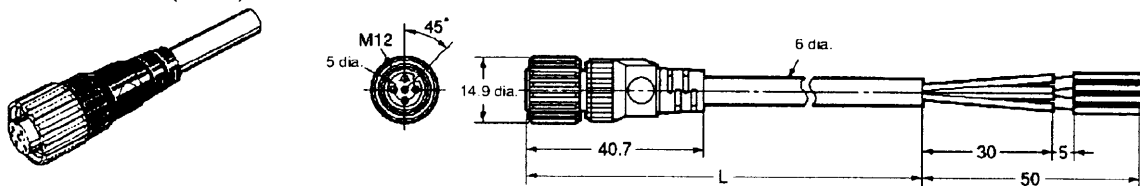

Single-end Connector (L-shaped Model)

XS2F-D422-D80-A (L=2 m)  
XS2F-D422-G80-A (L=5 m)

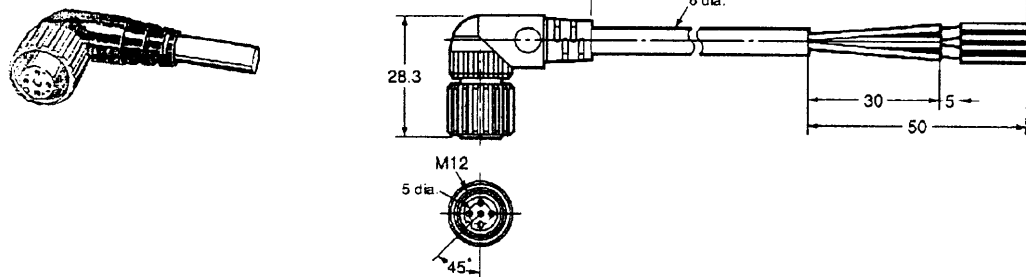

Installation

■ Sensor I/O Connector

XS2F-D421-D80-A  
XS2F-D421-G80-A  
XS2F-D422-D80-A  
XS2F-D422-G80-A

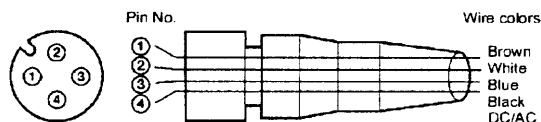

Note: For details, refer to the *Sensor I/O Connectors Catalog* (X055).

Classification	Wire color	Connector pin No.	Use
DC	Brown	1	Power supply (+V)
	White	2	Remote control input/ Answer-back output
	Blue	3	Power supply (0V)
	Black	4	Output

## Precautions

Observe the following precautions to ensure safety.

- Do not use the Sensor in locations subject to flammable or explosive gases.
- Do not use the Sensor in water or conductive solution.
- Do not disassemble, repair, or modify the Sensor.
- Use the Sensor under proper power supply specifications such as the use of AC or DC power supply.
- Do not apply any voltage or current exceeding the rated level.
- Be careful with the power supply polarities and wire correctly.
- Connect the loads correctly.
- Do not short-circuit both ends of loads.

### Correct Use

#### Installation

##### Power Reset Time

Since the E3M-V is ready to detect objects from 100 ms max. after the E3M-V is turned ON, operate the remaining devices 100 ms after the Sensor is turned ON. If power is supplied to the E3M-V and the load independently, be sure to turn on the E3M-V first.

##### Power OFF

The E3M-V may output a single pulse when the control power supply is turned OFF. If the E3M-V is connected to a timer or counter to which power is supplied from an independent power supply, the E3M-V will be more likely to output a single pulse when the control power supply is turned OFF. Therefore, supply power to the timer or counter from the same power supply for the E3M-V.

##### Power Supply Type

No full-wave or half-wave rectified power supplies can be connected to the E3M-V.

##### Power Supply Connection

Be sure to ground the FG (frame ground) and G (ground) terminals if a switching regulator is connected to the E3M-V, otherwise the E3M-V may malfunction due to the switching noise of the switching regulator.

### Wiring

#### Cable

The cable can be extended up to 100 m provided that the thickness of the cable is 0.3 mm<sup>2</sup> minimum.

#### Repeated Cable Bending

The cable must not be bent repeatedly.

#### High-tension Lines

The power supply lines of the Sensor must not be wired alongside power lines or high-tension lines in the same conduit, otherwise the Sensor may become damaged or malfunction due to induction noise that may be generated from the power lines or high-tension lines. Route the lines separately or in a single conduit.

#### Cable Pulling Force

Do not pull cables with pulling forces exceeding 50N.

### Mounting

#### Screw Tightening

Make sure that the casing is tightened to a maximum torque of 1.2 N·m.

#### Mounting Direction

When Sensors are mounted to face each other, make sure to adjust the optical axes so that the Sensors will not be mutually interfered.

### Others

#### EEPROM Write Error

An EEPROM error may result if power supply to the Sensor fails or the Sensor is influenced by static noise, in which case the threshold level indicators will flash. Perform the teaching and threshold level setting of the E3M-V again.

#### M12 Metal Connector

Make sure to connect or disconnect the metal connector after turning off the E3M-V.

Make sure to hold the connector cover when connecting or disconnecting the metal connector.

Tighten the metal connector securely by hand. Do not use any tool, such as pliers, otherwise the metal connector may be damaged.

If the metal connector is not tightened securely, the metal connector may be disconnected by vibration and the proper degree of protection of the E3M-V may not be maintained.

E3M-V

OMRON

E3M-V

**ALL DIMENSIONS SHOWN ARE IN MILLIMETERS.**

To convert millimeters into inches, multiply by 0.03937. To convert grams into ounces, multiply by 0.03527.

Cat. No. E280-E1-1A In the interest of product improvement, specifications are subject to change without notice.

**OMRON Corporation**

Industrial Automation Company

Industrial Sensors Division  
Sensing Devices and Components Division H.Q.  
28th Fl., Crystal Tower Bldg.,  
1-2-27, Shiomi  
Chuo-ku, Osaka 540-6028 Japan  
Phone: (81)6-6949-6012 Fax: (81)6-6949-6021

Printed in Japan  
0499-3M (0898) Ⓐ