

PRODUCT DATA SHEET / DATENBLATT

P/N 624 682 3 012

Crimping die set for use with the following hand tools or CM25 crimp machines
Crimpeinheit für folgende Handwerkzeuge oder CM25 Crimpmaschinen



P/N 624 000 6
P/N 624 000 3



P/N 6370 0100 1 (EU)
P/N 6370 0200 1 (GB)
P/N 6370 0300 1 (USA)



P/N 636 025-1
P/N 636 025-5
P/N 636 025-6

Description
Bezeichnung

Crimping die set 12.682 incl. locator / positioner and wire stop
Crimpeinsatz 12.682 incl. Positionierer Drahtanschlag

Image
Darstellung

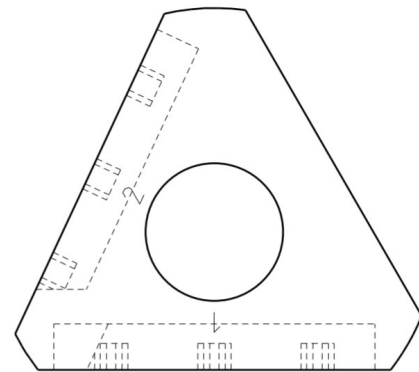
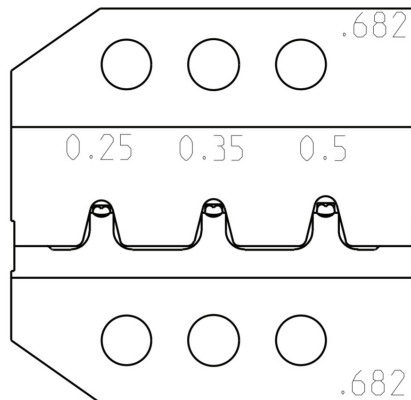

Capacity mm² or AWG
Kapazität mm² oder AWG

0,25 – 0,5 mm²
22 - 20 AWG

Application (contact P/N) Anwendung (Kontaktnummer)	Contact description	Manufacturer	P/N- Strip	P/N- Loose	Type	Range mm ²
	MQS	Tyco Electronics	-	1355988	Female	0,20 - 0,50
	MQS	Tyco Electronics	-	968220	Female	0,25 - 0,50
	MQS	Tyco Electronics	1241918	1241919	Female	0,20 - 0,50
	MQS	Tyco Electronics	928918	963725	Male	0,20 - 0,50
	MQS	Tyco Electronics	928999	963726	Female	0,20 - 0,50